

Four-dof PKM with Articulated Travelling-Plate

Pierrot F., Company O., Krut S., Nabat V.

Abstract

This paper discusses some ways to achieve large tilting motions with PKM by resorting to articulated travelling plate. Different known options are firstly presented: remote actuation, hybrid architectures, redundancy, rotation amplification, and translation-to-rotation transformation.

Starting from two of those features, the aim of this paper is to go one step further and to analyse various ways to obtain 4-dof robots which compare directly with commercially available Delta-like robots in terms of technology, workspace, and performance while avoiding the central, telescopic, RUPUR kinematic chain.

1 Introduction

The aim of this paper is to present various ways to obtain 4-dof robots which compare directly with commercially available Delta-based robots in terms of technology, workspace, and performance while avoiding the central, telescopic, RUPUR kinematic chain. For that purpose we focus on machines with so-called *articulated* travelling plates.

The idea of parallel mechanisms resorting to a non-rigid (or: *articulated*) moving platform which includes passive joints has been introduced recently and a few academic prototypes have already demonstrated the effectiveness of this principle [1] [2] implemented for Scara motions. Indeed, the 4 *dof* (degrees of freedom) of Scara motions are well adapted to pick-and-place tasks: 3 translations to carry an object from one point to another, plus one 360-degree-rotation about a given axis in world coordinates for the orientation. Robots inspired from Delta [3] architecture encountered a real commercial success achieving this task because of their high dynamics. This is due to the lightweight (actuators are fixed on the base) parallel (having closed kinematics chains) design. However, the RUPUR kinematic chain

(*R*: Revolute, *U*: Universal, *P*: Prismatic, bold letter stands for actuated joint)) that transmits the rotational motion from a revolute actuator fixed on the frame to the end-effector may become a weak point. This is particularly true for Delta with huge workspace.

Note that one key issue is to get PKM with (at least) ± 180 degrees of rotation which is quite a large value for PKM in general. Thus, before going to the core of the subject it is briefly recalled that there are indeed various ways to get large rotation angles on PKM and this show clearly that the family of machines described later is only a subset of all possibilities.

Then starting from one possibility to get large rotation angles (the H4 solution) we come up with a complete family of mechanisms based on articulated travelling plate and Translation-to-Rotation transformation (T-to-R): each member of this family has been studied and tested and each one exhibits some specific features in term of construction easiness, or modelling simplicity or practical efficiency.

2 Getting large rotation angles

It is well established that PKM suffer from different types of singularities that are often said to belong to two families:

- Serial-type (or under-mobility) when the mechanism loses one (or more) degree of freedom;
- Parallel-type (or over-mobility) when the mechanism's stiffness vanishes in one (or more) direction.

This paper will later discuss this description of singularities (even recalling that additional problems exist ...) but it is nevertheless true that the tilting angle is often limited by parallel-type singularities. So far, different solutions have been proposed to overcome that problem and getting larger tilting angle, as described in the following sub-sections.

2.1 Remote actuation

One way to get large tilting angle is to arrange one revolute joint on the travelling plate (in a "serial" way) and, to limit the moving parts masses, to place the actuation in a remote location, that is, the base. It is the option selected for most Delta robots [3], which are build with a telescopic fourth chain (with an **RUPUR** arrangement)

dedicated to the tool rotation. This principle allows the rotation range to be as large as for serial chains (indeed, the last rotation is actually arranged in a serial way) while keeping the moving masses low because the motors is still fixed on the base.

2.2 Hybrid architectures

Kinematic optimisation is always an opened option when a PKM has to be designed, and it is often feasible to select an “optimal” set of design parameters (position of actuators, length of legs, etc.) to maximise the workspace of a mechanism in terms of tilting angle range. Obviously, this optimisation process is made easier if some constraints are removed, for example if the machine is designed for tilting purpose only.

This solution leads to machines made with two sub-parts, each of them specialized in part of the task, *e.g.*:

- An X-Y serial machine can carry a Z-A-B PKM module, this module carrying the spindle and offering a larger-than-usual tilting range (Figure 2);
- One part of the machine carries the spindle, while the part is moved by another sub-part, following the robotics “left-hand/right-hand” concept. Again the PKM module may easily be optimised for large tilting angle (Figure 3).

2.3 Redundancy

The general concept of “redundancy” applied to mechanism theory can be roughly stated as follows: installing more actuators than the number of the TCP’s degrees of freedom. For serial chains, this gives, for a given position of the TCP, and infinite number of actuated joints positions. Selecting properly a set of joints position may help in avoiding singularities. This option (called “kinematic redundancy”) exists for PKM but it has been used in a very limited numbers of cases ([4] shows one example of such an arrangement). The principle is here to select among the possible joint positions, one position that is far enough from singularities.

Moreover, PKM offer the ability to create a different type of redundancy, called “actuation redundancy” that can be described as follows: for a given set of external load, an infinite number of joint force sets exist for balancing the external load. In that case, the principle is to choose among the possible set of joint forces, one set of forces which guarantees a good stiffness (see [5] for a good implementation of such a principle).

This type of redundancy has been studied in more details for PKM than the previous one (for kinematic redundancy most efforts had been dedicated to the serial case) and several prototypes have been built, giving researchers the opportunity to evaluate control schemes. Indeed, control is here the key issue since actuation redundancy leads to over-constraint mechanisms; consequently internal forces may exist, and control schemes have to cope with that. We have, for example, done such works on a 3-dof test bed called Archi (see Figure 5).



Figure 1. ABB Robotics FlexPicker with its remote actuation.



Figure 2. An hybrid machine by DS Technologies

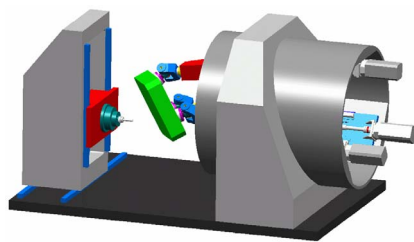

Figure 3. An example of Left-hand / Right-hand concept.



Figure 4. Speed-R-Man, a kinematically redundant PKM.



Figure 5. Archi: a 3-dof, 4-motors, actuation-redundant PKM.

2.4 Rotation amplification

In recent years, we have studied such an option in some details, by proposing different mechanisms architectures based on one key principle: designing a travelling plate which includes passive revolute joints [6]. This was the base of H4 architecture, a mechanism for “Scara-like motion”, that is XYZ translation, plus a rotation about Z axis. As shown in Figure 6, H4 is based on 4 identical elementary chains ($R[SS]_2$ chains) and a travelling plate equipped with 3 passive revolute joints. The last revolute joint is moved by a coupling system about a 360-deg range, which related its motion to the motion of another passive revolute joint that has only a 90-deg range. For example, this nacelle can be equipped with an additional gear-based amplification system leading to a large and adjustable range of motion in orientation.

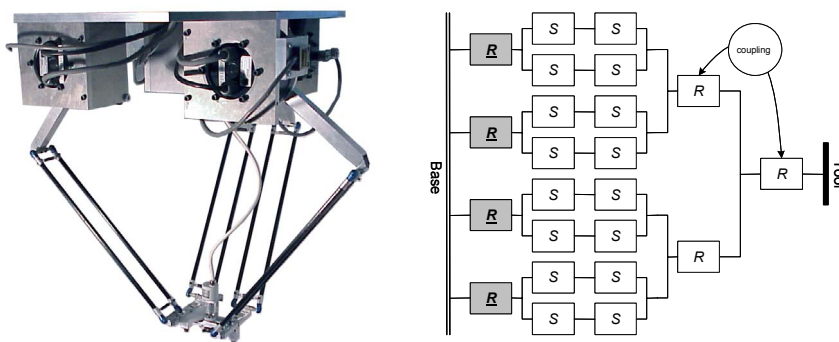

Figure 6. H4 robot: picture of actual prototype and kinematics graph showing the rotation amplification by a coupling system.

3 14: T-to-R transformation and symmetric design

However, some of limitations of H4 can be pointed out:

When the tool orientation changes, the Jacobean matrix condition number may vary a lot, leading to important changes in the machine behaviour;

Its forward geometrical model has not been established in analytical form, except for specific arrangements.

It has been proved that the relative positions of the four “spatial parallelograms” must be properly selected to avoid singular cases.

This last remark is extremely important; indeed it is possible to build H4 machines that function perfectly, but so-called *internal* singularities have to taken into account.

3.1 Singularity analysis

Singularity analysis is often based on checking the “standard” Jacobean matrices J_x and J_q representing the input-output velocity relationship:

$$J_q \dot{q} = J_x \dot{x} \quad (1)$$

where \dot{q} and \dot{x} are respectively the joint velocity vector and the operational velocity vector.

But other kind of singularities can occur [7]. To enlighten them, a deeper analysis is required. At first, we will recall the fact that “spatial parallelograms” can be seen in two different ways, and that we consider here the realistic case where spherical joints are modelled as 3-dof joints and not 2-dof joints. Then it will be shown that $(SS)_2$ chains may lead to specific singularities that are called internal singularities: taking that fact into account it is possible to create new mechanisms for which the problem is less crucial than for H4 and those mechanisms can be designed with less constraints.

According to Hervé’s notations [8] for displacements subgroups, $\{T\}$ stands for the subgroup of spatial translations and $\{X(\mathbf{u})\}$ stands for the subgroup of Schoenflies displacements (or Scara motion), where \mathbf{u} is a unitary vector collinear to the rotation’s axis. If a closed loop mechanism is composed of two chains producing Schoenflies displacements with $\mathbf{v} \neq \mathbf{u}$, then:

$$\{X(\mathbf{u})\} \cap \{X(\mathbf{v})\} = \{T\} \quad (2)$$

that is to say that such a mechanism will produce only three translations. The case of machines with $\underline{RR}(RR)2R$ chains (Figure 7-a) is easily handled with such a technique since those chains correspond to Schoenflies subgroup.

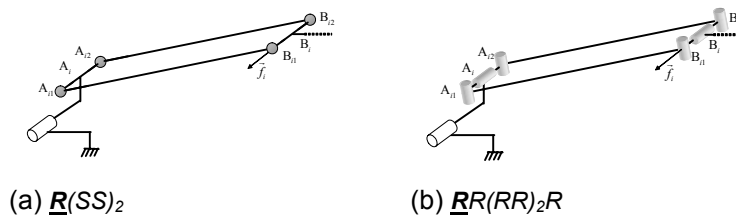
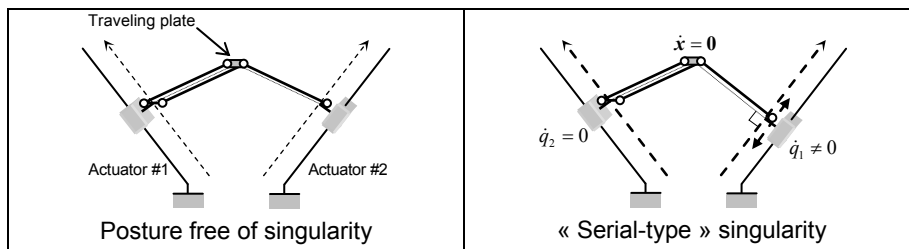

Figure 7. Two ways to model "spatial parallelograms".

The case of machines with $\underline{R}(SS)_2$ chains (Figure 7-b) is more complex: each chain provides 5 dof, 3T-2R, and does not correspond to a group. Indeed it is possible that the union (\cup) of two 3T-2R chains generates a 3T-3R motion. The following sub-sections consider precisely this type of $\underline{R}(SS)_2$ chains.

After this first preliminary remark, it has to be recalled that there are more than two types of singularities; as can be seen in Figure 8 (that shows a 2-dof, planar PKM with one \underline{PRR} chain and one $\underline{P-Par}$ chain) "serial-type" and "parallel-type" can create problems for most PKMs but other problems may exist as shown in the last drawing: here an "internal" constraint vanishes when the parallelogram (which provides the constraint "traveling plate keeps a given orientation") becomes flat. This is not specific to \underline{Par} chain but may exist for many cases but it has to be understood that for the mechanisms studied here, this is a key issue.



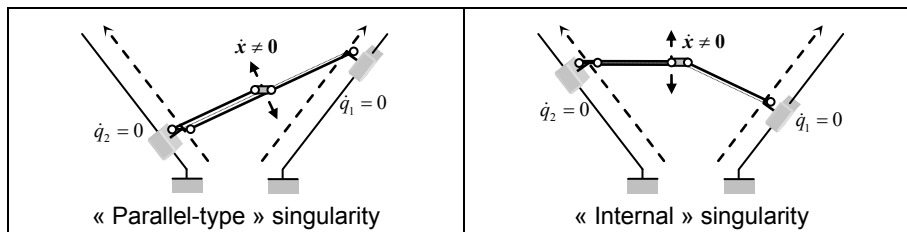

Figure 8. Serial, Parallel, and Internal Singularities

Indeed, those internal singularities are the reason that makes impossible to create an H4-based mechanism with motor axis freely chosen. As can be seen in Figure 6 one feasible design (that is: a design free of internal singularities) is to arrange two motor axis on one line and the two others on lines perpendicular to the first line. At travelling plate level, this leads to the design shown in Figure 9-a where the $(SS)_2$ chains cannot be at 90 degrees one from the other.

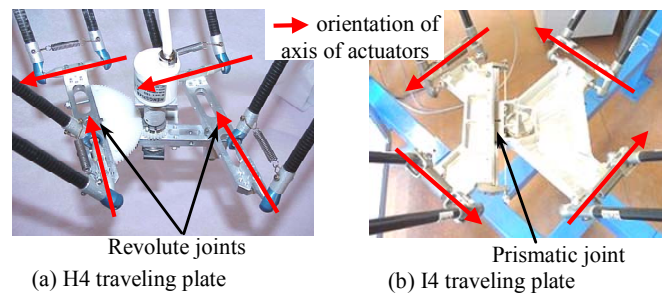

Figure 9. Relative positions of $(SS)_2$ chains for H4 and I4 mechanisms.

3.2 Option 1: I4 with a two-part nacelle

To overcome this problem we've proposed to change the travelling plate's design and to make it with two parts linked by a T joint.

The practical design is extremely simple thanks to the forearms and spatial parallelograms taken from the ABB FlexPicker (see Figure 10, left hand side).

Of course, the main difference with the ABB FlexPicker results in the use of 4 parallelograms instead of 3. Furthermore, instead of being rigid, the moving platform is articulated and does not require the kinematic chain transmitting the rotational motion to the end-effector. It is composed of two different linked together

by a prismatic guide, plus a pulley-cable system which transforms the relative translation of both parts into the desired rotation (see Figure 10, right hand side). It gives a workspace similar to FlexPicker's one – a 1-meter radius, 0.2-meter high cylinder – but overcomes the problems due to the effector's rotation. The brushless revolutes actuators are associated to gear units with very low backlash ($<1'$). Moving parts are intended to be as light as possible: forearms and parallelograms are carbon fibre parts (from ABB Robotics), while the travelling plate is made of aluminium.

This change might look as a minor change but it has indeed great consequences: First of all, the internal singularity problem vanishes (inside the practical workspace) for the arrangement seen in Figure 9-b and this allows to place motor axis at 90 degrees one from the other;

This leads to a much stiffer machine and a much better load share between motors; Moreover, both kinematic models are extremely simple and it is worth noting that both the inverse and the forward kinematic models can be derived in closed form

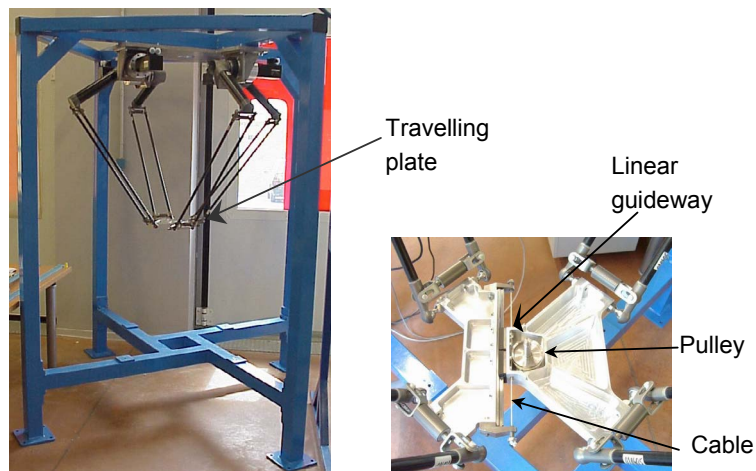

Figure 10. I4R prototype (left) and its travelling plate with a prismatic passive joint (right).

Note that the machine is over-constrained: this can be seen as an advantage on our prototype (no problem for assembly occurs; overall stiffness is higher) but can be overcome in case of need by replacing the P joint by a cylindrical joint with no change in the models.

3.3 Option 2: two-part nacelle

The I4 with two-part nacelle is an interesting machine for many reasons, including the fact that the nacelle design is straightforward and leads to a minimum weight. However, the load balance is not yet perfect; to get a perfect balance in the motor torque for a central position the weight of the carried object (work-piece, spindle, etc) has to be equally distributed among each sub-part of the traveling plate.

Figure 11 shows (right drawing) that the traveling plate can be made of three parts: the central one carries the load and is linked symmetrically to a right-part and a left-part that are exactly identical. On those right and left parts are connected the S joints. In that case the load share is really well balanced.

Moreover if this design is used with linear drives instead of revolute drives as in Figure 11 (making a *linear* I4) then the model becomes even simpler. And if all drives are parallel, it has been shown that the Jacobean matrix, for example, depends only on two parameters (Y and Z) and is independent of the rotation and the X parameter (X being aligned with the motors axis).

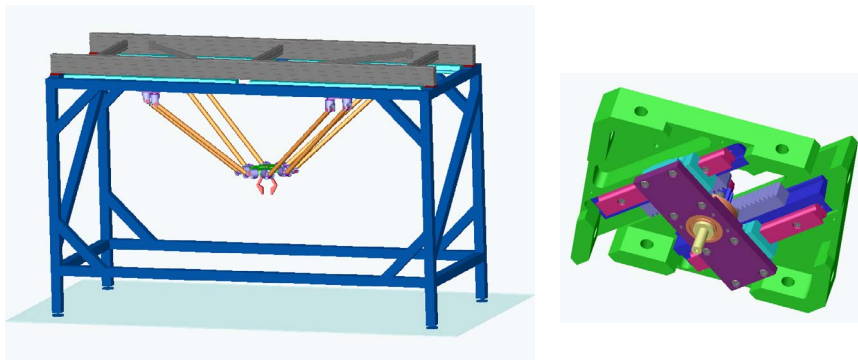

Figure 11. I4L: a prototype with T-to-R transformation and a 3-part travelling plate

Such machines are ideally designed for medium speed and large weight because they might suffer in case of very high speed combined with high acceleration: indeed the P joint on the travelling plate has to sustain heavy loads during the motions, and it is made with linear ball bearings for friction efficiency, it specifically suffers when high speeds create heavy forces on the balls: the service lifetime might be poor in extreme cases.

4 Par4

To summarize the previous cases, two options were presented:

- Traveling plate with revolute joints that creates singularity problems but can sustain very high speed (good for short cycle time but low payload);
- Traveling plate with prismatic joints that creates service lifetime problems but can sustain heavy loads (good for high payloads and larger cycle time).

There is indeed an option to get the best of both worlds: keeping only revolute joints but creating a kinematic constraint in the traveling plate that while avoid the singularity problem. This is the Par4 design: the traveling plate is composed of four parts: two main parts (1,2) linked by two bars (3,4) with revolute joints (see Figure 12). Thus, its shape is a planar parallelogram and the internal mobility of this traveling plate is a *circular translation* produced by a Par joint.

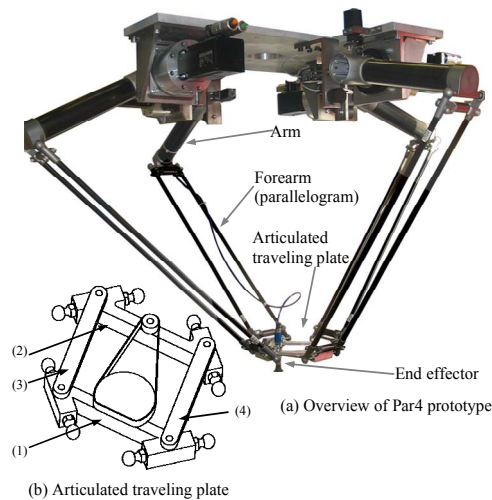

Figure 12. Par4 machine.

In addition, the “natural” range of the rotational operational motion is $[-\pi/4 ; \pi/4]$. That is why an amplification system has to be added on the travelling plate in order to make a complete turn $[-\pi ; \pi]$. Several options are available for this amplification such as gears or belt/pulleys. The prototype has been built using belt/pulleys system, with the first pulley fixed on one half travelling plate, and the second one is linked with a revolute joint to the second half travelling plate.

With that machine, Adept cycle times have been obtained lower than 0.3 second with a linear independent joint control (an evolution of PID control).

Again, this solution allows both kinematic models to be derived in closed form, and with a limited modification of the design it is possible to get a good balance of the load share on the motors.

It is worth noting that this machine is still over-constraint: other solutions can then be analyzed.

5 Heli4

In order to get a non over-constraint mechanism, an even simpler design and a more compact traveling plate we recently proposed the Heli4. As seen in Figure 13 it is possible to link the two sub-parts of the traveling plate by a helical joint.

A basic Grübler analysis can show that this mechanism is not over-constraint (away from singular positions). Using the joint-and-loop graph depicted in Figure 14 the following items can be listed:

- $p = 16$ parts
- $n = 22$ joints
- 5 R joints, 16 S joints, 1 H joint.

This statement leads to ν , the number of independent loops:

$$\nu = n - p + 1 = 7 \quad (3)$$

Additionally, the total number of dof of the mechanism is:

$$\sum \text{DoF} = \underbrace{5 \times 1}_{\substack{5 \text{ R joints} \\ \times 1 \text{ DoF}}} + \underbrace{16 \times 3}_{\substack{16 \text{ S joints} \\ \times 3 \text{ DoF}}} + \underbrace{1 \times 1}_{\substack{1 \text{ H joint} \\ \times 1 \text{ DoF}}} = 54 \quad (4)$$

Hence, the number of unknown velocities U_K , of velocity equations E_K , of unknown forces U_S , of force equation E_S , are derived:

$$U_K = \sum \text{DoF} = 54 \quad (5)$$

$$E_K = 6\nu = 42 \quad (6)$$

$$U_S = 6n - \sum \text{DoF} = 78 \quad (7)$$

$$E_S = 6(p-1) = 90 \quad (8)$$

The Grübler mobility index m is derived as follows:

$$m = U_K - E_K = E_S - U_S = 12. \quad (9)$$

As this value is shared between the “kinematic mobility” m_C and the “degree of constraint” m_S :

$$m = m_K + m_S \quad (10)$$

and since $m_K = 12$ (8 internal motions, each rod being able to rotate about its own axis, plus 4 dof for the whole mechanism) the degree of constraint m_S of the mechanism is equal to zero:

$$m_S = 0, \quad (11)$$

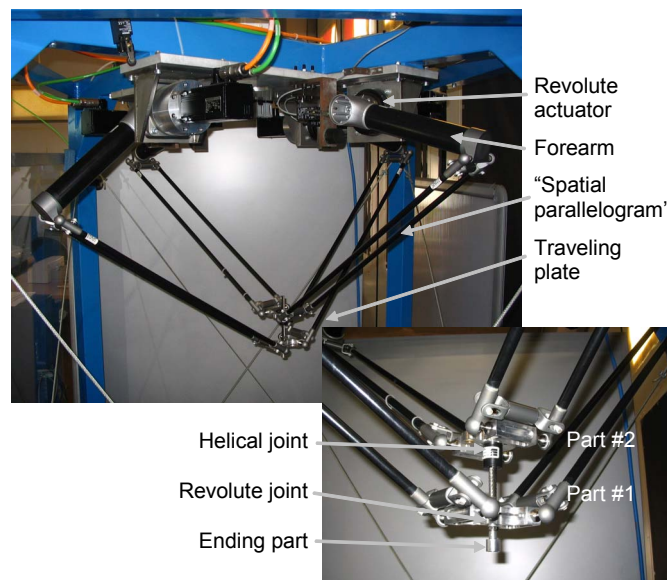

Figure 13. Heli4 prototype.

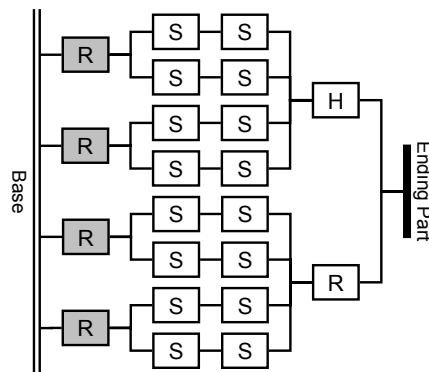

Figure 14. Heli4 joint-and-loop graph.

Heli4 is a kind of “minimal” solution and it will be intensively tested in a near future.

However with all its advantages, it might be that some applications required different features: for examples a limited footprint. Indeed, all previous machines (H4, I4, Par4, Heli4) requires quite a large area to be installed by comparison to their workspace.

6 Dual4

In case the ratio between footprint and workspace become an important criteria, it is possible to propose machines with all motors on the same (vertical) axis (thus the footprint is here minimum) while keeping the 4 necessary dof. Even more it is possible to do so and to provide an “unlimited” rotation angle in the same time.

This is the solution called Dual4 where the traveling plate is made with a single piece that is (as shown in Figure 15) guided with respect to Arm1 with a Cylindrical joint (one P and one R on the same axis). This piece is moved by Arm2 in both translation (providing the Z axis) and rotation.

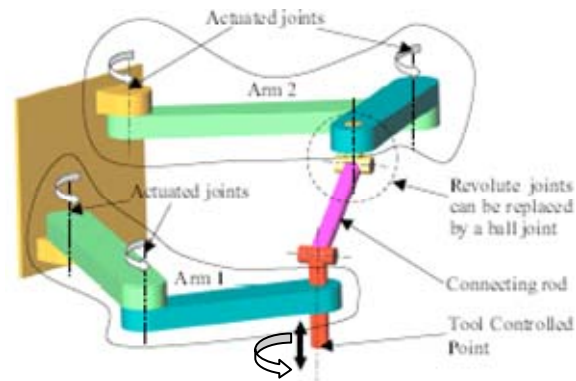

Figure 15. The functioning principle of Dual4.

This general principle can be implemented in various ways, including the one depicted in Figure 16.

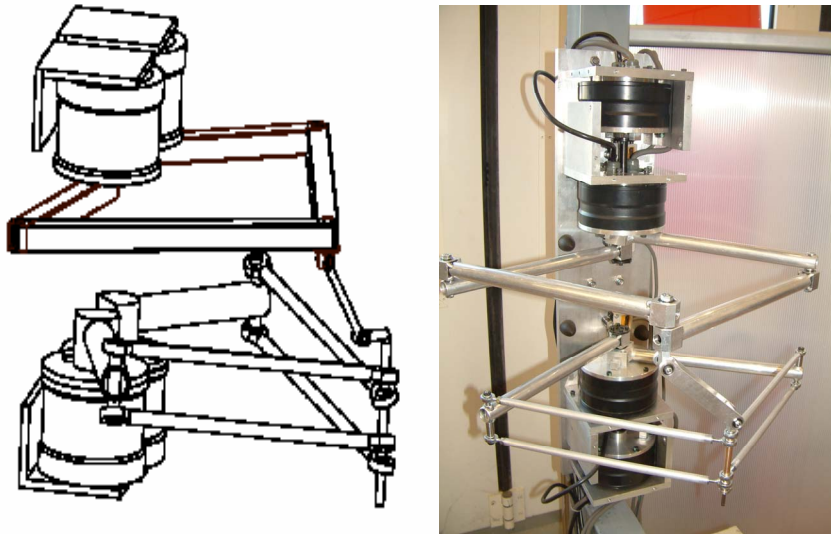

Figure 16. One possible practical design of Dual4

Of course other implementations are possible including the one in Figure 17 which has in fact several common points with one possible design of H4 (that had been called asymmetrical design of H4 in [1] [9] [10]). Interestingly enough both designs have been discovered from completely different considerations. The key advantage

of Dual 4 is that, by “reducing” the size of the travelling plate to zero, one singular posture (parallel-type) that existed with H4 (in its asymmetrical design) vanishes and a complete turn becomes possible.

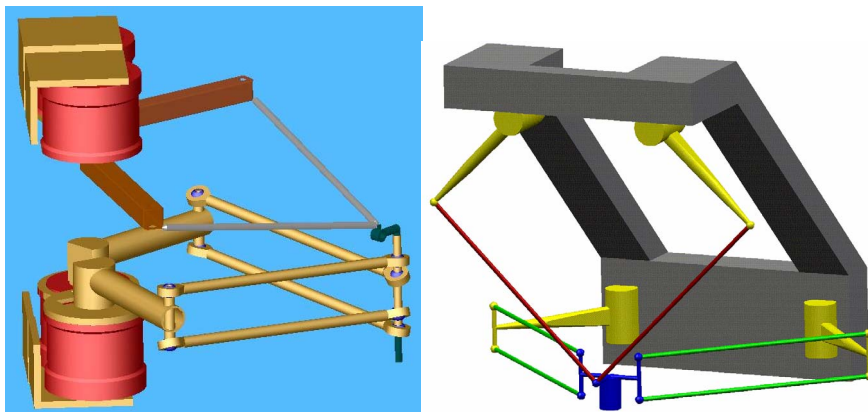

Figure 17. Another implementation of Dual4 principle and the equivalent asymmetrical H4

7 Conclusion

In this paper, several techniques for reaching high tilting angles have been presented, with a focus on solutions related to articulated travelling plates. Starting from one of such techniques a complete family of 4-dof, Scara-motion capable, parallel mechanisms have been shown and their respective key features exhibited. All solutions have been transformed into prototypes and tested: in some cases the tests have been conducted in detail and interesting performance reached (cycle time lower than 0.3 second). Most cases should now be further analysed to decide which ones could be suitable from industrial use.

It is also important to remember that other approaches are still possible to get 4-dof, Scara-motion-capable machines such as in [11] [12] for example: the “landscape” of PKM with lower mobility is definitely extremely rich.

8 References

- [1] Pierrot F., Company O., "H4: a new family of 4-dof parallel robots", in *Proc of IEEE/ASME International Conference on Advanced Intelligent Mechatronics, Atlanta, Georgia, USA, September 19-22, 1999*, pp. 508-513.
- [2] Krut S., Company O., Benoit M., Ota H. and Pierrot F., "I4: A new parallel mechanism for Scara motions", in *Proc. of IEEE ICRA: Int. Conf. on Robotics and Automation, Taipei, Taiwan, September 14-19, 2003*.
- [3] Clavel R., "Une nouvelle structure de manipulateur parallèle pour la robotique légère", *APII*, 23(6), 1985, pp. 371-386.
- [4] Marquet F., Krut S., Company O. and Pierrot F., "Archi, a redundant mechanism for machining with unlimited rotation capacities", *Proc. of ICAR 2001, Budapest, Hungary, Aug. 2001*.
- [5] Ryu S.J., Kim J.W., Hwang J.C., Park C., Ho H.S., Lee K., Lee Y., Cornel U., Park F.C. and Kim J., "ECLIPSE: An Overactuated Parallel Mechanism for Rapid Machining", *Proc. ASME Int. Mechanical Engineering Congress and Exposition, Vol. 8, USA, 1998*, pp. 681-689.
- [6] Krut S., Company O., Marquet F. and Pierrot F., "Twice: A Tilting Angle Amplification System for Parallel Robots", in *IEEE Int. Conf. on Robotics and Automation, Washington, Washington D.C., USA, May 11-15, 2002*, pp. 4108-4113.
- [7] Zlatanov D., Fenton R.G., and Benhabib B., "Identification and classification of the singular configurations of mechanisms", *Mechanism and Machine Theory*, Vol. 33, No. 6, pp. 743-760, August 1998.
- [8] Hervé J.M., "The Lie group of rigid body displacements, a fundamental tool for mechanism design", *Mechanism and Machine Theory*, Vol. 34, 1999, pp. 719-730.
- [9] Company O., Pierrot F., "A new 3T-1R parallel robot", in *Proc. of 9th International Conference on Advanced Robotics, Tokyo, Japan, October 25-27, 1999*, pp. 557-562.
- [10] Pierrot F., Marquet F., Company O., Gil T., "H4 parallel robot: modeling, design and preliminary experiments", in *Proc. of IEEE Int. Conf. On Robotics and Automation, Seoul, Korea, May 2001*.
- [11] Rolland L., "The Manta and the Kanuk: Novel 4 dof parallel mechanism for industrial handling", in *Proc. of ASME Dynamic Systems and Control Division IMECE'99 Conference, Nashville, November 14-19, 1999*, vol. 67, pp 831-844.
- [12] Angeles J., Morozov A., Navarro O., "A novel manipulator architecture for the production of SCARA motions", in *Proc. IEEE International Conference on Robotics and Automation, San Francisco, April 24-28, 2000*, pp. 2370-2375.