

A New Configuration of Multipolar Cuff Electrode and Dedicated IC for Afferent Signal Recording

Lionel Gouyet, Guy Cathébras, Serge Bernard, David Guiraud and Yves Bertrand

Abstract—Sensory information coming from natural sensors and being propagated on afferent nerve fibers could be used as feedback for a more efficient closed-loop control of a Functional Electrical Stimulation system. In order to extract and separate these signals according to their nerve fascicule origins, we propose a new architecture of a multipolar cuff electrode and an optimized integrated acquisition circuit. Concerning the electrode, we propose a specific configuration using a large number of poles in order to both reject parasitic signals, such as electromyogram and provide a maximum of recording channels in order to help the signal localization inside the nerve. Moreover, specific low-level analog signal processing was designed to extract the expected low-amplitude signal from its noisy environment. This signal processing is implemented in an ASIC that has to be implanted close to the electrode to achieve the best signal-to-noise ratio.

I. INTRODUCTION

Functional Electrical Stimulation (FES) techniques are one possible alternative to restore lost sensory or motor abilities due to neural system pathologies such as spinal cord injury. It consists of replacing the natural direct muscle activation by electrical stimulation which can evoke an artificial contraction. FES can be performed using surface electrodes but implanted FES is the only solution for daily use context outside a clinical environment [1].

An efficient way to perform closed-loop control using implanted FES is to take advantage of the remaining natural sensors. To do so, the main challenge is the recording and the processing of afferent neural signals to provide data such as the length of the muscles, the force they generate, skin contact or the pain that could be evoked. FES systems could then be designed as to achieve a closed-loop control using such signals for feedback [2].

Nerves are composed of many fibers distributed into subsets called fascicules [3]. In each fiber, the information is coded by the Action Potential (AP) that propagates along efferent axons from the Central Nervous System (CNS) to muscles or organs or along afferent axons from natural sensors to the CNS. When recorded at the nerve level, the signal translating the neural activity is called the electroneurogram (ENG). Despite its very low amplitude (typically 1-5 μV in the 1 Hz-3 kHz band [4]), it is an image of the whole nerve activity. Moreover, the ENG measurement environment

is very noisy. One of the main noise sources comes from the nearby muscular activity, electromyogram (EMG), which has signal amplitude about three orders of magnitude higher (about 1 mV).

For the moment, the better device for ENG acquisition is the tripole cuff electrode. It allows for a good signal to noise ratio and a good rejection of EMG signals. Unfortunately, this recording is particularly lacking in selectivity. To overcome this limitation, multipolar cuff electrodes were proposed. In [5], [6], a nine rings cuff electrode was used to selectively record AP effects based on their propagation speed. In [7], the central ring of the tripolar cuff electrode was broken into four contacts to improve spatial selectivity. As an alternative, longitudinal intra fascicular electrodes (LIFE) were used to get very spatially selective recordings [2], but with less stability than cuffs over extended periods.

In this paper, we consider a new configuration of the cuff electrode with a large number of poles laid-out in an hexagonal tessellation. In this configuration, a group of seven poles can behave, with suitable signal processing, like a kind of a directive antenna. Moreover, the large number of poles will allow enough channels in order to apply source separation signal processing on the ENG. Of course, the directivity of the sensor relies on the quality of the subsequent low-level analog signal processing.

Section II gives the architecture of the proposed multipolar cuff electrode. In section III, we present the design of an integrated circuit for signal amplification and low level analog signal processing. Finally, section IV gives some concluding remarks.

II. CHOICE OF THE ELECTRODE

Cuff electrodes have been the most used in a large set of experiments for the last ten years [4], [8], [9]. They are relatively easy to implant, they are not invasive for the nerve and implantation is very stable and thus allows chronic experiments.

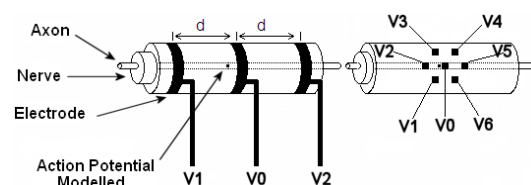

Fig. 1. Tripolar cuff and hexagonal electrode models

Manuscript received February 16, 2007. This work was supported in part by a grant common to CNRS, INRIA and INSERM and by a grant from the French Research Ministry

All authors are with the Laboratoire d'Informatique, Robotique et Microélectronique de Montpellier, Univ. Montpellier 2, CNRS, INRIA ; 161 rue Ada, 34392 Montpellier, France.

Email: Firstname.Lastname@lirmm.fr

A. Configurations for recording

ENG can be recorded as the potential difference created on the electrodes by the charges associated to the action potentials propagating along the nerve fibers. Left part of Fig. 1 shows a tripolar cuff electrode and its disposition around the nerve. When recording with this kind of electrode, a classic method to reject parasitical signals consists of calculating the average of the potential differences between the central pole and each of the outer poles [10], [11]:

$$V_{rec} = \frac{(V_0 - V_1) + (V_0 - V_2)}{2} = V_0 - \frac{V_1 + V_2}{2} \quad (1)$$

The potential created by a given charge in some point of space is inversely proportional to the distance between the charge and this point. Furthermore, we can roughly estimate the potential of a conductive ring by the mean (integral) of the potential at each point of the ring. Using these simple relationships we can study the sensitivity of the tripolar cuff electrode to a charge placed inside or around it. Let us choose a tripolar cuff whose diameter of rings is one length-unit, while the spacing of the rings (See Fig. 1) is $d = 2$ length-units. Fig. 2-left shows the variation of V_{rec} (in fact, a quantity homogeneous to the inverse of a length) as a function of charge position along the axis of the electrode (zero corresponds to the median ring).

We can see on this curve that the sensitivity of the electrode is maximum for a charge placed inside the central ring, but also that a significant effect is obtained when the charge is placed inside one of the outer rings.

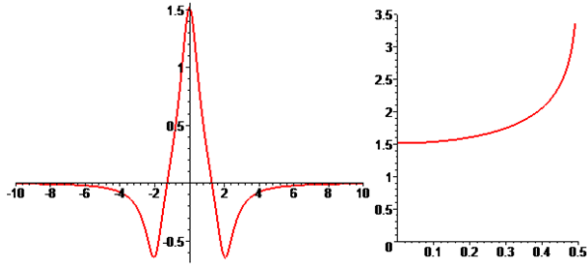

Fig. 2. Longitudinal and radial sensitivities of a tripolar cuff electrode

The curve on the right of the figure shows how this sensitivity varies when the charge is at the central ring, but not on the axis. We can see there an increase in sensitivity for the axons located at the periphery of the nerve. This effect is increased when the cuff diameter increases.

To investigate a bit more the behavior of the tripolar cuff electrode, let us see now what happens with a charge outside the electrode. The surface of Fig. 3 represents the evolution of V_{rec} when it is created on the electrode by a charge located at 10 length-units of the electrode center point, as a function of the direction. The x-axis is aligned with the electrode axis. The tripolar configuration is generally recommended to increase the EMG rejection. We can see in this figure that this rejection is large, but not infinite. Directional sensitivity remains at levels such that individual action potentials will be drowned into the EMG noise.

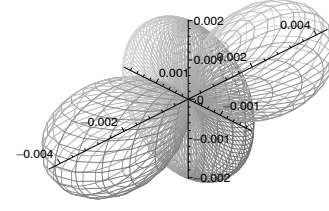

Fig. 3. Tripolar cuff electrode external sensitivity

With the aim of obtaining more localized measures, we propose to use a structure with six poles in an hexagonal configuration around a central pole (right part of Fig. 1). Let us now calculate the mean of the potential differences between the central pole and each of the peripheral poles:

$$V_{rec} = \frac{1}{6} \sum_{i=1}^6 (V_0 - V_i) = V_0 - \sum_{i=1}^6 \frac{V_i}{6} \quad (2)$$

The left part of Fig. 4 plots the evolution of V_{rec} as a function of the direction for a charge located 2.5 times the distance between two poles from the center of the hexagon. On the right part of the figure, we have plotted in dB the evolution of V_{rec} on the normal axis and on the plane of the electrode as functions of the relative distance of the charge (the unit-length is the distance between two poles of the electrode). From this result, we can conclude that this kind of electrode can get very localized information while strongly rejecting common mode noise like EMG.

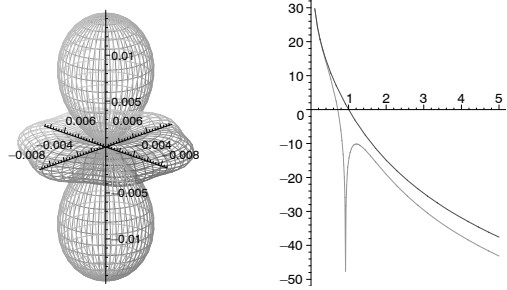

Fig. 4. Hexagonal electrode sensitivity

B. Isolation of the required afferent signal

To facilitate the signal post-processing on the recording system, we need a maximum of neural data. A tripolar electrode cuff [12] provides only one recording which is the superposition of all action potentials “seen” by the electrode at a given moment. The use of several hexagonal structures such as that presented above on a cuff electrode (see Fig. 5) could allow us to record more signals and thus increase the quantity of neural data.

Furthermore, references [6], [13] show that it is possible to extract the direction and the speed of the signal propagation of AP by using several successive poles. This principle is still relevant for our electrode and would thus allow us to obtain more accurate pieces of information about the direction and the speed of AP propagations.

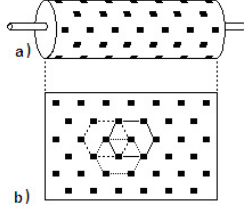

Fig. 5. Multipolar cuff electrode with hexagonal distribution

III. ENG AMPLIFIER

For one channel to be recorded, we need to consider seven recording sites. The recording system is designed both to amplify the ENG signal on a measurement point and to average the signal on the six closest surrounding points. The idea is to perform the average at lowest level to achieve the best Signal-to-Noise Ratio (SNR). We propose thus to have analog signal processing closed to the electrode.

Currently, this ENG amplifier is composed of several amplification channels, one per measurement pole in the electrode. Each channel consists of one low-noise weighted differential preamplifier and one instrumentation amplifier.

A. Preamplifier

The role of the preamplifier is to provide both an amplified signal with a high SNR, and a weighted difference between the measurement point and the six closest surrounding points as explained before. To implement these functions with classical structures using opamps and resistors, while keeping the input impedance infinite, we need at least eight opamps per channel, which is unacceptable in terms of area and consumption. Fortunately, full custom design allows us to do this with a structure using less than 20 transistors as shown on Fig. 6. This preamplifier is build around a differential pair whose negative input transistor was split into six transistors (six times smaller, of course). To improve the noise performances, we chose to use P type transistors.

Using the small-signal low-frequency model of the transistors, it can easily be shown that

$$V_{out1} - V_{out2} = \frac{gm_p}{gm_n} \sum_{i=1}^6 (V_0 - V_i) \quad (3)$$

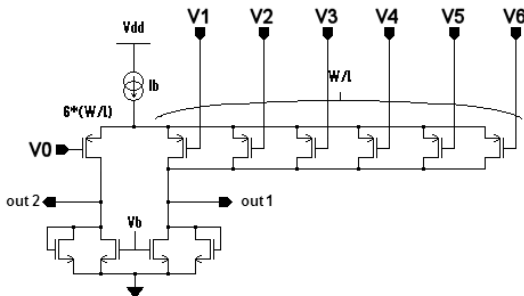

Fig. 6. Seven input preamplifier

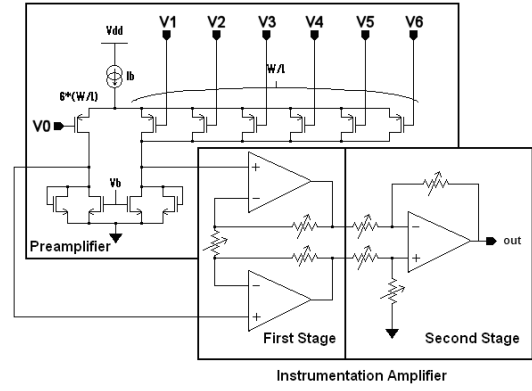

Fig. 7. One full amplification channel

where gm_p represents the transconductance of the P-MOS transistors connected to the inputs V_1 to V_6 while gm_n represents the transconductance of the diode connected N-MOS transistors at the bottom of the schematic. These diode connected transistors in parallel with the active load act as clamps in order to stabilise common mode output voltage. This solution generates much less noise than with a classic common mode feedback (CMFB) that requires several transistors. The expected voltage gain is about 100.

B. Instrumentation amplifier

Of course, a 40dB gain will not be enough to be able measure ENG signals with such a small electrode. Therefore, we added an instrumentation amplifier with programmable gain to adjust the total gain according to the amplitude of the recorded signals. The SNR optimization of the second stage is less critical because the preamplifier output provides a signal larger enough in regards to the noise generated at the entry of the second stage. In this context, standard cell opamps are used to build the instrumentation amplifier.

The programmable gains are configured numerically through analog switches and resistors. The available gains are 2, 10 and 100 for the first stage and 1, 10 and 100 for the second stage. As a result, we are able to fix the gain of the instrumentation amplifier between 2 and 10 000, i.e a gain between 6 dB and 80 dB.

C. The full amplifier

Each channel is composed of one preamplifier followed by an instrumentation amplifier as illustrated Fig. 7. The number of channels depends on the number of poles of the electrode. Because the boundary poles of the electrode could not be used as measurement point, for an n -poles electrode we need J channel with $J < n$. As an example, for seven channels, the number of poles of the electrode is $19 \leq n \leq 49$. For the ASIC we have designed, our choice was the minimization of the number of pads, so the connections are made internally to accommodate a fully connected 19-pole electrode.

This circuit was designed to give an input-referred noise below $1 \mu V_{rms}$, a CMMR above 60 dB and a sufficient gain, i.e greater than 60 dB ; all these parameters in the bandwidth of interest ($1 \text{ Hz} \leq f \leq 3 \text{ kHz}$). We have performed a large

TABLE I
AMPLIFIER CHARACTERISTICS (SIMULATION)

Active area (7 channels)	1.16 mm ²
Supply voltage	3.3 V
DC Current (Preamp)	20 μ A
Voltage gain (Preamp)	100 (40 dB)
CMRR (Preamp)	80 dB (10 kHz)
Voltage gain (Inst amp)	$2 \leq G \leq 10\,000$
CMRR (Full amp)	80 dB (10 kHz)
Input-ref. noise (Preamp)	0.672 μ V RMS
Input-ref. noise (Full amp)	0.677 μ V RMS
Bandwidth (Full amp)	76 kHz

set of simulations on the final circuit. Using Monte Carlo analysis we could estimate the expected performances of the circuit after manufacturing. The results are given in Table I (the noise is measured in the band 1 Hz-3 kHz).

The results are coherent with the required specifications since the gain is $46\text{ dB} \leq G \leq 120\text{ dB}$, the bandwidth is large enough (above 3 kHz), and the noise is below a microvolt in this bandwidth. A microphotography of the fabricated circuit is presented Fig. 8. This circuit was designed in CMOS AMS 0.35- μ m technology. It came back from manufacturing a few days ago and hardware experiments will start soon.

IV. CONCLUSION AND PERSPECTIVES

We have presented here the prototype of an implantable recording system suitable for detection of afferent information inside a nerve. The paper focused on the two first stages of this system: the electrode and the measurement integrated circuit.

Concerning the electrode, a new architecture of multipole cuff electrode has been presented. It has been shown that this hexagonal electrode allows to get very localized information while rejecting interference signals such as EMG.

A low-noise integrated circuit has been designed in order to perform a first step of analog processing on each set of seven considered poles. The first simulation results have

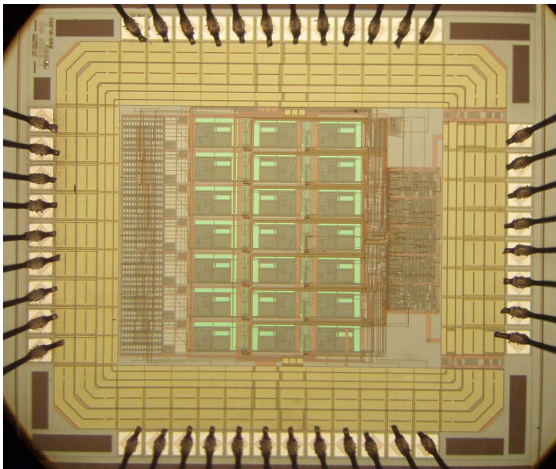

Fig. 8. Microphotograph of the seven-channel prototype

showed very good specifications of the circuit in terms of noise, bandwidth, gain and common mode rejection.

REFERENCES

- [1] D. Guiraud, T. Stieglitz, K. P. Koch, J.-L. Divoux, and P. Rabischong, "An implantable neuroprosthesis for standing and walking in paraplegia: 5-year patient follow-up," *Journal of Neural Engineering*, vol. 3, no. 4, pp. 268–275, 2006. [Online]. Available: <http://stacks.iop.org/1741-2552/3/268>
- [2] M. Djilas, C. Azevedo Coste, K. Yoshida, and G. Cathébras, "Interpretation of ENG signal for FES closed-loop control," in *IFESS'06: 11th Annual Conference of the International Functional Electrical Stimulation Society*, Miyagi-Zao, Japan, 12-15 Sept. 2006, pp. 85–87.
- [3] E. N. Marieb and K. Hoehn, *Human Anatomy and Physiology*, 7th ed. Benjamin Cummings, 2006.
- [4] M. K. Haugland, J. A. Hoffer, and T. Sinkjaer, "Skin contact force information in sensory nerve signals recorded by implanted cuff electrodes," *IEEE Transactions on Rehabilitation Engineering*, vol. 2, no. 1, pp. 18–28, 1994. [Online]. Available: <http://dx.doi.org/10.1109/86.296346>
- [5] J. Winter, M. Rahal, N. Taylor, N. Donaldson, and J. Struijk, "Improved spatial filtering of ENG signals using a multielectrode nerve cuff," in *5th Annual Conference of the International Functional Electrical Stimulation Society*, Aalborg, Denmark, June 2000. [Online]. Available: <http://www.ifess.org/ifess00/Poster%20Session%204/Winter.pdf>
- [6] J. Taylor, N. Donaldson, and J. Winter, "Multiple-electrode nerve cuffs for low-velocity and velocity-selective neural recording," *Medical and Biological Engineering and Computing*, vol. 42, no. 5, pp. 634–643, Sept. 2004.
- [7] A. Ramachandran, J. Sacristan, N. Lago, T. Dörge, M. Osès, K. Koch, and K. Hoffmann, "Multipolar cuff electrodes with integrated pre-amplifier & filter to interface peripheral nerves for FES application," in *10th Annual Conference of the International FES Society*, Montreal, Canada, July 2005. [Online]. Available: <http://ifess.org/ifess05/Poster%20Session%201/Ramachandran%20A.pdf>
- [8] W. Jensen, T. Sinkjaer, and F. Sepulveda, "Improving signal reliability for on-line joint angle estimation from nerve cuff recordings of muscle afferents," *IEEE Transactions on Neural Systems and Rehabilitation Engineering*, vol. 10, no. 3, pp. 133–139, Sept. 2002.
- [9] L. N. S. Andreasen and J. J. Struijk, "Signal strength versus cuff length in nerve cuff electrode recordings," *IEEE Trans. Biomed. Eng.*, vol. 49, no. 9, pp. 1045–1050, Sept. 2002.
- [10] J. J. Struijk and M. Thomsen, "Tripolar nerve cuff recording: stimulus artifact, EMG and the recorded nerve signal," in *Engineering in Medicine and Biology Society, 1995. IEEE 17th Annual Conference*, vol. 2, Montreal, Que., Sept. 20–23, 1995, pp. 1105–1106.
- [11] C. Pflaum, R. R. Riso, and G. Wiesspeiner, "Performance of alternative amplifier configurations for tripolar nerve cuff recorded ENG," in *Engineering in Medicine and Biology Society, 1996. Bridging Disciplines for Biomedicine. Proceedings of the 18th Annual International Conference of the IEEE*, vol. 1, Amsterdam, Oct. 31–Nov. 3, 1996, pp. 375–376.
- [12] A. Demosthenous and I. F. Triantis, "An adaptive ENG amplifier for tripolar cuff electrodes," *IEEE J. Solid-State Circuits*, vol. 40, no. 2, pp. 412–421, Feb. 2005.
- [13] R. Rieger, M. Schuettler, D. Pal, C. Clarke, P. Langlois, J. Taylor, and N. Donaldson, "Very low-noise ENG amplifier system using CMOS technology," *IEEE Transactions on Neural Systems and Rehabilitation Engineering*, vol. 14, no. 4, pp. 427–437, Dec. 2006.