

Statically Equivalent Serial Chains for Modeling the Center of Mass of Humanoid Robots

Sebastien Cotton¹, Andrew Murray², Philippe Fraisse¹

¹ LIRMM Laboratory, University of Montpellier 2, France, cotton@lirmm.fr, fraisse@lirmm.fr

² University of Dayton, Ohio, USA, Murray@udayton.edu

Abstract— This paper proposes a method for modeling the Center of Mass (CoM) of humanoid robots. The method is based on the Statically Equivalent Serial Chain (SESC) model, a serial chain representation of any multi-link branched chain. An algorithm is presented to automatically construct the SESC of a symmetric anthropomorphic architecture. We also show the use of SESC modeling in the projection of the CoM when the kinematic chain is not positioned on a horizontal plane. Finally, after validating these developments on the HOAP-3 experimental humanoid robot platform, we discuss the interest of this modeling in other areas of research.

I. INTRODUCTION

The study and management of the static balance of humanoid robots has generated significant interest in the scientific community. Of particular interest here, Espiau [1] illustrated a new way to write the Center of Mass (CoM) of a given architecture.

Following Espiau's work, we review the Statically Equivalent Serial Chain (SESC) modeling process on a basic example. This principle, applied to humanoid robots, allows us to obtain a serial-chain-like model to locate the CoM of a humanoid robot.

However, finding the statically equivalent serial chain requires a specific calculation for each architecture, a lengthy process if there are many degrees of freedom and, hence, many links. Thus, we present an efficient method and an algorithm to construct and compute the SESC automatically for a humanoid architecture using only the mechanical parameters of the studied architecture as inputs.

With the goal of managing the static balance of humanoid robots, this modeling is extended to the CoM projection. The utility of SESC modeling is displayed by including a consideration of the ground slope in the modeling.

The experimental results to validate this approach are then implemented on a HOAP-3 humanoid robot. Finally, we discuss the use of this modeling in further research including CoM workspace optimization and identification of unknown mechanical parameters on a given architecture.

II. STATICALLY EQUIVALENT SERIAL CHAIN MODELING

Classically, the center of mass (CoM) of a multi-body system is defined as the weighted average of the locations of each individual body's CoM. A new formulation for the CoM was introduced in [1] and used on a humanoid robot in a planar case in [2]. Our previous work [3], has shown a simplified approach to this modeling in the planar case and its use on a humanoid robot [4]. Of course, the knowledge of the

CoM location in two dimensional space is not sufficient to preserve the static balance of an anthropomorphic structure. Thus, we present the extension to three dimensional space of this simplified modeling, called Statically Equivalent Serial Chain Modeling.

A. Working Hypothesis

The system studied below is composed of rigid bodies, called links, connected by revolute joints. As such, each link is considered as fully described by its mass and geometric properties. Thus, for each link, the mass and the location of the center of mass are known, as are the locations of all revolute joints. The following equations use homogeneous transform matrices and link's CoM location, as described below.

$$T_i = \begin{bmatrix} A_i & \vec{d}_i \\ 0 & 1 \end{bmatrix} \quad A_i = \begin{bmatrix} A_{ixx} & A_{ixy} & A_{ixz} \\ A_{iyx} & A_{iyy} & A_{iyz} \\ A_{izx} & A_{izy} & A_{izz} \end{bmatrix} \quad \vec{d}_i = \begin{bmatrix} d_{ix} \\ d_{iy} \\ d_{iz} \end{bmatrix} \quad \vec{c}_i = \begin{bmatrix} c_{ix} \\ c_{iy} \\ c_{iz} \end{bmatrix}$$

B. SESC Modeling

Consider the branched chain shown in Fig. 1. The chain is composed of four links joined by revolute joints. Each body is described by the three parameters l_i (body length), m_i (body mass), and \vec{c}_i (location of the CoM). The total mass of the system is $M = m_1 + m_2 + m_3 + m_4$.

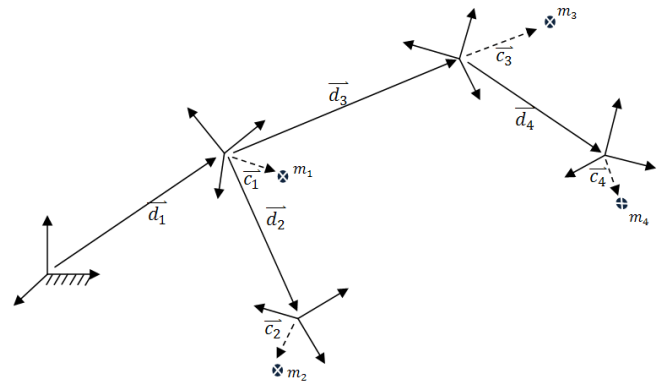

Fig. 1 Spatial branched chain and its mechanical parameters

The CoM of the entire chain is the sum of each body's CoM divided by the total system mass.

$$\vec{CoM} = \frac{m_1 T_1 \begin{Bmatrix} \vec{c}_1 \\ 1 \end{Bmatrix}}{M} + \frac{m_2 T_1 T_2 \begin{Bmatrix} \vec{c}_2 \\ 1 \end{Bmatrix}}{M} + \frac{m_3 T_1 T_3 \begin{Bmatrix} \vec{c}_3 \\ 1 \end{Bmatrix}}{M} + \frac{m_4 T_1 T_3 T_4 \begin{Bmatrix} \vec{c}_4 \\ 1 \end{Bmatrix}}{M} \quad (1)$$

$$\overline{CoM} = \overline{d}_1 + A_1 \frac{m_1 \overline{c}_1 + m_2 \overline{d}_2 + (m_3 + m_4) \overline{d}_3}{M} + A_1 A_2 \frac{m_2 \overline{c}_2}{M} + A_1 A_3 \frac{m_3 \overline{c}_3 + m_4 \overline{d}_4}{M} + A_1 A_3 A_4 \frac{m_4 \overline{c}_4}{M} \quad (2)$$

The expression is expanded and regrouped according to the individual rotation matrices in (2). Based on the assumptions, the vector associated with each rotation matrix is constant. Replacing these vectors by a single parameter leads us to the final CoM equation (3).

$$\begin{aligned} \overline{r}_2 &= \frac{m_1 \overline{c}_1 + m_2 \overline{d}_2 + (m_3 + m_4) \overline{d}_3}{M} & \overline{r}_3 &= \frac{m_2 \overline{c}_2}{M} \\ \overline{r}_4 &= \frac{m_3 \overline{c}_3 + m_4 \overline{d}_4}{M} & \overline{r}_5 &= \frac{m_4 \overline{c}_4}{M} \end{aligned}$$

$$\overline{CoM} = \overline{d}_1 + A_1 \overline{r}_2 + A_1 A_2 \overline{r}_3 + A_1 A_3 \overline{r}_4 + A_1 A_3 A_4 \overline{r}_5 \quad (3)$$

The similarity is readily observed between equation (3) for the center of mass of the four link branched chain and the equation for the forward kinematics of a four link serial chain. Here, we note the main interest in this approach: the CoM location of the original branched chain is modeled by the end-effector location of an appropriately sized spatial serial-chain. This concept is illustrated by Fig. 2. As a consequence, we can directly apply all the past work dedicated to the control of the end-effector location of serial robots to the control of the CoM.

This concept can be applied generally to a multi-link chain for which we can obtain a Statically Equivalent Serial Chain such that the end-effector locates the original chain's Center of Mass. Moreover, the relationship between the CoM location and joint variables is a straightforward relationship.

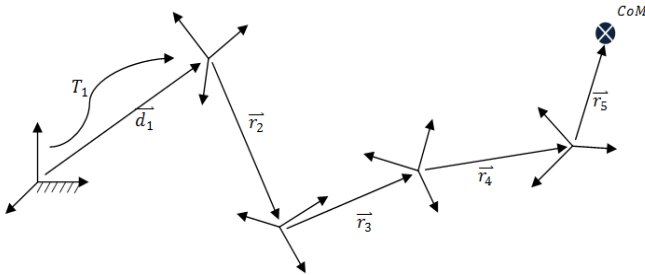

Fig. 2 Statically Equivalent Serial Chain of Fig. 1

C. SESC Model Generalization , Matrix Form

Equation (3) can be written in matrix form.

$$\begin{bmatrix} \overline{CoM} \\ 1 \end{bmatrix} = \begin{bmatrix} A_1 & \overline{d}_1 \\ 0 & 1 \end{bmatrix} \begin{bmatrix} A_2 & \overline{r}_2 \\ 0 & 1 \end{bmatrix} \begin{bmatrix} A_2^T A_3 & \overline{r}_3 \\ 0 & 1 \end{bmatrix} \begin{bmatrix} A_4 & \overline{r}_4 \\ 0 & 1 \end{bmatrix} \begin{bmatrix} \overline{r}_5 \\ 1 \end{bmatrix}$$

The $A_2^T A_3$ term in the previous expression is noteworthy because, although not identical in practice to a serial chain, the form still largely resembles that of a serial chain. We observe that a general branched chain, where for simplicity we

introduce only one branch point, admits an equation for the center of mass location as in (4). The general branched chain under consideration is shown in Fig. 3.

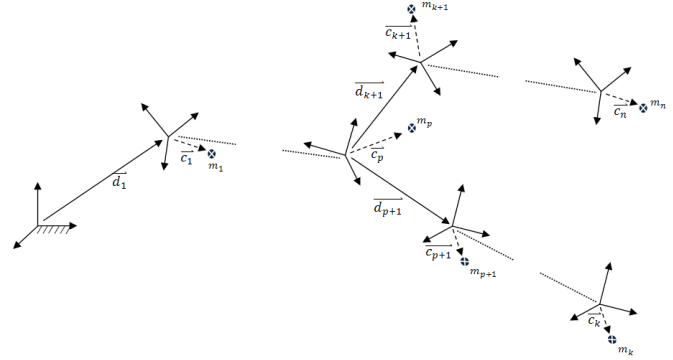

Fig. 3 n Degree of freedom chain with one branch

Finally, the matrix form is useful because it may be formulated to directly produce the CoM equation resulting from the SESC modeling, primarily by observation of the chain structure. Only the \overline{r}_i parameters will require significant calculation.

III. EFFICIENT COMPUTATION OF THE SESC

The modeling can be generalized to automate and efficiently construct the SESC of a given chain. This automation is done by an iterative algorithm which computes for each posture of the chain, its SESC and its CoM location. The algorithm presented below is of interest because it can be used on an n degree of freedom chain and avoid the significant calculation of the \overline{r}_i parameters. Moreover this algorithm extends the modeling to include prismatic joints in addition to the revolute joints. However this algorithm can only be used on symmetrical architecture. Appendix presents, equality between classical CoM computation and CoM computation from equations described in this chapter.

A. Formulate the SESC

To use the structure of a serial chain, we progress along the original chain moving from one joint to the following. All the joints must be included but each joint is included only once. Returning to a previous joint is not a requirement, where instead you have to use an inverted matrix to move along the chain backward and then directly go to the next joint. So, the first thing to do is to define the transformation matrices between each joint of the chain. Then we can write the full equation of the CoM given by the SESC model. The example below shows all the steps to construct a SESC on a four jointed tree.

$$\begin{bmatrix} \overline{CoM} \\ 1 \end{bmatrix} = \begin{bmatrix} A_1 & \overline{d}_1 \\ 0 & 1 \end{bmatrix} \begin{bmatrix} A_2 & \overline{r}_2 \\ 0 & 1 \end{bmatrix} \dots \begin{bmatrix} A_k & \overline{r}_k \\ 0 & 1 \end{bmatrix} \begin{bmatrix} (A_{k-p} \dots A_{k-1} A_k)^T A_{k+1} & \overline{r}_{k+1} \\ 0 & 1 \end{bmatrix} \begin{bmatrix} A_{k+2} & \overline{r}_{k+2} \\ 0 & 1 \end{bmatrix} \dots \begin{bmatrix} A_n & \overline{r}_n \\ 0 & 1 \end{bmatrix} \begin{bmatrix} \overline{r}_{n+1} \\ 1 \end{bmatrix} \quad (4)$$

1) *Define Transformation Matrices:* The transformation matrices in red (Fig. 4) are the matrices used to progress along the chain and therefore used in the following equations.

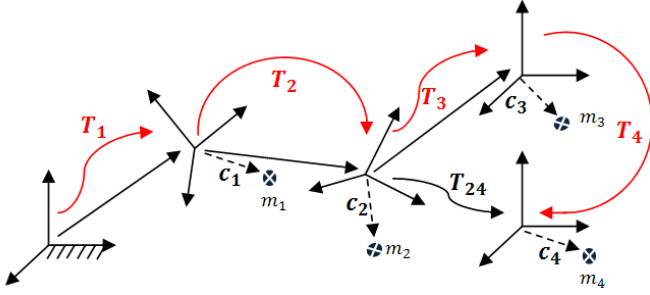

Fig.4 How to define transformation matrices to automatically generate the SESC

2) *Define the chain's parameters:* From the way the chain is constructed, we propose to calculate iteratively the \bar{r}_i parameters according to (5). It is important to notice in this equation that the \bar{d}_i coefficients come from the last column of the transformation matrices used to follow the chain.

$$\bar{r}_i = \frac{m_{i-1} \cdot \bar{c}_{i-1} + \bar{d}_i \cdot \sum_{j=i}^n m_j}{\sum_{k=1}^n m_k} \quad (5)$$

B. Run the SESC Algorithm

1) *The SESC Algorithm:* This algorithm has to be run during the experimentation to re-compute for each posture the transformation matrices at the current joint values. The inputs are the mechanical parameters and the output is the CoM location.

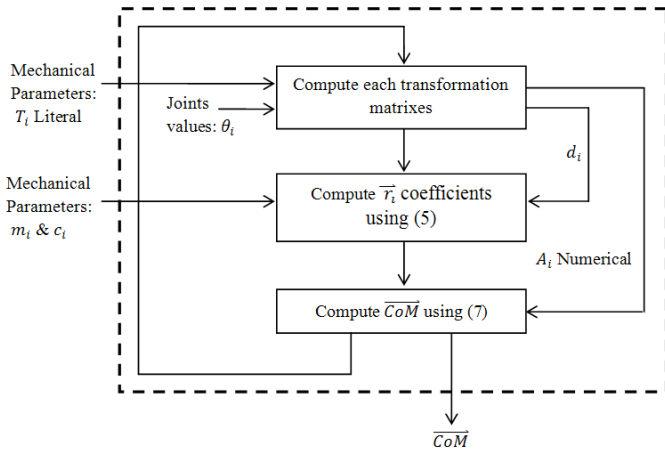

Fig.5 The SESC Algorithm to efficiently compute the Statically Equivalent Serial Chain from the mechanical parameters of a given structure

2) *Final Expression of the Center of Mass:* For a chain composed of n joints, the final expression of the center of mass can be written in its literal form as (6) or in its factored form as (7). As the \bar{r}_i parameters are computed continuously, it is important to notice this algorithm can also be used on

structures with prismatic joints. Indeed, the \bar{r}_i groups the mechanical parameters in which we find the distance between two successive joints.

$$\overline{CoM} = \bar{d}_1 + A_1 \bar{r}_2 + A_1 A_2 \bar{r}_3 + \dots + A_1 A_2 A_3 \dots A_n \bar{r}_{n+1} \quad (6)$$

$$\overline{CoM} = \bar{d}_1 + \sum_{i=2}^{n+1} \left(\prod_{j=1}^{i-1} A_j \right) \cdot \bar{r}_i \quad (7)$$

3) *CoM Jacobian:* An efficient computation of the CoM Jacobian based on the SESC modeling is given in (8). The elements of the CoM Jacobian in their iterative form (9) are readily computed and avoid the handmade calculation of the CoM Jacobian. Moreover this equation can be included in the previous algorithm.

$$J_{CoM} = \left[\frac{\partial \overline{CoM}}{\partial \theta_j} \right], \quad j = 1 \text{ to } n \quad (8)$$

$$\frac{\partial \overline{CoM}}{\partial \theta_j} = \left(\prod_{i=1}^{j-1} A_i \right) \cdot \frac{\partial A_j}{\partial \theta_j} \cdot \left(\bar{r}_{j+1} + \sum_{l=j+2}^{n+1} \bar{r}_l \cdot \left(\prod_{k=j+1}^n A_k \right) \right) \quad (9)$$

IV. AN EXAMPLE USE OF SESC MODELING IN ANTHROPOMORPHIC STRUCTURE BALANCE

A. Maintaining Balance of an Anthropomorphic Structure

A relevant condition to maintain the static balance of an anthropomorphic structure is to keep the point from the projected CoM (in the direction of the gravity force) inside the base of support. The base of support is the surface demarcated by the convex hull made by the pressure points of the structure on the ground.

B. Extension of the SESC Modeling to the CoM Projection

On planar ground, the CoM given by the SESC and its projection (according to the gravity force direction) have the same coordinates in the horizontal plane. It is not the case on non-horizontal ground. As the only variables in the SESC are the joint variables relative to a frame on the robot, when the robot is on sloped ground, the SESC model fails. This leads to potential difficulty during the CoM projection to the ground. Fig. 7 shows the SESC model for the CoM projection in comparison to reality. As the two results are not equal, the result given by the previous SESC modeling is not applicable to the CoM projection. A good solution is to directly include the transformation matrix between the root and the world frames in the SESC model. The rotation part of the transformation matrix includes the rotation by the angle θ_0 , data provided by robot's sensors, typically a gyrometer.

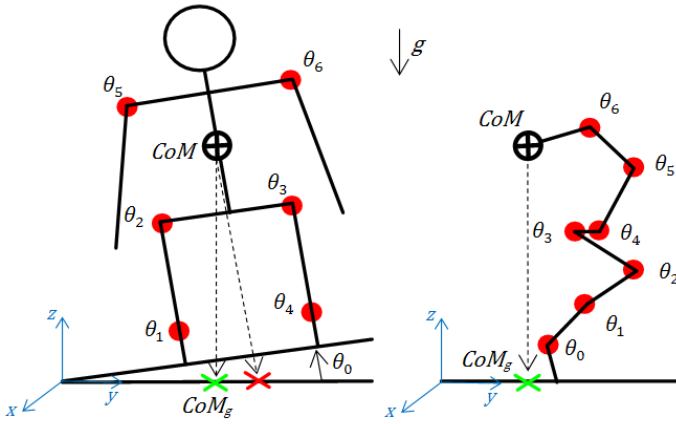

Fig. 7 Real CoM projections vs. SESC CoM projection of an anthropomorphic structure on leaning ground do not have the same coordinates

Adding the ground slope in the SESC model leads to an alternate version of equation (4), directly obtaining the CoM projection. The generalized equation of the CoM projection becomes (10) where A_0 is the rotation matrix of the ground slope. The ground slope can also be included in the automatic generation of the SESC previously presented, in which the equation of the CoM projection is (11).

This modeling is particularly well-suited for control of the static balance because we can directly compensate for the ground slope using a gyrometer embedded in the robot. Here, we emphasize the value of the SESC model because it allows us to balance the anthropomorphic structure just by adding a new virtual joint in the anthropomorphic SESC, representing the ground slope, as shown in Fig. 7.

$$\overline{CoM}_g = A_0 \cdot \left(\overline{d}_1 + \sum_{i=2}^{n+1} \left(\prod_{j=1}^i A_j \right) \cdot \overline{r}_i \right) \quad (11)$$

V. EXPERIMENTAL RESULTS

Two experiments illustrate the previous developments. The first one shows the derivation of the statically equivalent serial chain of the HOAP-3 robot. The algorithm presented in section III is used to efficiently establish its SESC. Indeed, to obtain the exact CoM location in the three dimensional space, we have to account for all of the joints of the robot, which has 21 degrees of freedom. The second experiment displays the capacity of the Hoap-3 robot to place its CoM on leaning ground by using the extension of the SESC model to the CoM projection, as described in the previous section.

A. Hoap-3 SESC

1) *Mechanical Parameters*: We saw in section III.1 that we need the mechanical parameters of the robot as inputs of the

$$\begin{bmatrix} \overline{CoM}_g \\ 1 \end{bmatrix} = \begin{bmatrix} A_0 & 0 \\ 0 & 1 \end{bmatrix} \begin{bmatrix} A_1 & \overline{d}_1 \\ 0 & 1 \end{bmatrix} \dots \begin{bmatrix} A_k & \overline{r}_k \\ 0 & 1 \end{bmatrix} \left[(A_{k-p} \dots A_{k-1} A_k)^T A_{k+1} \overline{r}_{k+1} \right] \begin{bmatrix} A_{k+2} & \overline{r}_{k+2} \\ 0 & 1 \end{bmatrix} \dots \begin{bmatrix} A_n & \overline{r}_n \\ 0 & 1 \end{bmatrix} \begin{bmatrix} \overline{r}_{n+1} \\ 1 \end{bmatrix} \quad (10)$$

SESC algorithm. Thus, we used masses and center of masses given by the Hoap-3 datasheet. The parameters that define the transformation matrices used to relate the robot's joints are presented in Fig. 9.

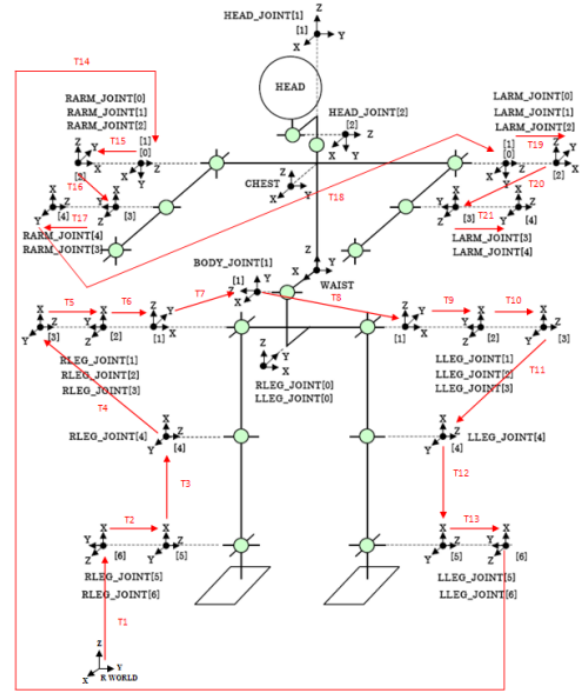

Fig. 9 Parameters used to define the transformation matrices of the Hoap-3 (Original figure from Hoap-3 instruction manual)

2) *Hoap-3 SESC Simulation*: Fig. 10 shows the Statically Equivalent Serial Chain (purple line) obtained by the SESC algorithm with the mechanical parameters defined previously. Notice that the end of the SESC corresponds to the CoM location of the full robot.

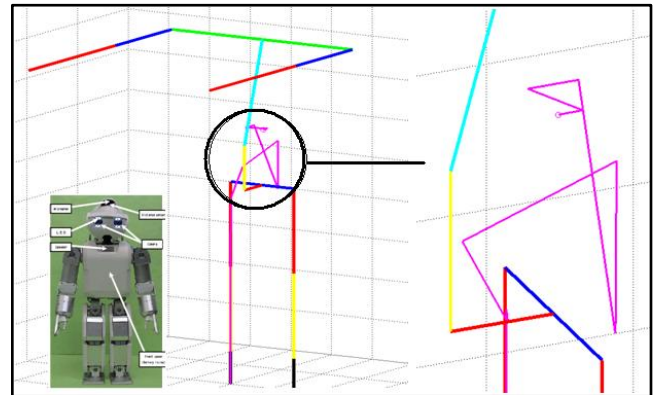

Fig. 10 Hoap-3 Statically Equivalent Serial Chain

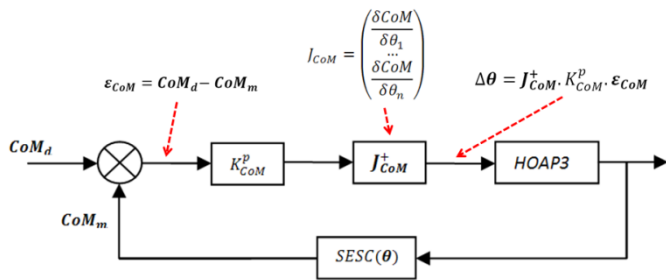

Fig. 11 CoM control loop based on SESC modeling

3) *Hoap-3 SESC implemented on the robot*: The Hoap-3 SESC model has been implemented on the robot controller through real time modules to determine the robot CoM location every millisecond (sample time of the robot). A CoM control loop (Fig. 11) based on this model has been successfully tested. The desired CoM location is the only parameter controlled. Fig. 12 shows several postures where the static balance is managed using this loop.

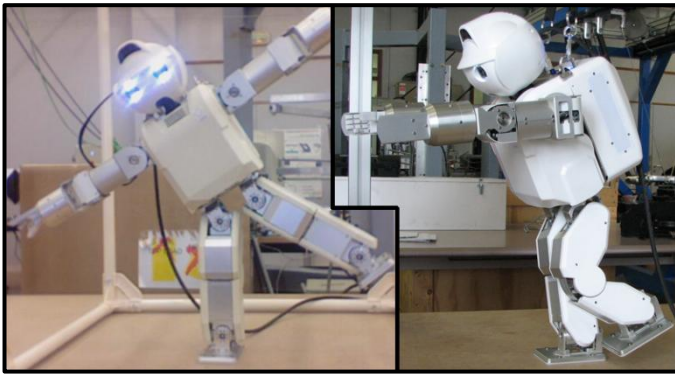

Fig. 12 SESC Modeling used to control CoM in the 3D space

B. Hoap-3 on leaning ground

In this experiment, we aim to manage the robot's static balance on leaning ground. To do that, only the ankle, hip and shoulder joints are used in the frontal plane. Consequently we have a simplified model of the SESC and we control the CoM projection only in the frontal plane.

1) *Hoap-3 CoM projection using SESC modeling*: Six joints are used on the robot. The ground slope θ_0 is represented by a virtual joint at the beginning of the SESC. As a consequence, we can directly obtain the CoM projection \overline{CoM}_g on planar ground, where the root frame is located. The robot on leaning ground and its SESC are illustrated Fig. 7.

2) *Implementation*: The same control scheme presented in Fig. 11 is used to preserve balance on leaning ground. However instead of controlling the CoM location, we control the location the CoM projection. The experiment has been carried out on a surface where the leaning angle is continuously modified. The leaning angle of the ground is estimated by using a three axis gyrometer embedded in the robot. Pictures from the experiment are shown in Fig. 13.

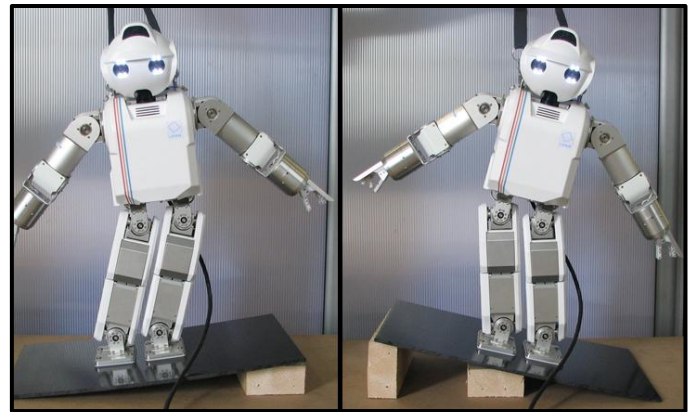

Fig. 13 SESC Modeling used to control CoM Projection on leaning ground

VI. ONGOING RESEARCH

A. CoM Workspace Optimization

As the CoM is the end-effector of a serial chain we can readily express its workspace. This property brings us new opportunities to solve different problems.

1) *Robot Design*: The SESC model gives us the expression of the CoM as a function of the rotation matrix and the mechanical parameters assembled in a single \overline{r}_i parameter. Thus, changing the mechanical parameter values (mass, length and center of mass) will directly modify the CoM workspace. In robot design this property is noteworthy because it allows us, knowing the architecture of the future robot, to optimize its mechanical parameters to obtain the desired CoM workspace. Consequently the future CoM workspace is accounted for during the design phase.

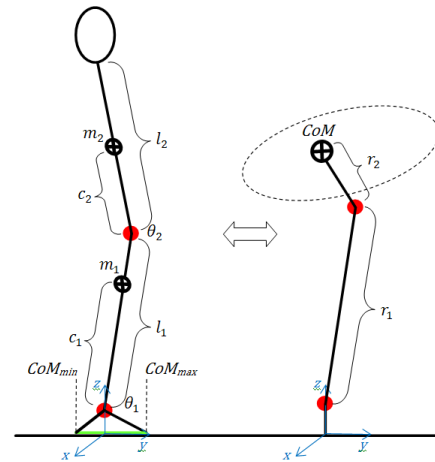

Fig. 14 CoM workspace of a human like structure (L=180cm, M=70kg)

2) *Influence in Anthropomorphic like Structure*: Our working hypothesis is that the CoM workspace may have an influence in the development of an anthropomorphic-like architecture. To verify this claim, we have tried to find a set of mechanical parameters minimizing the CoM workspace of an anthropomorphic-like architecture and compare it to Winter anthropometric table [5]. We solved this optimization problem on a simple case: A two degrees of freedom human like

architecture in the sagittal plane. Only the hip and ankle joints were used. Fig. 14 illustrates the structure and its statically equivalent serial chain. The problem has been solved under the constraints described in (12). The SESC modeling has been used to find the CoM equation, express the cost function and minimize the CoM workspace.

$$\left. \begin{aligned} l_1 + l_2 &= L \\ m_1 + m_2 &= M \\ \theta_{1min} < \theta_1 < \theta_{1max} \\ \theta_{2min} < \theta_2 < \theta_{2max} \\ CoM_{gmin} < CoM_g < CoM_{gmax} \end{aligned} \right\} (12)$$

The optimization problem solved under these constraints gives the same results for length as Winter's anthropometric data. Although this result is promising, we have not yet results for masses distribution. We can explain that by the fact that only the geometric model was taken into account in the optimization problem, and not the dynamic one. Consequently, we hope to find similar results as Winter for length and mass of the legs and body, by taking into account the dynamics of this structure in the optimization problem. Moreover, one of our future works will be to extend this problem by including more degrees of freedom in the studied architecture.

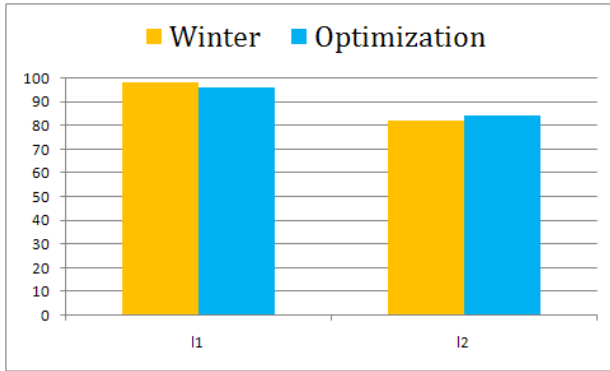

Fig. 15 Lengths for legs and body found by minimizing CoM workspace is the same as winter anthropometric data

B. Identification of Mechanical Parameters on a Given Structure

If we know the geometry of a given structure but not its mechanical parameters, we write the equation of its CoM projection by using the SESC modeling in this matrix form. (Refer to section III.C). For an n degree of freedom architecture, this leads to equation (13). If we put the structure in a neutrally stable (tip over) posture, we know the CoM projection location and the corresponding joint values. So, in equation (14), the \vec{r}_i parameters remain unknown. Choosing m (at least $m = n$) different tip over postures we can write the matrix equality (14) and solve it using inversion (or pseudo-inversion if $m > n$) (15). In equation (14) and (15), $p1 \dots pm$ superscripts stands for tip over posture one to tip over posture m .

$$\overline{CoM_g} = [A_0 \dots A_n] \cdot \begin{bmatrix} \vec{r}_1 \\ \dots \\ \vec{r}_n \end{bmatrix} (13)$$

$$\begin{bmatrix} \overline{CoM_g^{p1}} \\ \dots \\ \overline{CoM_g^{pm}} \end{bmatrix} = \begin{bmatrix} A_0^{p1} & \dots & A_n^{p1} \\ \dots & \dots & \dots \\ A_0^{pm} & \dots & A_n^{pm} \end{bmatrix} \cdot \begin{bmatrix} \vec{r}_1 \\ \dots \\ \vec{r}_n \end{bmatrix} (14)$$

$$\begin{bmatrix} \vec{r}_1 \\ \dots \\ \vec{r}_n \end{bmatrix} = \begin{bmatrix} A_0^{p1} & \dots & A_n^{p1} \\ \dots & \dots & \dots \\ A_0^{pm} & \dots & A_n^{pm} \end{bmatrix}^{-1} \cdot \begin{bmatrix} \overline{CoM_g^{p1}} \\ \dots \\ \overline{CoM_g^{pm}} \end{bmatrix} (15)$$

In theory, with this procedure, we are able to completely calculate the \vec{r}_i parameters of the SESC. Therefore, for all the other postures, we will be able to predict the CoM projection without any knowledge of the mechanical parameters of the studied structure. Note that the transformation from the original chain to its statically equivalent serial chain is an injective transformation. The mechanical parameters of the original structure cannot be obtained. Fig. 16 shows several tips over postures on the Hoap-3 robot used to calculate its SESC.

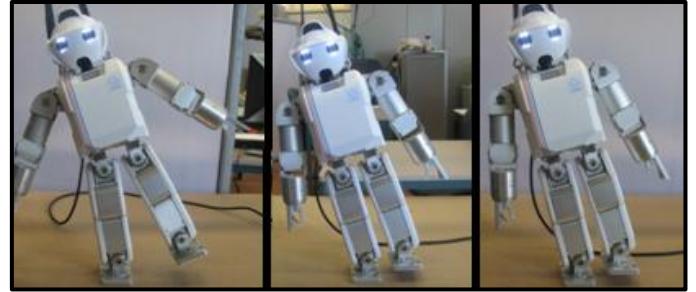

Fig. 16 Some neutrally stable postures used to reconstruct the Hoap-3 SESC

VII. CONCLUSIONS

Statically Equivalent Serial Chain modeling has been presented and has been generalized for use in three dimensional space. The main interest of this modeling resides in the ability to express the CoM of a given structure as the end-effector of a serial chain. Therefore, knowledge of the serial manipulator can be applied directly to the CoM. An algorithm to compute the Statically Equivalent Serial Chain efficiently has been developed and successfully checked on the Hoap-3 robot. Equations to compute the chain parameters and CoM location are noteworthy. Moreover, their iterative form enables the automatic computation of the SESC model for an n degree of freedom symmetric architecture, which is advantage in humanoid robotics where the number of joints is continuously increasing. This algorithm also allows the application of the SESC modeling on architectures including prismatic joints.

To manage the static balance of humanoid robots, SESC modeling has been extended to the CoM projection. The interest in this modeling is highlighted by the facility to include a new revolute joint in the equivalent chain to balance

the robot when it is on tilted ground. In the aim to improve static balance, future work will include minimum energy criteria to address model redundancy.

Finally, we show, the SESC model is not restricted to balance management but it brings new perspectives to solving different kinds of problems. CoM Workspace optimization in robot design or in anthropometric studies and CoM location prediction are good examples of the abilities of SESC modeling.

APPENDIX: CALCULATION DETAILS FOR SESC EFFICIENT COMPUTATION EXAMPLE

This appendix provides the details of the calculations shown in Fig. 4. SES Efficient Computing (section III) gives the same result for the CoM equation as the classical SESC modeling (section II).

A. CoM equation given by SESC Modeling (section II)

$$M. \overline{CoM} = m_1 T_1 \begin{Bmatrix} \overline{c_1} \\ 1 \end{Bmatrix} + m_2 T_1 T_2 \begin{Bmatrix} \overline{c_2} \\ 1 \end{Bmatrix} + m_3 T_1 T_2 T_3 \begin{Bmatrix} \overline{c_3} \\ 1 \end{Bmatrix} + m_4 T_1 T_2 T_3 T_4 \begin{Bmatrix} \overline{c_4} \\ 1 \end{Bmatrix}$$

Expanding and factoring:

$$M. \overline{CoM} = M. \overline{d_1} + A_1 (m_1 \overline{c_1} + \overline{d_2} (m_2 + m_3 + m_4)) + A_1 A_2 (m_2 \overline{c_2} + m_3 \overline{d_3} + m_4 \overline{d_{24}}) + A_1 A_2 A_3 (m_3 \overline{c_3}) + A_1 A_2 A_3 T_4 (m_4 \overline{c_4}) \quad (16)$$

B. CoM equation given by SESC Efficient Computing (Chapter III)

According to equation (5) and (7)

$$\overline{CoM} = \overline{d_1} + A_1 \overline{r_2} + A_1 A_2 \overline{r_3} + A_1 A_2 A_3 \overline{r_4} + A_1 A_2 A_3 A_4 \overline{r_5}$$

Expanding and factoring:

$$M. \overline{CoM} = M. \overline{d_1} + A_1 (m_1 \overline{c_1} + \overline{d_2} (m_2 + m_3 + m_4)) + A_1 A_2 (m_2 \overline{c_2} + \overline{d_3} (m_3 + m_4)) + A_1 A_2 A_3 (m_3 \overline{c_3} + m_4 \overline{d_4}) + A_1 A_2 A_3 A_4 (m_4 \overline{c_4}) \quad (17)$$

Note that the inverse of homogeneous transformation matrix can be express as

REFERENCES

- [1] B. Espiau and R. Boulic, « *On the Computation and control of the mass center of articulated chains* », Research Report INRIA N°3479, 1998.
- [2] B. El Ali, « *Contribution à la commande du centre de masse d'un robot bipède* », Thesis, INPG, France, 1999.
- [3] A. Murray, S. Cotton and P. Fraitse, « *Serial Chain-Like Representations for Determining Center of Mass of Complex Kinematic Chains with Applications to Humanoids* », National Days of Humanoid Robotics, JNRH Montpellier, France, 2007.
- [4] P. Fraitse, S. Cotton, A. Murray and F. Pierrot, « *Towards Dynamic Balance Control of Humanoid Robots by using CoM and ZMP* », Workshop, Pittsburgh, Humanoids 2007
- [5] D. Winter, « *Biomechanics and Motor Control of Human Movement* », Book, Wiley Edition, 2005

$$T_i^{-1} = \begin{bmatrix} A_i^T & -A_i^T \cdot \overline{d_i} \\ 0 & 1 \end{bmatrix} \quad (18)$$

Thus T_4 is:

$$T_4 = T_3^{-1} \cdot T_{24} = \begin{bmatrix} A_3^T \cdot A_{24} & A_3^T \cdot \overline{d_{24}} - A_3^T \cdot \overline{d_3} \\ 0 & 1 \end{bmatrix}$$

$$A_4 = A_3^T \cdot A_{24}$$

$$\overline{d_4} = A_3^T \cdot \overline{d_{24}} - A_3^T \cdot \overline{d_3}$$

Replacing A_4 and $\overline{d_4}$ in equation (17)

$$M. \overline{CoM} = M. \overline{d_1} + A_1 (m_1 \overline{c_1} + \overline{d_2} (m_2 + m_3 + m_4)) + A_1 A_2 (m_2 \overline{c_2} + \overline{d_3} (m_3 + m_4)) + A_1 A_2 A_3 (m_3 \overline{c_3} + m_4 (A_3^T \cdot \overline{d_{24}} - A_3^T \cdot \overline{d_3})) + A_1 A_2 A_3 A_3^T A_{24} (m_4 \overline{c_4})$$

$$M. \overline{CoM} = M. \overline{d_1} + A_1 (m_1 \overline{c_1} + \overline{d_2} (m_2 + m_3 + m_4)) + A_1 A_2 (m_2 \overline{c_2} + \overline{d_3} (m_3 + m_4)) + A_1 A_2 (m_4 \overline{d_{24}} - m_4 \overline{d_3}) + A_1 A_2 A_3 (m_3 \overline{c_3}) + A_1 A_2 A_{24} (m_4 \overline{c_4})$$

$$M. \overline{CoM} = M. \overline{d_1} + A_1 (m_1 \overline{c_1} + \overline{d_2} (m_2 + m_3 + m_4)) + A_1 A_2 (m_2 \overline{c_2} + m_3 \overline{d_3} + m_4 \overline{d_{24}}) + A_1 A_2 A_3 (m_3 \overline{c_3}) + A_1 A_2 A_{24} (m_4 \overline{c_4}) \quad (19)$$

Equations (16) and (19) are very same.