

RESEARCH ARTICLE

## Evolutionary process of a tetranucleotide microsatellite locus in Acipenseriformes

ZHAO JUN SHAO<sup>1,3,4\*</sup>, ERIC RIVALS<sup>2</sup>, NA ZHAO<sup>1</sup>, SOVAN LEK<sup>3</sup>, JIANBO CHANG<sup>1</sup> and PATRICK BERREBI<sup>4</sup>

<sup>1</sup>*Institute of Hydroecology, Ministry of Water Resources, Chinese Academy of Sciences, Wuhan 430079, People's Republic of China*

<sup>2</sup>*Methods and Algorithms for Bioinformatics, L.I.R.M.M., UMR 5506 CNRS - Université de Montpellier II, CC 477, 161 rue Ada, F-34095 Montpellier Cedex 5, France*

<sup>3</sup>*Ichthyology and Ecological Modelling, UMR 5174 - Lab. EDB (Evolution Diversité Biologique), University of Paul Sabatier – CNRS, 31062 Toulouse Cedex 4, France*

<sup>4</sup>*Institut des Sciences de l'Evolution (UMR UM2-CNRS 5554) University Montpellier II, cc 065. Place E. Bataillon 34095 Montpellier Cedex 5, France*

### Abstract

The evolutionary dynamics of the tetra-nucleotide microsatellite locus *Spl-106* were investigated at the repeat and flanking sequences in 137 individuals of 15 Acipenseriform species, giving 93 homologous sequences, which were detected in 11 out of 15 species. Twenty-three haplotypes of flanking sequences and three distinct types of repeats, type I, type II and type III, were found within these 93 sequences. The MS-Align phylogenetic method, newly applied to microsatellite sequences, permitted us to understand the repeat and flanking sequence evolution of *Spl-106* locus. The flanking region of locus *Spl-106* was highly conserved among the species of genera *Acipenser*, *Huso* and *Scaphirhynchus*, which diverged about 150 million years ago (Mya). The rate of flanking sequence divergence at the microsatellite locus *Spl-106* in sturgeons is between 0.011% and 0.079% with an average at 0.028% per million years. Sequence alignment and phylogenetic trees produced by MS-Align showed that both the flanking and repeat regions can cluster the alleles of different species into Pacific and Atlantic lineages. Our results show a synchronous evolutionary pattern between the flanking and repeat regions. Moreover, the coexistence of different repeat types in the same species, even in the same individual, is probably due to two duplication events encompassing the locus *Spl-106* that occurred during the divergence of Pacific lineage. The first occurred before the diversification of Pacific species (121–96 Mya) and led to repeat types I and II. The second occurred more recently, just before the speciation of *A. sinensis* and *A. dabryanus* (69–10 Mya), and led to repeat type III. Sequences in the same species with different repeat types probably corresponds to paralogous loci. This study sheds a new light on the evolutionary mechanisms that shape the complex microsatellite loci involving different repeat types.

[Shao Z. J., Rivals E., Zhao N., Lek S., Chang J. and Berrebi P. 2011 Evolutionary process of a tetranucleotide microsatellite locus in Acipenseriformes. *J. Genet.* **90**, 217–227]

### Introduction

Microsatellites are tandemly repeated short sequences widely dispersed throughout most eukaryotic genomes. Because of their highly polymorphic allele size caused by changes in repeat number, microsatellites are very popular genetic markers in population genetics and other evolutionary studies (Goldstein and Schlötterer 1999). However, the evolution of microsatellites themselves needs to be investigated, because the molecular mechanisms that generate microsatellites is not

completely understood. There are several ways to examine the evolutionary process of microsatellites.

Theoretically, some mutational models have been proposed, i.e. (i) the infinite allele model (IAM; Kimura and Crow 1964), which assumes that microsatellite mutations may create an infinite number of repeated units and allelic states not present in the population; (ii) the stepwise mutation model (SMM; Kimura and Ohta 1978), in which microsatellite mutations have the same probability of gaining or losing one repeat unit; (iii) the generalized stepwise model (GSM) or two phase model (TPM; Di Rienzo *et al.* 1994), an

\*For correspondence. E-mail: zhjshao@gmail.com.

**Keywords.** microsatellite evolution; homologous sequences; sturgeon phylogeny; sequence alignment; tandem repeat alignment; MS-Align.

extension of the SMM model considering the probability for a microsatellite mutation to involve more than one unit; (iv) the *K*-allele model (KAM; Crow and Kimura 1970), where there are *K* allelic states and equal probabilities to mutate towards any of the other *K*-1 alleles.

Another straightforward and conclusive way of investigation is by direct observation of microsatellites in pedigrees. For example, Messier *et al.* (1996), mapped microsatellite sequences onto a phylogeny, and revealed the ‘birth’ of two microsatellites. Similarly, Taylor *et al.* (1999a) characterized microsatellite ‘death’ by placing the interrupted microsatellite sequences into a phylogeny. Moreover, many other studies focussed on phylogenetic and comparative genomic evidence for microsatellite evolution (Li *et al.* 1996; Ortí *et al.* 1997; Zhu *et al.* 2000; Chirhart *et al.* 2005; Leclercq *et al.* 2010).

It is accepted that the high polymorphism of microsatellites is mainly caused by replication slippage, which leads to the allelic length variation (Levinson and Gutman 1987). Previous studies have demonstrated that the repetitive sequences also contain many mutational events other than allelic length changes, such as base substitution and insertion/deletions (reviewed in Estoup *et al.* 2002). In general, when microsatellites are applied as genetic markers, only the allelic size variations information based on the electromorphs are used to analyse the genetic structure of populations or phylogenetic relationships, while the basic sequence variation information caused by substitution or indels is neglected. The consequence is that homoplasy is frequent in most studies based on microsatellite length polymorphism.

Basic variation information in the repeat sequences is then useful for investigation of sequence evolutionary process and the mechanism of microsatellite evolution. One of the methods should be to organize logically the allele sequences (cladistic tree) and to compare it with species phylogeny. However, because of the insertion or deletion of entire repeated blocks of nucleotides, the classical sequences alignment methods are not suitable for repetitive structure.

By-product of repeated region sequences, the substitution rate in microsatellite flanking sequences is similar to that in intron sequences (Brohede and Ellegren 1999), and microsatellite flanking sequences can be specific to each locus and informative for phylogenetic relationship investigation among alleles, populations and species (Zardoya *et al.* 1996; Makova *et al.* 2000). Flanking region evolution can be regarded as a part of the repeated region evolution, being a cause or a consequence of some mutational events modifying the repeat structure.

To extract the basic variation information, other than length variation, in microsatellites alleles sequences, a new alignment method, the MS-Align program (Bérard and Rivals 2003), which was successfully applied on minisatellite sequences (Bonhomme *et al.* 2007), have been applied in this study on microsatellite allele sequences. With this method, both the length variation and basic sequence variations were considered in the analysis.

The biological model on which this method is applied in this study is the order Acipenseriformes which includes 25 extant sturgeons and two paddlefish species. The phylogenetic relationships of this group have been investigated based on the mitochondrial gene sequences (Krieger *et al.* 2008) and morphological evidence (Artyukhin 2006). A comprehensive tree has been reconstructed by combining eight presently available mitochondrial gene sequences (4406 bp) (Krieger *et al.* 2008). In addition, five nuclear genes, *18S* rRNA gene (Krieger and Fuerst 2002), *5S* rDNA gene (Robles *et al.* 2005), *HindIII* and *PstI* satellite sequences (Robles *et al.* 2004) and RAPD markers (Comincini *et al.* 1998), have been examined for phylogenetic analysis, confirming most topology, but brought no new decisive information with them.

Having a look at the systematics, several discrepancies still exist between the phylogenetic trees based on molecular and morphological data:

- The most basal group is composed of the genera *Polyodon* and *Psephurus* (the American paddlefish and Chinese swordfish, respectively);
- Then comes the two species, *Acipenser sturio* and *A. oxyrinchus*, the European and Atlantic sturgeons, sister species, considered as ancestral while showing classical sturgeon morphology;
- An intermediate group composed of three species of the genus *Scaphirhynchus* (pallid, shovelnose and Alabama sturgeons) breaks the monophyly of the *Acipenser* genus;
- Finally, most sturgeons belong to a monophyletic group, the ‘sturgeons sensu stricto’ or ‘true sturgeons’, split into two geographic lineages: the Atlantic and the Pacific sturgeons. This structure is contradicted by the nomenclature: included in the ‘true sturgeons’ are the genus *Huso* composed of two species, one species in each geographic lineage and the genus *Pseudoscaphirhynchus*, composed of three species.

The contradictions between phylogeny and taxonomy have still to be resolved, such as the monophyly (and so the relevance) of genus *Huso*, and the basal position of two Atlantic sturgeons (*A. sturio* and *A. oxyrinchus*), which is not highlighted in the nomenclature (logical necessity of a distinct genus for these two species).

In this study, the conservation of the flanking sequences and the high variation of repeat sequences in microsatellite locus *Spl-106* among sturgeon species provided us the opportunity to understand the sequence evolution of this locus across the Acipenseriform species. We attempted to use the sequence variation both at the flanking and repeat region.

Understanding the microsatellite sequence evolution of locus *Spl-106* as a model was the first objective. Checking if the nuclear new information provided here confirms published phylogenies based on mtDNA sequences, mainly Peng *et al.* (2007) and Krieger *et al.* (2008) was the second objective. The new information was also to be confronted with the systematics anomalies given above.

**Materials and methods**

**Sturgeon samples**

Fin or muscle samples were collected in sturgeon farms, sturgeon research institutes or laboratories in different countries and preserved in 95% ethanol, except for *Scaphirynchus platyrhynchus*, for which the original sequence of microsatellite locus *Spl-106* was downloaded from database (GenBank: AF276175, McQuown *et al.* 2000). For each species, the sample size, quality, origin, collection sites and providers are listed in table 1.

**Molecular methods**

DNA extraction, PCR programme, electrophoreses, gel extraction of PCR products, TA cloning and sequencing procedures are same as described in Shao *et al.* (2005). The primer sequences of *As-100*, 5'-GGGAGAAAAGTGGGGTAAA-3' and 5'-CCAAAAGAAGAATGGTAGACGG-3' (Shao *et al.* 2002), were used in the present study for all samples. The IAquick Gel Extraction kit (Qiagen, Shanghai, China) was used to extract each of the PCR products with the size between 100 bp and 500 bp from the 4% intermediate melting temperature (75°C) MetaPhor<sup>®</sup> agarose

(FMC BioProducts, Rockland, ME, USA) gel which can separate 4 bp difference alleles. Since some sturgeon species are polyploidy species, such as *A. sinensis*, if some individuals have more than two bands with size between 100 bp and 500 bp, we extracted all of them. The TA cloning kit (Takara Biotech, DaLian, China) and DH5 $\alpha$  or DE3 competent cells were used to clone the PCR products. Unilateral sequencing of inserted DNA was performed on an ABI PRISM 377 DNA sequencer (PE Applied Biosystems, Foster City, CA, USA). For each PCR product fragment, at least three clones were sequenced in order to obtain at least two identical sequences of each extracted PCR product from the gel. However, the nonidentical sequences with the same size would also be used in alignment for discovering the homoplasmy sequences and evolutionary process of microsatellites.

**Data analysis**

The flanking and repeat sequences were aligned separately because of their structure differences. The flanking sequences were aligned by using the Clustal X version 1.81 Program (Thompson *et al.* 1997) and checked by hand.

**Table 1.** Specimen information of 15 sturgeon species studied.

Species	Abbr. of species name	Sample size	Quality (wild/W or farm/F)	Number of chromosomes <sup>a</sup>	Ploidy level <sup>c</sup>	Origin	Sample providers <sup>d</sup>
<i>Scaphirynchus platyrhynchus</i> Pacific lineage	SP	1	W	120	2n	USA	GenBank: AF276175
<i>Acipenser sinensis</i>	AS	15	W	264 $\pm$ ?	4n	China	Ms Xiao H. Dr Wei Q. W.
<i>A. dabryanus</i>	AD	10	F (owi) <sup>b</sup>	?	4n	China	Mr Zhou S. W.
<i>A. schrenckii</i>	AK	10	F (owi)	240	4n	China	Mr Ma G. J.
<i>Huso dauricus</i>	HD	13	F (owi)	120	2n	China	Mr Ma G. J.
<i>A. transmontanus</i>	AT	10	W	226-288	4n	USA	Dr Congiu
Atlantic lineage							
<i>A. baerii</i>	AB	9	F	236-256	4n	Russia	Mr Ma G. J.
		10	F			Russia	Dr Congiu
<i>A. naccarii</i>	AN	10	6W, 4F	232-254	4n	Italy	Dr Congiu
<i>A. fulvescens</i>	AF	10	W	262 $\pm$ 6	4n	USA	Dr Congiu
<i>H. huso</i>	HH	4	F	116-128	2n	Italy	Dr Congiu
<i>A. gueldenstaedtii</i>	AG	5	F	239-264	4n	Russia	Dr Congiu
		5	F			Russia	Mr Lan Z. Q.
		1	F			-	Anonymous
<i>A. stellatus</i>	AL	2	F	114-152	2n	Russia	Mr Lan Z. Q.
<i>A. ruthenus</i>	AR	10	F	114-122	2n	France	Mr Lan Z. Q.
<i>A. sturio</i>	Stu	11	W	116 $\pm$ 4	2n	France	Dr Rochard E.
<i>Psephurus gladius</i>	Pgl	1	W	?		China	KunShan,
<i>Polyodon spathula</i>	Psp	1	F	120	2n	USA	Anonymous

<sup>a</sup>The chromosome numbers were referred from <http://web.unife.it/progetti/geneweb/sturgeon.html>, in which different chromosome numbers for each species from different literatures were collected from published literatures by Dr Fontana.

<sup>b</sup>Owi means offsprings of wild individuals.

<sup>c</sup>Ploidy levels of Acipenseriformes were referred from Peng *et al.* (2007).

<sup>d</sup>Ms Xiao Hui, Institute of Chinese sturgeon, YiChang, P. R. China; Dr Wei Qiwei, Institute of Yangtze River Fisheries, JingZhou, P. R. China; Mr Lan ZeQiao, TianXia Sturgeon Fishery Ltd., YiChang, P. R. China; Dr Leonado Congiu, University of Ferrara, Italy; Mr Ma GuoJun, Institute of Amur River Fisheries, P. R. China; Mr Zhou ShiWu, Institute of Rare Aquatic Animals, YiBin, P. R. China; Dr Eric Rochard, Cemagref, France.

The maximum-likelihood phylogenetic tree of flanking sequences was constructed by the online software PhyML (Guindon and Gascuel 2003) through the bioinformatics platform Phylogeny.fr on the internet website <http://phylogeny.lirmm.fr> (Dereeper et al. 2008), using the default parameters.

The evolutionary relationships of the repeat region among sequences were constructed based on the alignment distances computed with the MS-Align program (Bérard and Rivals 2003). This program can extract all the information included in repeated DNA sequences, which is impossible to do using classical sequence alignment methods. Considering only the differences in the number of repeats is also inappropriate, since *Spl-106* is composed of distinct repeated units, called variants (mainly 'GAAA', 'TAAA' and 'TAGA'), most of which are 4-nucleotides long and A/T rich, and probably derived from each other by point mutations (Shao et al. 2005). Indeed, alleles of the same or similar length can be completely different in sequence.

To apply this method on tetra-nucleotide repeat sequences, we encoded the repeat unit with letters (see figure 4). To realistically reflect the similarity of distinct repeat units, we weighted the changes between variants (or units) in the alignment, e.g., changing the variant TAGA into TAAA or vice-versa costs the weight of a nucleotide substitution in the alignment score. Computing an alignment score between all homologous sequences pairs yielded a matrix of pairwise distances between sequences (Bérard et al. 2006). We then fed this distance matrix into FastME (Desper and Gascuel 2002), a variation of the neighbour-joining (NJ) algorithm, to reconstruct a tree representing the relationships among sequences.

Another point is to estimate the robustness of the tree with respect to the alignment parameters and the level of confidence in its internal nodes. For this, we repeated the analysis with 19 sets of parameters and, each time, computed two mathematical measures: the variance accounted for (VAF), also known as percentage of explained variance, and the rate of elementary well-designed quartets (Re). The formula for the VAF and Re are detailed in Guenoche and Garreta (2000). The VAF quantifies the adequacy of representing the distances within a tree, while the Re gives a confidence value for each internal edge as the percentage of quartets supporting the split of this edge. Both measures are comprised in [0,1]. According to these two measures we chose the best tree among all 19 analyses. The complete protocol of this analysis has already been used for instance in Bonhomme et al. (2007), where it is more detailed.

To simply compare the repeat structures among sequences, the encoded (letters) sequences of the repeat region (including repeat-like (RL) region, see Results) were aligned by Clustal X version 1.81 program (Thompson et al. 1997) and checked by hand. Since the Clustal X program can only recognize the sequences composed of G, A, T and C, we used G, A and T to encode the three main repeat units (e.g., G = TAGA, A = TAAA, T = GAAA), and used C to encode all the other rare variable units. After alignment,

to avoid the confusion between encoding sequence and nucleotide sequence, and to make the encoding map readable, we replaced G, A and T with L, O and J, respectively, and replaced C with other letters for different variable units (figure 4).

## Results

The primer set *As-100* successfully amplified in 13 out of the 15 species, failing in *A. naccarii* and *Psephurus gladius*, probably due to bad quality of samples. Among the 220 sequenced PCR products of the 13 species, 93 different homologous sequences were detected in 11 of 13 species. No homologous sequence of locus *Spl-106* was detected among the PCR products from two species, *Acipenser sturio* and *Polyodon spathula*.

Among 220 sequenced PCR products of the 13 species, 122 of them contained conserved flanking region of the target locus *Spl-106* with flanking region identity level higher than 96%, 46 sequences from *A. sinensis* and *A. dabryanus* were less conserved (identity = 89%) due to the 11-bp deletion in the 3'-end (figure 1), while the remaining 52 sequences from different species contained flanking region with less than 79% identity to that of *Spl-106*. The flanking sequences of *P. spathula* and *A. sturio* have less than 75% identity and the repeat structures of these sequences were also different from that of *Spl-106*. As we did not observe any flanking sequence with a percentage of identity between 79% and 89%, we excluded from further analysis of all PCR products whose flanking regions exhibit a percentage of identity lower than 79%, as they probably originate from other loci than *Spl-106*. Finally, 93 different homologous sequences of locus *Spl-106* were recorded from 11 species for further analysis.

### Flanking region

Excluding the RL region, the length of the flanking region of locus *Spl-106* is 131–132 bp in most alleles, while it is 120 bp in alleles of *A. sinensis* and *A. dabryanus* because of the 11-bp deletion. No mutation occurred in the 20 bp 3'-primer sites, so we did not show it in figure 1. Including the original sequence SP205 from *S. platyrhynchus* (Shao et al. 2002), 23 haplotypes of flanking sequences were observed among the 94 homologous sequences (figure 1). Four haplotypes gathered the most common types, accounting for 70 of the 94 sequences (i.e., T1-19, T2-13, T3-16 and T4-22). The remaining 19 rare haplotypes were observed from one (i.e., haplotypes names beginning with two specific letters) to four sequences (i.e., haplotypes T1-2a, T1-4 and T1-2b).

Compared to the original sequence SP205, two common mutation sites were observed among the 93 new sequences (positions 38–40 and position 69), and they are the only mutations observed in haplotype T4-22, from which all the other sequences evolved by a few point mutations. Below

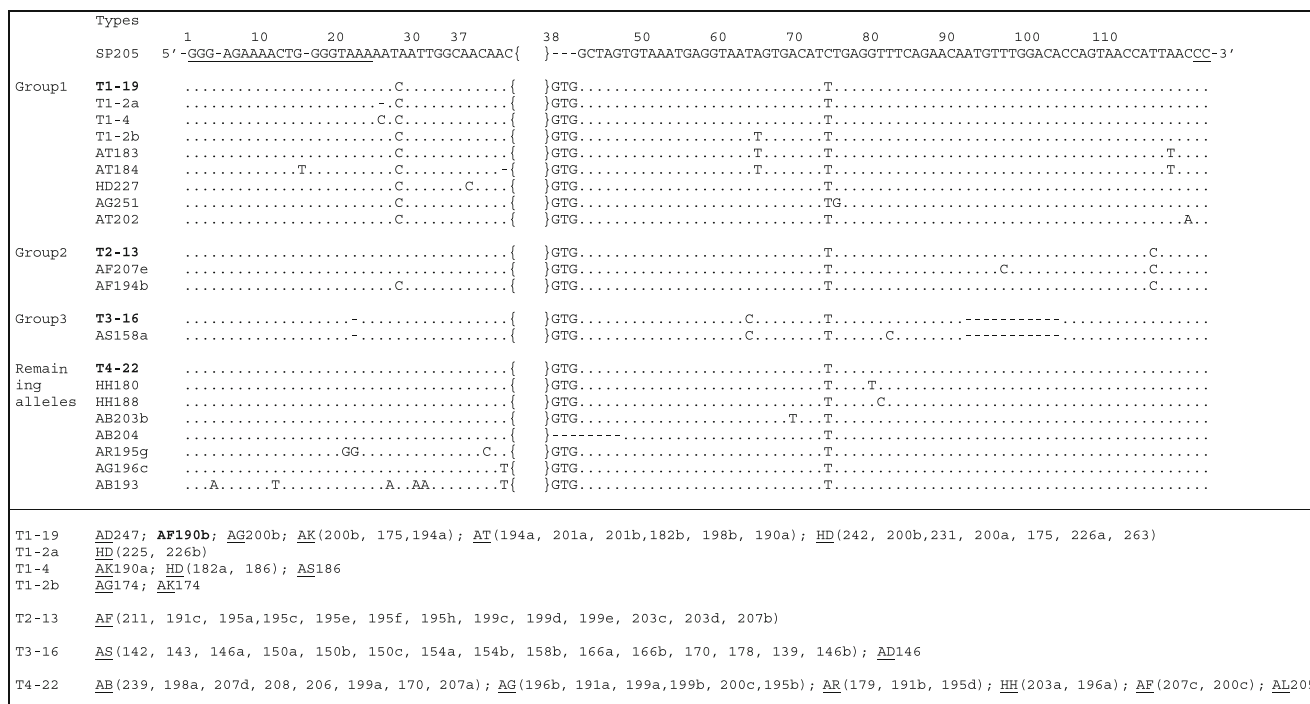

**Figure 1.** Sequence alignments of 23 haplotypes in the flanking region of locus *Spl-106*. The parentheses between position 37 and 38 indicate the repeat region. 5'-primer site is underlined on the left side, while 3'-end primer site is omitted on the right side of this map because no mutations occurred in this primer region. Dots indicate identical sequences. Dashes indicates deletions. The dominant haplotypes were named T1 to T4 with the number of alleles behind them. For example, T4-22 means that the T4 haplotype present in 22 alleles, and the name of these alleles for each haplotype are listed under the alignment map. Rare haplotypes, which is present in only one allele, were named directly with the code of corresponding allele.

the haplotype T4-22, in figure 1, there are seven different haplotypes, which appear only one time each. Except T4-22 and these seven rare haplotypes; all the other haplotypes can be classified into three groups according to the group-specific mutations (figure 1). Each group includes a common haplotype, i.e. T1-19, T2-13 and T3-16, respectively. This classification is supported by the maximum-likelihood phylogenetic tree based on the flanking haplotypes sequences (high-bootstrap values for the splits leading to the groups; see figure 2).

It is noticeable that group 1 encompasses sequences of five species of Pacific lineage: *A. sinensis*, *A. dabryanus*, *H. dauricus*, *A. schrenckii* and *A. transmontanus* (but also four exceptions from Atlantic lineage species: the three alleles of one tetraploid *A. gueldenstaedtii* individual (AG251, AG200b and AG174) and one allele of *A. fulvescens* (AF190b)); group 2 can be recognized as species-specific haplotypes of *A. fulvescens*; group 3 gathers sequences only from the sister species pair *A. sinensis* – *A. dabryanus* of Pacific lineage (figure 1). The haplotype T4-22 and the seven rare haplotypes belong to six sturgeon species of Atlantic lineage (*A. gueldenstaedtii*, *A. baerii*, *A. stellatus*, *A. ruthenus*, *A. fulvescens* and *H. huso*).

According to divergence time of Acipenseriformes estimated by Peng *et al.* (2007) and the pairwise Jukes–Cantor distance of haplotypes calculated by MEGA 4.0 (Tamura

*et al.* 2007), we estimated the evolutionary rate of the flanking sequence (table 2). The average sequence divergence rate of the flanking region of this locus in Acipenseriformes is

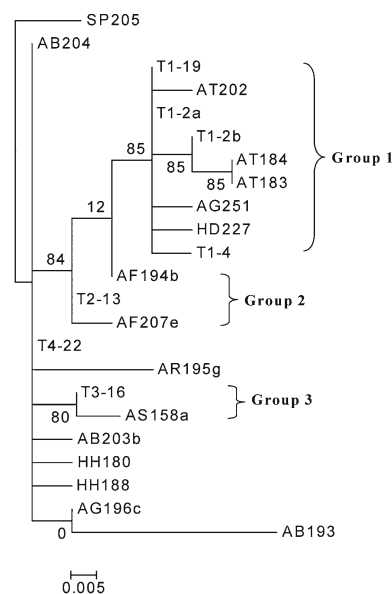

**Figure 2.** Maximum-likelihood phylogenetic tree of the flanking sequences reconstructed by the program PhyML (Guindon and Gascuel 2003) using the default parameters.

$0.278 \times 10^{-9}$  with a range from 0.106 to  $0.789 \times 10^{-9}$  per site per year.

### Repeat-like region

Between the 5'-end flanking and the repeat regions, an interrupted RL poly (A) structure  $T(A)_nTAAA$  distinguishes the Pacific and Atlantic lineages, with  $n = 5$  to 7 (mainly 7) in the sequences of Pacific species and  $n = 8$  or 9 in Atlantic (figure 4). We included it as a part of repeat region because of its variable RL structure and of its special position. The RL region appears at both sides of the repeat region in several sequences from Pacific species, while it was absent in some others (see figure 4, Pacific group).

### Repeat region

The pairwise divergence of the repeat regions of the 94 homologous sequences was estimated by the tandem repeat alignment program MS-Align (Bérard *et al.* 2006). This yielded a pairwise distance matrix, which served to reconstruct a NJ tree representing the relationships among homologous sequences. To understand the effect of the variable RL region on the tree topology, we inferred two trees, one based on repeat region with RL region (tree I in figure 3, VAF = 0.95, Re = 0.54 at the root) and other without RL region (tree II, VAF = 0.99, Re = 0.52 at the root). Both trees share a similar topology; only few sequences are placed differently. Except for the solely branched sequence SP205 in both trees and the sequence AB239 in tree I, all other sequences were basically clustered into two nodes (support value Re = 0.62 (up node) and 0.63 (down node) in tree I; Re = 0.77 (up) and 0.81 (down) in tree II) due to the differences in the composition of repeat units and in number of copies of the three main repeat units (see figure 4). At the exception of six sequences (AR195g, AG199a, AB199a, HD175, AK175 and AT201b) placed within clade AS–AD (*A. sinensis* and *A. dabryanus*, tree I), further split clades are entirely Pacific or Atlantic. Although the sequences of the Atlantic group are

not clustered in one well-supported clade in tree II, the division of Pacific and Atlantic groups are still obvious. Only one small Pacific/Atlantic mixed clade (Re = 0.64) is observed in tree II. However, inside this mixed clade, the next nodes split individuals of Pacific and Atlantic species with higher support values as well.

The repeat structures were compared between the sequences from species of Pacific and Atlantic lineages in figure 4. We found no identical repeat structure between sequences of Pacific and Atlantic lineages, while identical sequences were often observed among species within the lineage. The only exceptions are the four sequences from two species of Atlantic lineage: three AG alleles: AG251, AG200b and AG174, and one *A. fulvescens* allele: AF194b, which contain the same repeat structure or RL region as sequences of Pacific lineage species. Since the three AG alleles (AG251, AG200b and AG174), found in the same individual (given by an anonymous small fish farm, see table 1), unexpectedly belong to the Pacific lineage both at the flanking and repeat structure, the species of this individual is probably misidentified. Thus, we excluded these three alleles from further discussion.

The basic structures of the repeat region were diversified among species, even within species. Three main types of compound repeat structures were observed: type I:  $(TAGA)_n(TAAA)_m$  with the repeat number  $n$  greater than  $m$  ( $n = 12-23$ ;  $m = 5-7$ ); Type II:  $(TAGA)_n(TAAA)_m$  with  $n$  less than or equal to  $m$  ( $n = 2-7$ ;  $m = 5-12$ ); type III:  $(TAAA)_m(GAAA)_n$  with  $m$  greater than  $n$  ( $m = 3-11$ ;  $n = 0-4$ ). The difference between types I and II is mainly due to the different repeat number of the two basic repeat units, and the sequences with these two repeat types can have the same flanking haplotypes and RL region, for instance the sequences with flanking haplotype T1-19 (in figures 1 and 4). However, the sequences with type III repeats not only have very different basic repeat units, but also have an 11-bp sequence deletion in the flanking region (haplotypes of group 3 in figure 1) and even no RL region at all (figure 4). The distribution of repeat types in species were clarified in

**Table 2.** Estimation of evolutionary rate of microsatellite-flanking sequences in sturgeons.

Pairwise comparisons <sup>a</sup>	Divergence time (My) Peng <i>et al.</i> (2007)	Jukes–Cantor distance	Evolutionary rate ( $\times 10^{-9}$ )
SP-T4	74.4 (150.8–86.4)	0.0079	0.106
SP-T3	140.3 (150.8–10.5)	0.0176	0.125
SP-T1	54.6 (150.8–96.2)	0.0159	0.292
SP-T2	98.1 (150.8–52.7)	0.0159	0.162
T4-T3	75.9 (86.4–10.5)	0.0085	0.112
T4-T1	9.8 (86.4–96.2)	0.0077	0.789
T4-T2	33.7 (86.4–52.7)	0.0077	0.229
T3-T1	85.7 (10.5–96.2)	0.0171	0.200
T3-T2	42.2 (10.5–52.7)	0.0171	0.406
T1-T2	43.5 (96.2–52.7)	0.0155	0.357
Average			0.278

<sup>a</sup>SP indicates SP205, T1, T2, T3 and T4 are the four most common flanking haplotypes.

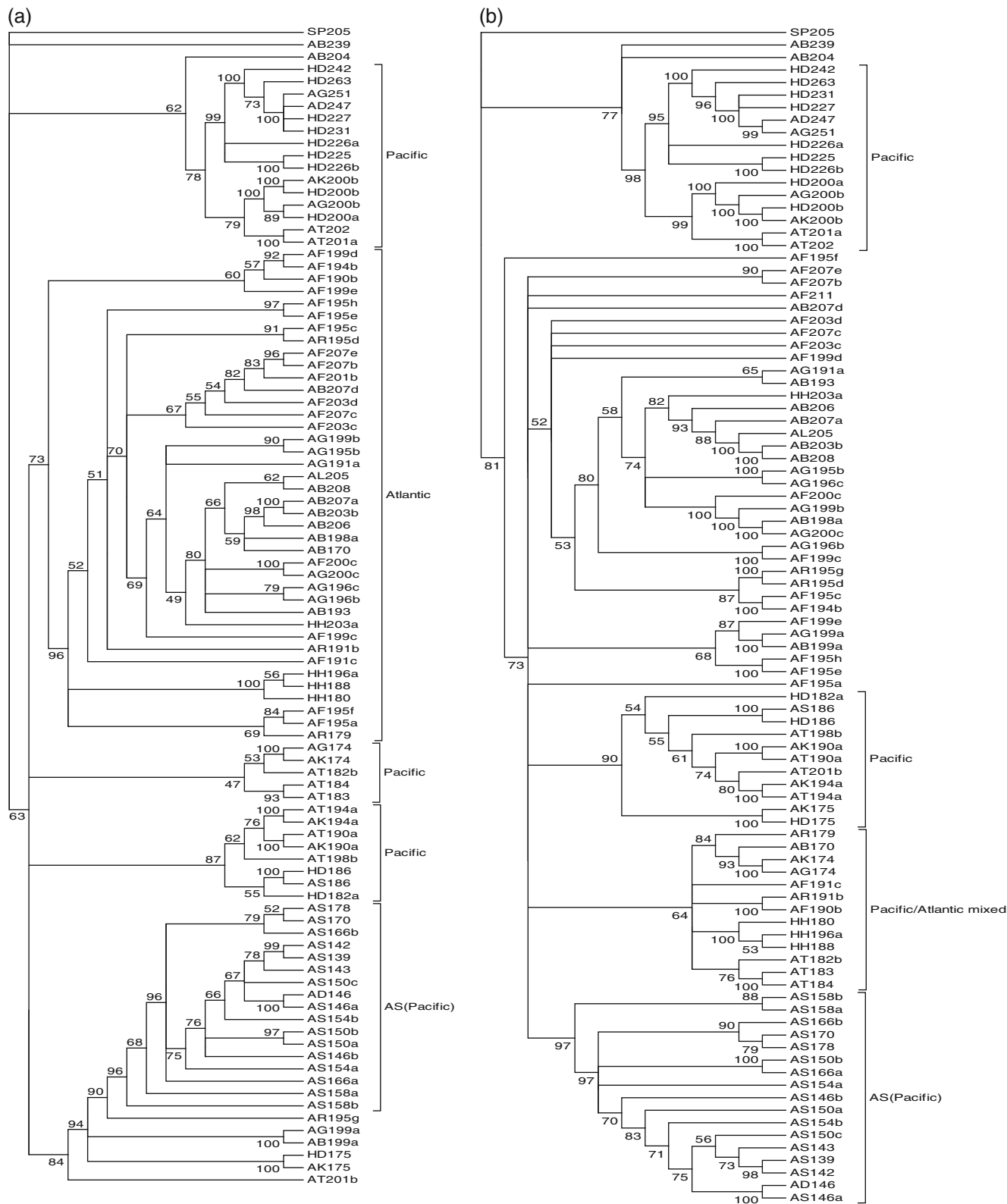

**Figure 3.** Neighbour-joining trees based on repeat region. (A) Tree I based on repeat region with repeat-like (RL) region. (B) Tree II based on repeat region only. The pairwise molecular divergence among homologous was estimated by aligning their tandem repeat sequences using the MS-Align program (Bérard and Rivals 2003). The tree was inferred with FastME (Desper and Gascuel 2002) from the matrix of pairwise alignment distances. For each internal edge, the confidence value (between 0 and 1) and the rate of elementary well-designed quartets (Re) were computed (Guenoche and Garreta 2000). The abbreviations of the species names are given in table 1.

Pacific group		Atlantic group	
SP205	<u>OKOLLLLLLLLLL</u> -----	SP205	<u>OKOLLLLLLLLLL</u> -----
	<b>Type I</b>		<b>Type I</b>
HD263	<u>OKOLLLLLLLLLLLLLLLLLLLLLLLLLLN-OKOKOO</u>	AB239	<u>UKOLLLLLLLLLLLLLLLLLLLLLLLOOOOO</u>
<u>AG251</u>	<u>OKO-----LLLLLLLLLLLLLLLLLLLLLNOOKOKOO</u>	AB204	<u>UK-----LLLLCLLDLLLLLLLLLLOX---</u>
AD247	<u>OKO-----LLLLLLLLLLLLLLLLLLLLLNOOKOKOO</u>		<b>Type II</b>
HD231	<u>OKO-----LLLLLLLLLLLLLLLLLLLLLN--OOKOO</u>	AF211	<u>UKO---LLLLLLLLLOOOOOOOOOO----</u>
HD227	<u>OKO-----LLLLLLLLLLLLLLLLLLLLLN--OOKOO</u>	AF207e	<u>UKO---LLLLLLLLLOOOOOOOOOO----</u>
HD242	<u>OKO---LLLLLLLLLLLLLLLLLLLLL--OOKOO</u>	AF207b	<u>UKO---LLLLYLOOOOOOOOOO----</u>
HD225	<u>OKO-----LLLLLLLLLLLLLLLLL-OOOKOO</u>	AF195f	<u>UKO---LLLLLLLLLOOOOOOOO----</u>
HD226b	<u>OKO-----LLLLLLLLLLLLLLLLL-OOOKOO</u>	AF195a	<u>UKO---OLLLLLLOOOOOO-----</u>
HD226a	<u>OKO-----LLLLLLLLLLLLLLOL-OOOKOO</u>	AB207d	<u>UKO---LLLLLLLLLOOOOOOOOOO----</u>
<u>AG200b</u>	<u>-----LLDLLLLLLLLL--OOKOO</u>	AF207c	<u>UKO---LLLLLLLLLOOOOOOOOOO----</u>
HD200b	<u>-----LLDLLLLLLLLL--OOKOO</u>	AF203d	<u>UKO---LLLLLLLLLOOOOOOOOOO----</u>
AK200b	<u>-----LLDLLLLLLLLL--OOKOO</u>	AF199e	<u>UKO---LLLLLLLLLOOOOOOOOOO----</u>
HD200a	<u>-----LLDLLLLLLLLL--OOKOO</u>	AG199a	<u>UOO-----LLLLLOOOSOOOOO----</u>
AT201a	<u>OF-----LLLLDLDLDDL--OOKOO</u>	AB199a	<u>UOO-----LLLLLOOOSOOOOO----</u>
AT202	<u>OK-----LLLLDLDLDDL--OOKOO</u>	AF203c	<u>UKO-----LLLLLOOOOOOOOOO----</u>
	<b>Type II</b>	HH203a	<u>UKO-----LLLLLOOOOOOOOOOWO----</u>
AT198b	<u>OKO-----LLOLLOOOOOOOJJ-----</u>	AF199d	<u>UKO-----LLLLLOOOOOOOOOO----</u>
AK175	<u>U-O-----LLOLLOOOO-----</u>	AF191c	<u>UKO-----LLLLLOOOOOOOO----</u>
HD175	<u>U-O-----LLOLLOOOO-----</u>	AF195h	<u>LIO-----LLLLLOOOOOOOOOO----</u>
AT201b	<u>OF-----LLOL-LOOOOOOOOOO----</u>	AF195e	<u>UKO-----LLLLLOOOOOOOOOO----</u>
AK194a	<u>OKO-----LLOL-OOOOOOOOO----</u>	AR195g	<u>OUO-----LLLXOOOOOOOOO----</u>
AT194a	<u>OKO-----LLOL-OOOOOOOOO----</u>	AR195d	<u>UKO-----LLLXOOOOOOOOO----</u>
AK190a	<u>OKO-----LLOL-OOOOOOOOO----</u>	AG196b	<u>UI-----LLLLOOOOOOOOOOOO----</u>
AT190a	<u>OKO-----LLOL-OOOOOOOOO----</u>	AF199c	<u>UKO-----LLLLOOOOOOOOOOOO----</u>
AS186	<u>OKO-----LLOL-OOOOOOO-----</u>	AF195c	<u>UKO-----LLLLOOOOOOOOOOOO----</u>
HD186	<u>OKO-----LLOL-OOOOOOO-----</u>	<b>AF194b</b>	<b>OKO-----LLLLOOOOOOOOOOOO----</b>
HD182a	<u>OKO-----LLOL-OOOOOOO-----</u>	AR191b	<u>UKO-----LLLLOOOOOOOOOOOO----</u>
AT182b	<u>OKO-----LLOLOOOOOO-----</u>	AF190b	<u>UKO-----LLLLOOOOOOOOOO----</u>
<u>AG174</u>	<u>OKO-----LLOLOOOOOO-----</u>	AR179	<u>UKO-----LLLLOOOOOO-----</u>
AK174	<u>OKO-----LLOLOOOOOO-----</u>	HH180	<u>UKO-----LMLOOOOOOO-----</u>
AT183	<u>OKO-----LLOLOOOOOUO-----</u>	HH196a	<u>UKO-----LMLOOOOOOOOOOO----</u>
AT184	<u>OKO-----LLOLOOOOOUO-----</u>	HH188	<u>UKO-----LMLOOOOOOOOO-----</u>
	<b>Type III</b>	AB206	<u>UIB-----LLOOOOOOOOOOVOVOWO</u>
AS158b	<u>-----OPOOXOOOOO-----</u>	AB207a	<u>UIB-----LLOOOOOOOOOOUVOWO</u>
AS158a	<u>-----OOOOOOOOOO-----</u>	AB203b	<u>UIB-----LLOOOOOOOOOO-UVOWO</u>
AS146b	<u>-----OOOOOOOJ-----</u>	AB208	<u>UKO-----LLOOOOOOOOOO-UVOWO</u>
AS154a	<u>-----OOOOOOOJJ-----</u>	AL205	<u>UIO-----LLOOOOOOOOOO-UVOWO</u>
AS150a	<u>-----OOOOOOOJJ-----</u>	AB198a	<u>UIB-----LLOOOOOOOOOOOOOO----</u>
AD146	<u>-----OOOOOJJ-----</u>	AG200c	<u>UIO-----LLOOOOOOOOOOOOOO----</u>
AS146a	<u>-----OOOOOJJ-----</u>	AG199b	<u>UKO-----LLOOOOOOOOOOOOOO----</u>
AS142	<u>-----OOOOJJ-----</u>	AF200c	<u>UIO-----LLOOOOOOOOOOOOOO----</u>
AS143	<u>-----OOOJJ-----</u>	AG195b	<u>UKO-----LLOOOOOOOOOOOOOO----</u>
AS139	<u>-----OOJJ-----</u>	AG196c	<u>UKO-----LLOOOOOOOOOOOOOO----</u>
AS166a	<u>-----OOOOOOOROOJJ-----</u>	AG191a	<u>UKO-----LLOOOOOOOOOOOO----</u>
AS150b	<u>-----OOOROOJJ-----</u>	AB170	<u>UIB-----LLOOOOOO-----</u>
AS166b	<u>-----OOOOOOOOOJJJ-----</u>	AB193	<u>UEO-----ZYOWOWOOOOO----</u>
AS154b	<u>-----OOOOOOOJJJ-----</u>		
AS178	<u>-----OOOOOOOOOJJJJ-----</u>		
AS170	<u>-----OOOOOOOOOJJJJ-----</u>		
AS150c	<u>-----OOOLJJJJ-----</u>		
<b>O = TAAA</b>	<b>L = TAGA</b>	<b>X = TAAG</b>	<b>N = TAGGA</b>
<b>K = AAAA</b>	<b>J = GAAA</b>	<b>Y = TAGC</b>	<b>M = TAAGA</b>
<b>F = AAA</b>	<b>V = TATA</b>	<b>Z = CAGT</b>	<b>D = GA</b>
<b>U = TAAAA</b>	<b>R = TTAA</b>	<b>P = CAAA</b>	<b>B = TA</b>
<b>I = AAAAA</b>	<b>W = TAAT</b>	<b>S = TACA</b>	
<b>E = AAAAT</b>			

Figure 4. Encoding map of repeat and repeat-like (RL) region. The RL regions are underlined. The four exceptional sequences of Atlantic species, three AG and one AF are in bold font (see text). The different repeat types are divided and indicated by types I, II and III.

figure 4. Almost all sequences from Atlantic species contain repeat type II, except for two sequences from *A. baerii*, which shows repeat type I. However, in Pacific group column, each species displays two repeat types. *A. schrenckii*, *Huso dauricus* and *A. transmontanus* contain repeat types I and II, and the sequence quantity of each repeat type is similar. *A. dabryanus* and *A. sinensis* mainly include repeat type III with two exceptional sequences, AD247 and AS186, which have repeat type I and type II, respectively. It should be mentioned that in one individual of the diploid species *H. dauricus*, we found four alleles (it was a surprise, probably due to paralogy following a local duplication), HD242, 200, 186 and 182a, in which the two larger alleles have repeat type I and flanking haplotype T1-4, while the two smaller ones have repeat type II and flanking haplotype T1-19 (figures 1 and 4). Moreover, in *A. sinensis* and *A. dabryanus*, AS186 (in type II) and AD247 (in type I) differ from the other alleles of the same species, both in flanking sequence and repeat structure (see figures 1 and 4). Allele AS186 coexists with the other four alleles (in type III) in one individual of *A. sinensis*, which has been reported as a tetraploidy species.

### Discussion

The flanking region of locus *Spl-106*, which is originally isolated from *S. platyrhynchus* by McQuown *et al.* (2000), was highly conserved among the species of genera *Acipenser*, *Huso* and *Scaphirhynchus*, which diverged about 150 million years ago (Mya) (Peng *et al.* 2007). The failed amplification of the homologous sequences in *A. sturio* and *P. spathula* is probably due to mutations occurring at the primers sites.

Long time of microsatellite loci stability have been observed in some other species, e.g., over 300 My in turtles (FitzSimmons *et al.* 1995) and over 450 My in fish species (Rico *et al.* 1996). Flanking region stability on long time diverged taxa is necessity to study microsatellite evolution and to resolve the phylogenetic relationships of lineages. However, only a distorted sight is expected since we did not analyse the allele sequences at different steps of their evolution, but rather the present sequences which were influenced by very ancient speciation and splitting events.

#### Flanking region evolution

Concerning the flanking region of microsatellites, the rate of sequence divergence has been estimated in some fish groups: from 0.02% to 0.05% per My among diverse fish species (Rico *et al.* 1996), and between 0.14%–0.83% in sunfish (Neff *et al.* 1999). Our estimation on the microsatellite locus *Spl-106* in sturgeons is between 0.011% and 0.079% with an average at 0.028% per My, which is similar to that estimated by Rico *et al.* (1996). However, it is slightly lower than that of satellite DNA in sturgeons (0.07% per My for *HindIII* and 0.11% per My for *PstI*; Robles *et al.* 2004).

The slow rate of molecular evolution in Acipenseriformes had been demonstrated in satellite loci (*HindIII* and *PstI*)

and mitochondrial loci (De la Herrán *et al.* 2001; Krieger and Fuerst 2002; Robles *et al.* 2004). Also, this general observation is now supported by our data set of microsatellite sequences. According to Neff *et al.* (1999), the rate of sequence divergence at the microsatellite flanking regions may be dependent on the locus itself. However, according to several observations, the slow rate of sequence divergence seems to be the general rule of microsatellite evolution in this ancient fish group, Acipenseriformes: (i) among the 108 loci screened in *S. platyrhynchus*, 65%–80% can be successfully amplified on *Acipenser* species (McQuown *et al.* 2000); (ii) the microsatellite loci originally screened in the American paddlefish *P. spathula* can be crossamplified on most species of the family Acipenseridae (Heist *et al.* 2002). This apparently easy cross-priming should be the mark of a general slow mutation rate.

#### Repeat region evolution and paralogy

According to the diversified repeat structures, the evolutionary process of *Spl-106* is more complicated in the Pacific than in the Atlantic lineage. In the Atlantic lineage, slippage duplication is the main mechanism in the evolutionary process, and the repeat number changes among the two basic repeat units contribute a lot to the size homoplasy. However, in Pacific group, each species contains generally two types of repeat structures corresponding to two evolutionary routes.

It is improbable that the different repeat types found in the same species could be due to stepwise mutation model. The same flanking sequence with different repeat motifs should be an evidence of paralogy (Karhu *et al.* 2000). Here, several point mutations and indels also occurred on the flanking sequences, which indicate that the two paralogs have been evolving independently for a long time. According to the distribution of the three repeat types on species (figure 4), two duplication events encompassing the locus *Spl-106* probably occurred during the divergence of Pacific lineage: the first occurred before the diversification of Pacific species (121–96 Mya) and led to repeat types I and II; the second occurred more recently, just before the speciation of *A. sinensis* and *A. dabryanus* (69–10 Mya) and led to repeat type III. Therefore, the sequences in the same species with different repeat types likely are paralogous loci. Paralogs are genes that derive from a single gene that was duplicated within a genome. This could also explain the phenomenon that four alleles, among which two contain repeat type I and the other two contain repeat type II, were present in one individual of the diploid species *H. dauricus*, and that five alleles, among which one has repeat type II, while the other four alleles have repeat type III, were detected in one individual of the tetraploid species *A. sinensis*.

#### Evolutionary relationships of flanking and repeat regions

Our results show a synchronous evolutionary pattern between flanking and repeat regions. Homologous sequences

with different repeat types may have the same flanking sequences, but homologous sequences with different flanking haplotypes normally have different repeat structures. Especially, in the sequences of clade AS–AD (group 3; figure 2), the large variation due to 11-bp deletion in the flanking region is consistent with the great change in repeat structure (see AS and AD alleles in figure 4). Microsatellite loci are as vulnerable as the rest of the genome to point mutations, whose effect is to divide long repeat stretches into smaller subunits, and hence decrease the rate at which slippage occurs (Bell and Jurka 1997; Kruglyak et al. 1998). Without the effects of the slippage mutation, the rates of base substitution or indels should be similar between the flanking and repeat regions. Moreover, both flanking and repeat regions (including the RL region) support the splitting of Pacific and Atlantic lineages, and the homologous sequences evolved independently after this split.

#### Adequacy with sturgeon phylogeny

The phylogenetic relationships of Acipenseriformes have been extensively studied by morphological characters and mitochondrial genes; however, many issues remain unresolved (Artyukhin 2006; Peng et al. 2007; Krieger et al. 2008). Several nuclear genes, e.g. *Sox* genes, 5S rDNA and 18S rDNA, have also been used, and did not contradict the consensus phylogeny (Krieger and Fuerst 2002; Hett and Ludwig 2005). For instance, the *PstI* satellite sequence supported the observed Atlantic/Pacific split and *HindIII* satellite sequence supported the basal position of both *A. sturio* and *A. oxyrinchus* (Robles et al. 2004).

In our data set, the flanking regions of microsatellite locus *Spl-106* are highly conserved at the subfamily level: among the genera *Scaphirhynchus*, *Huso* and most species of genus *Acipenser*, except for *A. sturio*, in which no homologous sequence of locus *Spl-106* was detected by the same primer set. It confirms that *A. sturio* diverged earlier than *Scaphirhynchus* in the phylogeny of Acipenseriformes. The failed amplifications in *A. naccarii* and *Psephurus gladius* were probably due to the quality of the DNA extracted from limited sample material. We could not conclude that this locus was absent from *A. naccarii*, which is very close to *A. gueldenstaedtii* and *A. baerii* in all sturgeon phylogenies. However, it is possible that this locus does not exist in the paddlefish, *Psephurus gladius*, since we also did not find it in the other paddlefish, *Polyodon spathula*, allowing us to estimate the birth of this locus at about 185 Mya, during the early Jurassic (Peng et al. 2007).

The Atlantic and Pacific clades were previously suggested by Ludwig et al. (2001) using cytochrome-*b* DNA sequences and confirmed by Peng et al. (2007). In our results, both the flanking and the repeat regions follow the two geographical lineages. Our sequences are also influenced by the close relationships between (i) *A. sinensis* and *A. dabryanus*; (ii) *A. schrenckii*, *A. transmontanus* and *H. dauricus* (i.e. the Pacific clade); (iii) *A. fulvescens*, *A. ruthenus*, *A. baerii*,

*A. gueldenstaedtii* and *A. stellatus*, which have been supported by the other molecular evidence (Krieger et al. 2008). Our results indicate that the evolution of a given microsatellite locus is directly driven by the speciation history revealed by mtDNA sequences, but does not follow the morphological and taxonomic considerations (Artyukhin 2006). The two *Huso* species clearly belong to the genus *Acipenser* and are separately assigned to Pacific and Atlantic lineages. Although the flanking sequence is not variable enough for reflecting the phylogenetic relationships among all sturgeon species, we still found several specific diagnostic sites from the closely related species pair, *A. sinensis* and *A. dabryanus* (group 3 in figures 1 and 2), and the lake sturgeon *A. fulvescens* (group 2 in figures 1 and 2).

#### Acknowledgements

The authors would like to thank the members of the Wuhan laboratory for their assistance in this research. We also want to thank Prof. Brigitte Crouau-Roy for her helpful discussions on the manuscripts, to Marie-Claire Mella for proofreading. This work was supported by the Key Project of Chinese Academy of Sciences (grant number KSCX2-1-03); Executive Office of the State Council Three Gorges Project Construction Committee of China (grant number SX2003-008); and the Chinese–French Advanced Research Programme (grant number PRA-E 02/03). ZJS was supported by the French Research Ministry post-doctoral grants, the National Natural Science Foundation of China (grant number NSFC 30490234), and a post-doctoral grant from the University Montpellier II. ER was supported by a grant from the Action Concertée Incitative IMPBio ‘Repevol’, by grant ANR blanche (CoCoGen project) (BLAN07-1\_185484) from the French National Research Agency.

#### References

- Artyukhin E. N. 2006 Morphological phylogeny of the order Acipenseriformes. *J. Appl. Ichthyol.* **22**, 66–69.
- Bell G. I. and Jurka J. 1997 The length distribution of perfect dimer repetitive DNA is consistent with its evolution by an unbiased single-step mutation process. *J. Mol. Evol.* **44**, 414–421.
- Bérard S. and Rivals E. 2003 Comparison of minisatellites. *J. Comput. Biol.* **10**, 357–372.
- Bérard S., Nicolas F., Buard J., Gascuel O. and Rivals E. 2006 A fast and specific alignment method for minisatellite maps. *Evol. Bioinform.* **2**, 303–320.
- Bonhomme F., Rivals E., Orth A., Grant G. R., Jeffreys A. J. and Bois P. R. J. 2007 Species-wide distribution of highly polymorphic minisatellite markers suggests past and present genetic exchanges among house mouse subspecies. *Genome Biol.* **8**, R80.
- Brohede J. and Ellegren H. 1999 Microsatellite evolution: polarity of substitutions within repeats and neutrality of flanking sequences. *Proc. R. Soc. London B* **266**, 825–833.
- Chirhart S. E., Honeycutt R. L. and Greenbaum I. F. 2005 Microsatellite variation and evolution in the *Peromyscus maniculatus* species group. *Mol. Phylog. Evol.* **34**, 408–415.
- Comincini S., Lanfredi M., Rossi R. and Fontana F. 1998 Use of RAPD markers to determine the genetic relationships among sturgeons (Acipenseridae, Pisces). *Fish. Sci.* **64**, 36–39.
- Crow J. F. and Kimura M. 1970 *An introduction to population genetics theory*, pp. 591. Harper and Row, New York, USA.
- De la Herrán R., Fontana F., Lanfredi M., Confu L., Leis M., Rossi R. et al. 2001 Slow rates of evolution and sequence

- homogenization in an ancient satellite DNA family of sturgeons. *Mol. Biol. Evol.* **18**, 432–436.
- Dereeper A., Guignon V., Blanc G., Audic S., Buffet S., Chevenet F. *et al.* 2008 Robust phylogenetic analysis for the non-specialist. *Nucleic Acids Res.* **36** (suppl. 2), W465–W469.
- Desper R. and Gascuel O. 2002 Fast and accurate phylogeny reconstruction algorithms based on the minimum-evolution principle. *J. Comput. Biol.* **9**, 687–705.
- Di Rienzo A., Peterson A. C., Garza J. C., Valdes A. M., Slatkin M. and Freimer N. B. 1994 Mutational processes of simple-sequence repeat loci in human populations. *Proc. Natl. Acad. Sci. USA* **91**, 3166–3170.
- Estoup A., Jarne P. and Cornuet J. M. 2002 Homoplasy and mutation model at microsatellite loci and their consequences for population genetics analysis. *Mol. Ecol.* **11**, 1591–1604.
- FitzSimmons N. N., Moritz C. and Moore S. S. 1995 Conservation and dynamics of microsatellite loci over 300 million years of marine turtle evolution. *Mol. Biol. Evol.* **12**, 432–440.
- Goldstein D. B. and Schlötterer C. 1999 *Microsatellites: evolution and applications*, pp. 352. Oxford University Press, New York, USA.
- Guenoche A. and Garreta H. 2000 Can we have confidence in a tree representation? In Proceedings of the First International Conference on Biology, Informatics, and Mathematics: 2000 May 3–5, Montpellier. (ed. O. Gascuel and M. F. Sagot), pp. 45–56. (Lecture Notes in Computer Science 2066), Springer-Verlag, Berlin.
- Guindon S. and Gascuel O. 2003 A simple, fast, and accurate algorithm to estimate large phylogenies by maximum likelihood. *Syst. Biol.* **52**, 696–704.
- Heist E. J., Nicholson E. H., Sipoorski J. T. and Keeney D. B. 2002 Microsatellite markers for the paddlefish (*Polyodon spathula*). *Conserv. Genet.* **3**, 205–207.
- Hett A. K. and Ludwig A. 2005 SRY-related (Sox) genes in the genome of European Atlantic sturgeon (*Acipenser sturio*). *Genome* **48**, 181–186.
- Karhu A., Dieterich J. H. and Savolainen O. 2000 Rapid expansion of microsatellite sequences in pines. *Mol. Biol. Evol.* **17**, 259–265.
- Kimura M. and Crow J. F. 1964 The number of alleles that can be maintained in a finite population. *Genetics* **49**, 725–738.
- Kimura M. and Ohta T. 1978 Stepwise mutation model and distribution of allelic frequencies in a finite population. *Proc. Natl. Acad. Sci. USA* **75**, 2868–2872.
- Krieger J. and Fuerst P. A. 2002 Evidence for a slowed rate of molecular evolution in the order Acipenseriformes. *Mol. Biol. Evol.* **19**, 891–897.
- Krieger J., Hett A. K., Fuerst P. A., Artyukhin E. and Ludwig A. 2008 The molecular phylogeny of the order Acipenseriformes revisited. *J. Appl. Ichthyol.* **24**, 36–45.
- Kruglyak S., Durrett R. T., Schug M. D. and Aquadro C. F. 1998 Equilibrium distributions of microsatellite repeat length resulting from a balance between slippage events and point mutations. *Proc. Natl. Acad. Sci.* **95**, 10774–10778.
- Leclercq S., Rivals E. and Jarne P. 2010 DNA slippage occurs at microsatellite loci without minimal threshold length in humans: a comparative genomic approach. *Genome Biol. Evol.* **2**, 325–335.
- Levinson G. and Gutman G. A. 1987 Slipped-strand mispairing: a major mechanism for DNA sequence evolution. *Mol. Biol. Evol.* **4**, 203–221.
- Li J., Macaubas C., Hallmayer J., Kimura A. and Mignot E. 1996 Mutation rate varies among alleles at a microsatellite locus: Phylogenetic evidence. *Proc. Natl. Acad. Sci.* **93**, 15285–15288.
- Ludwig A., Belfiore N. M., Pitra C., Svirsky V. and Jenneckens I. 2001 Genome duplication events and functional reduction of ploidy levels in sturgeon (*Acipenser*, *Huso* and *Scaphirhynchus*). *Genetics* **158**, 1203–1215.
- Makova K. D., Nekrutenko A. and Baker R. J. 2000 Evolution of microsatellite alleles in four species of mice (Genus *Apodemus*). *J. Mol. Evol.* **51**, 166–172.
- McQuown E. C., Sloss B. L., Sheehan R. J., Rodzen J., Tranah G. J. and May B. 2000 Microsatellite analysis of genetic variation in sturgeon (*Acipenseridae*): new primer sequences for *Scaphirhynchus* and *Acipenser*. *Trans. Am. Fish. Soc.* **129**, 1380–1388.
- Messier W., Li S. and Stewart C. 1996 The birth of microsatellite. *Nature* **381**, 483.
- Neff B. D., Fu P. and Gross M. R. 1999 Microsatellite evolution in sunfish (Centrarchidae). *Can. J. Fish. Aquat. Sci.* **56**, 1198–1205.
- Ortí G., Pears D. E. and Avise J. C. 1997 The effect of marker heterozygosity on the power to detect linkage disequilibrium. *Genetics* **147**, 927–930.
- Peng Z., Ludwig A., Wang D., Diogo R., Wei Q. and He S. 2007 Age and biogeography of major clades in sturgeons and paddlefishes (Pisces: Acipenseriformes). *Mol. Phylog. Evol.* **42**, 854–862.
- Rico C., Rico I. and Hewitt G. 1996 470 million years of conservation of microsatellite loci among fish species. *Proc. R. Soc. London B* **263**, 549–557.
- Robles F., De la Herrán R., Ludwig A., Ruiz Rejón C., Ruiz Rejón M. and Garrido-Ramos M. A. 2004 Evolution of ancient satellite DNAs in sturgeon genomes. *Gene* **338**, 133–142.
- Robles F., De la Herrán R., Ludwig A., Ruiz Rejón C., Ruiz Rejón M. and Garrido-Ramos M. A. 2005 Genomic organization and evolution of the 5S ribosomal DNA in the ancient fish sturgeon. *Genome* **48**, 18–28.
- Shao Z. J., Zhao N., Zhu B., Zhou F. L. and Chang J. B. 2002 Applicability of microsatellite primers developed from shovel-nose sturgeon in Chinese sturgeon. *Acta. Hydrobiol.* **26**, 577–584. (in Chinese with English abstract).
- Shao Z. J., Lek S. and Chang J. 2005 Complex mutation at a microsatellite locus in sturgeons: *Acipenser sinensis*, *A. schrenckii*, *A. gueldenstaedtii* and *A. baerii*. *J. Appl. Ichthyol.* **21**, 2–6.
- Tamura K., Dudley J., Nei M. and Kumar S. 2007 MEGA4: Molecular evolutionary genetics analysis (MEGA) software version 4.0. *Mol. Biol. Evol.* **24**, 1596–1599.
- Taylor J. S., Durkin J. M. H. and Breden F. 1999a The death of a microsatellite: a phylogenetic perspective on microsatellite interruptions. *Mol. Biol. Evol.* **16**, 567–572.
- Thompson J. D., Gibson T. J., Plewniak F., Jeanmougin F. and Higgins D. G. 1997 The clustal x windows interface: flexible strategies for multiple sequence alignment aided by quality analysis tools. *Nucleic Acids Res.* **24**, 4876–4882.
- Zardoya R., Vollmer D. M., Craddock C., Streebman J. T., Karl S. and Meyer A. 1996 Evolutionary conservation of microsatellite flanking regions and their use in resolving the phylogeny of cichlid fishes (Pisces: Perciformes). *Proc. R. Soc. London B* **263**, 1589–1598.
- Zhu Y., Queller D. C. and Strassmann J. E. 2000 A phylogenetic perspective on sequence evolution in microsatellite loci. *J. Mol. Evol.* **50**, 324–338.

Received 18 April 2010, in revised form 7 November 2010; accepted 29 December 2010  
 Published on the Web: 19 August 2011