



HAL
open science

TOETS: Work Package 1

Philippe Cauvet, Olivier Potin, Marie-Lise Flottes, Serge Bernard, David Andreu, Ziad Noun

► **To cite this version:**

Philippe Cauvet, Olivier Potin, Marie-Lise Flottes, Serge Bernard, David Andreu, et al.. TOETS: Work Package 1. The European Nanoelectronics Forum 2011, Nov 2011, Dublin, Ireland. , 2011. lirmm-00653039

HAL Id: lirmm-00653039

<https://hal-lirmm.ccsd.cnrs.fr/lirmm-00653039>

Submitted on 16 Dec 2011

HAL is a multi-disciplinary open access archive for the deposit and dissemination of scientific research documents, whether they are published or not. The documents may come from teaching and research institutions in France or abroad, or from public or private research centers.

L'archive ouverte pluridisciplinaire **HAL**, est destinée au dépôt et à la diffusion de documents scientifiques de niveau recherche, publiés ou non, émanant des établissements d'enseignement et de recherche français ou étrangers, des laboratoires publics ou privés.



Goal: Transform Test features into product Differentiators



Enhance Access and Control
Self-repair solutions
Self-calibration functions

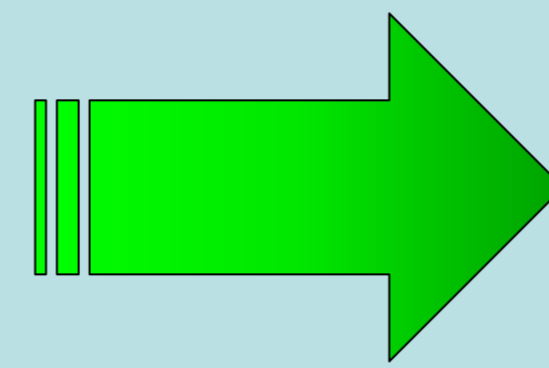

To the integrators
To end-users

Major Achievement: Wireless Test Access *

**SiP-SoC
Production
Test**



▪ **Specific MAC layer: low power, minimal area overhead, reliability**

- ✓ Embedded Wireless Test Control Block (WTCB)
- ✓ Test management at circuit level
- ✓ Generic test access

▪ **Adaptive Test Response Handling**

- ✓ Centralized Comparison on ATE for full diagnostic
- ✓ Distributed Comparison on DUTs for test time reduction

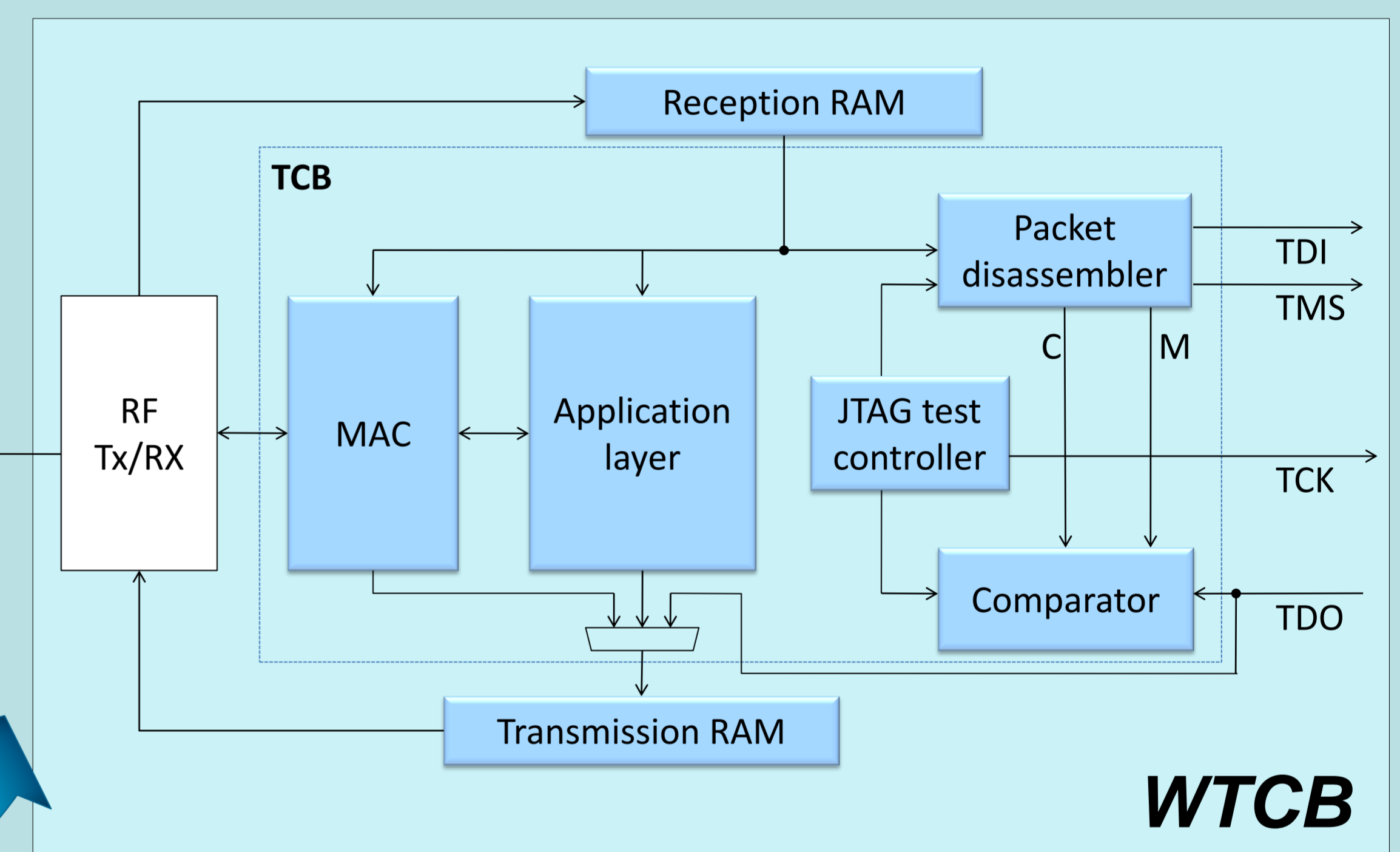

▪ **Massive parallel test**

➔ Test time reduction by 4-5

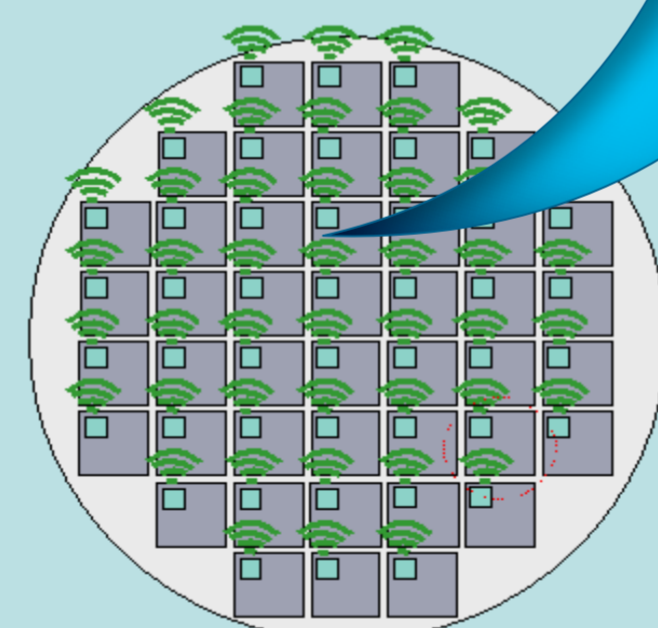

**In-Situ
Test**

▪ **In Situ/On-line Tests & Diagnostics**

- ✓ Easy maintenance
- ✓ Low cost diagnosis

▪ **Switch**

- ✓ Reuse native wireless frontend
- ✓ Minimal area overhead

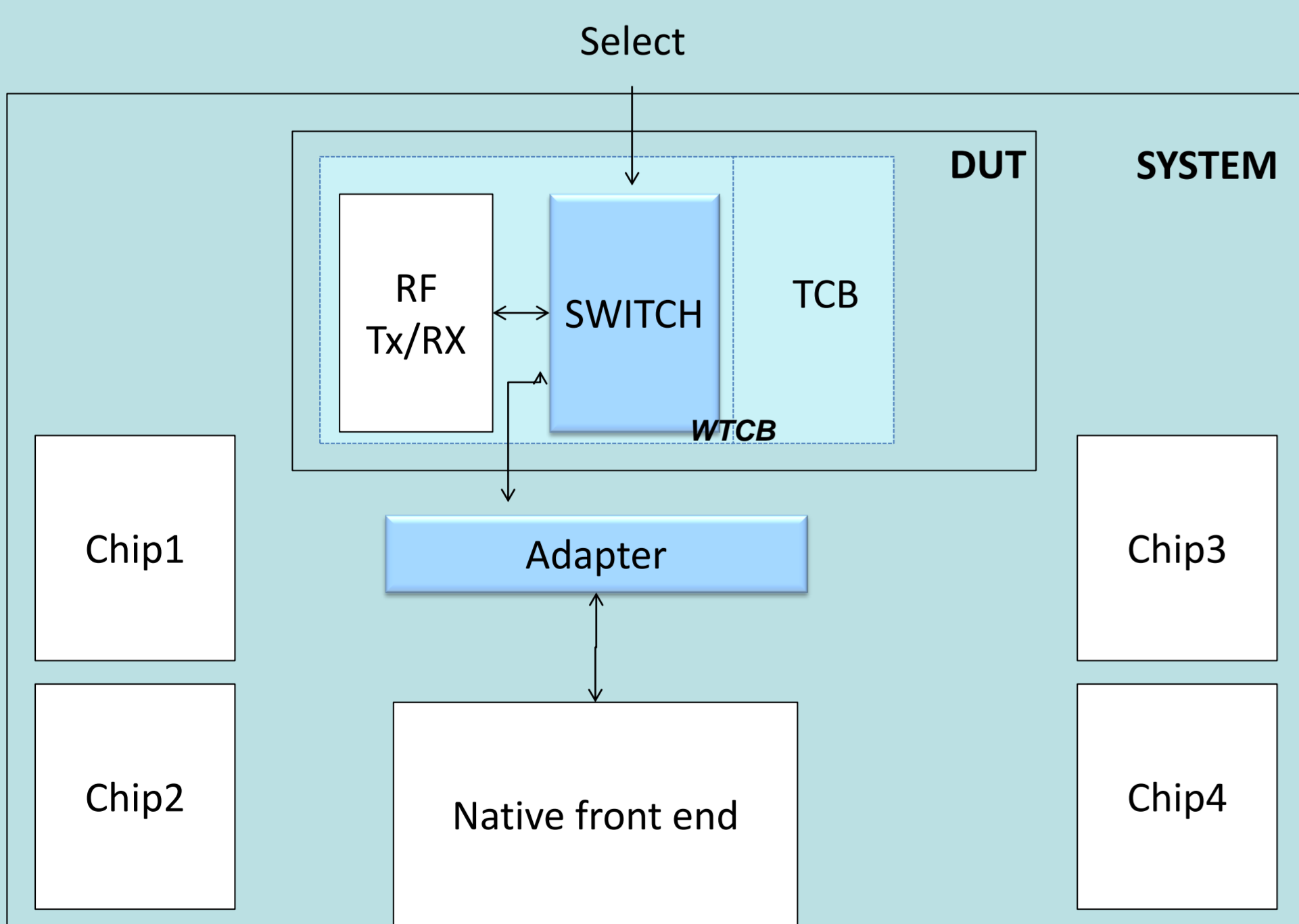
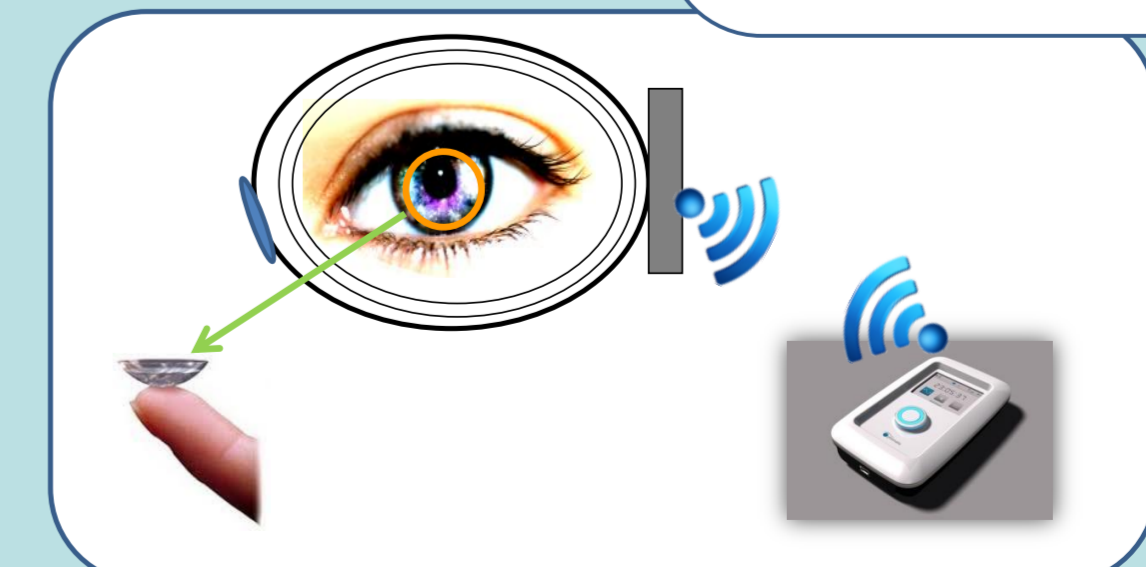

* Works conducted by LIRMM and Optimalia