

Electrical Performances of a New Multipolar Micro-Stimulator

Jean-Denis Techer, Guy Cathébras, Yves Bertrand, David Guiraud, Serge
Bernard

► **To cite this version:**

Jean-Denis Techer, Guy Cathébras, Yves Bertrand, David Guiraud, Serge Bernard. Electrical Performances of a New Multipolar Micro-Stimulator. IFESS: International Functional Electrical Stimulation Society, Jul 2005, Montréal, Canada. IFESS'05: 10th Annual Conference of the International Functional Electrical Stimulation Society, pp.232-234, 2005. <lirmm-00106475>

HAL Id: lirmm-00106475

<https://hal-lirmm.ccsd.cnrs.fr/lirmm-00106475>

Submitted on 16 Oct 2006

HAL is a multi-disciplinary open access archive for the deposit and dissemination of scientific research documents, whether they are published or not. The documents may come from teaching and research institutions in France or abroad, or from public or private research centers.

L'archive ouverte pluridisciplinaire **HAL**, est destinée au dépôt et à la diffusion de documents scientifiques de niveau recherche, publiés ou non, émanant des établissements d'enseignement et de recherche français ou étrangers, des laboratoires publics ou privés.

Electrical Performances of a New Multipolar Micro-Stimulator

S. Bernard, J. D. Techer, G. Cathébras, Y. Bertrand and D. Guiraud

LIRMM / CNRS / INRIA / University of Montpellier / DEMAR Project,
161 rue Ada, 34392 Montpellier, France

bernard@lirmm.fr

Abstract

A large number of applications exist for Multipolar stimulation. But the main difficulty for this kind of stimulation is the stimulator which has to be able to generate accurate stimulation current and to share this current between the different cathodes. In this paper we propose an electrical evaluation of the micro-stimulator we have developed. To do this, we have conducted several experiments on physiological solution to evaluate the linearity and the sharing stability of the generated current according to a large range of stimulation current.

1. INTRODUCTION

Since the early 80's, multiple implanted Functional Electrical Stimulation (FES) devices have been developed and tested, and for some transferred into clinical practice [1-7]. These devices, which are destined to restore motor functions in spinal cord injured (SCI) patients, are based on the same principle: the activation of neuromotor fibres by an electrical stimulus. However, in order to achieve different recruitment modes such as afferent blocking or fibre-type discrimination, different electrode geometries with different numbers of poles have been studied, with adapted stimulus waveforms and pulse patterns ([8], [9]). We propose a new architecture to support such complex advanced stimulation schemes.

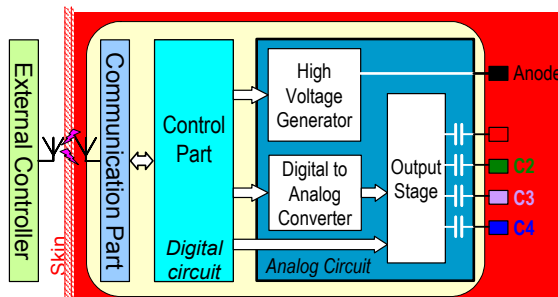

Figure 1. Implanted micro-stimulator

2. METHODS

The implantable stimulator we propose (figure 1) is composed of three parts: a communication part to communicate with the external controller, an embedded control unit to manage the low level stimulation phase and an active part to generate the analog stimulation current.

From microelectronic point of view, the most critical part is the active part. It corresponds to a full custom design of an analogue circuit. The analog part architecture is described figure 1. It includes a high voltage source realized with an improved Dickson charge pump, a strictly monotonous Digital-to-Analog Converter and an output stage able to drive the multi-polar electrode.

In this paper we focus on the output stage circuitry. Our objective is to evaluate its accuracy to generate adequate current pulse for multi polar stimulation requirements.

2.1. Evaluation of the Output Stage Performances

The output stage implements three functionalities.

First, its main role consists in mirroring and amplifying the output current of the DAC. We have to evaluate the linearity of this amplification according to the full range of stimulation current amplitude.

Second, the output stage must share out the I0 stimulation current between cathodes in order to activate different parts of the nerve. In practice, we designed this output stage (see figure 2) in such a way that each cathode can be fed by individual current taken among the following set of values { I0; 3I0/4; 2I0/3; I0/2; I0/3; I0/4; 0}. To implement these current ratios, the output transistor is split into 4 groups of 12 elementary transistors, each group being associated to one cathode (see figure 3). The logic control (around 200 gates) has been designed in such a way that exactly 12 transistors are conducting at the same time, thus

allowing us to obtain the 33 possible configurations. The difficulty of multi polar stimulation is to keep the ratio between the current in each cathode independent of the value of the total stimulation current in the anode.

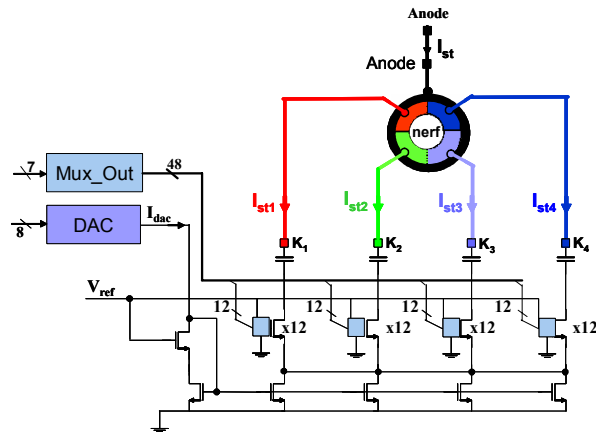

Figure 2. Sharing system of stimulation current between the cathodes.

Third, this output stage has to implement the discharge phase of the stimulation cycle corresponding to the discharge of the safety capacitor C_{safe} . To limit this discharge current to 10% of the max stimulation current, we implemented a design in which we have the opportunity to sequentially add smaller and smaller discharge resistances in parallel. This allows us to progressively lower the time constant while preserving the maximum discharge current (10/10) at each step. We will have to check this by experimentation.

To validate and characterize the different blocks of the stimulator, we realized a test vehicle. In this circuit we have implemented two DACs and two Output Stages. One of each instance is totally controllable and observable allowing a fully independent characterization of each of these functional blocks. The second element permits us to assess the complete stimulator and the influence of each block on the other ones. This test vehicle has been fabricated using the 0.8 μ m High Voltage CXZ technology from AustriaMicroSystems. The silicon area of the ASIC is 4.5 mm x 3.4 mm = 15.3 mm².

2.3 In Vitro Experiment

Our objective is to evaluate the ability of our stimulator to amplify and share stimulation current between the cathodes.

Figure 3 shows our experimental setup.

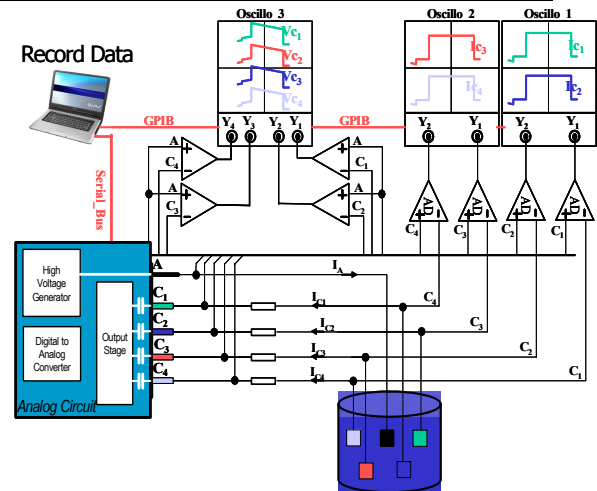

Figure 3. Experimental setup

We use a physiological solution with three bipolar electrodes. One of these electrodes is used as anode and we use the poles of other electrodes as cathode. Then, we use a FPGA (Field Programmable Gate Array) to implement the digital part of the final circuit. This digital part is a micro-machine in charge of the execution of the stimulation sequence [10] allowing us to generate every kind of stimulation currents.

We use three oscilloscopes for the measurements of DAC output current, generated current through the anode and the cathodes and the associated voltages. Thanks to this, we can evaluate the efficiency of our analog circuit in terms of linearity of current amplification and sharing stability of the stimulation current between the cathodes.

3. RESULTS

We have conducted several experiments varying the values of the stimulation current from 0 to 5mA for every kind of cathode sharing possibilities.

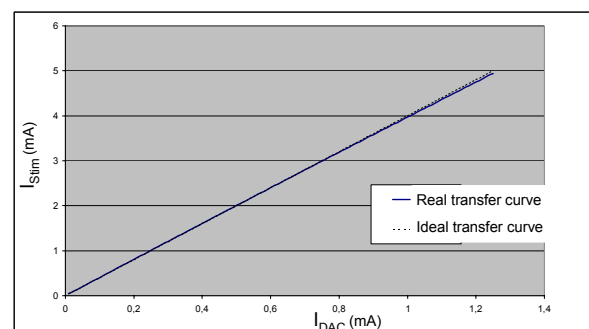

Figure 4. Generated stimulation current vs. DAC output current

3.1 Linearity of Current Amplification

Figure 4 shows the generated current versus the DAC output current in both ideal and real case.

For low stimulation current the amplification is linear but for high stimulation current performances decreases. Nevertheless, in the worst case the amplification error of current from ADC output is as low as 2%. Moreover, it would be possible to compensate this error in the digital domain by the embedded control unit.

3.2 Current Sharing and Safety Discharge

Figure 5 shows the two correlated current pulses available at the Cathode 3 and Cathode 4 ASIC outputs when it is configured for $I_{\text{cathode3}} = I_0/3$ and $I_{\text{cathode4}} = 2 I_0/3$. Similar waveforms are obtained for all the planned configurations.

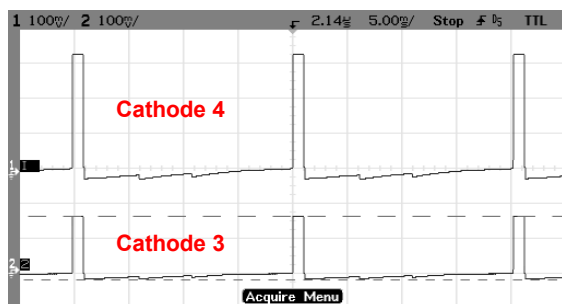

Figure 5. Measurement on two cathodes

From a qualitative observation, the functionality of our stimulator seems to be good. We can verify the properly limited amplitude of the discharge current. In practice, we have measured the current in each electrode according to the total stimulation current in the anode. The worst case is for the largest difference between two cathode currents ($1/4.I_{st}$, $3/4.I_{st}$). But in this case, when we increase the total stimulation current the sharing error is still lower than 3%.

4. DISCUSSION AND CONCLUSIONS

On this paper we have demonstrate that the analog part of our integrated circuit is able to generate precise stimulation current with a non-linearity as low as 2%. Moreover, it is useable for multipolar stimulation with a constant ratio between current in each cathode with an error lower than 3%. Now we have to verify if these results are always true in an in vivo context. Then, we could be able to implant multipolar stimulator for animal experimentations.

5 REFERENCES

- [1] R. Kobetic, R.J. Triolo, J. P. Uhler, C. Bieri, M. Wibowo, G. Polando, E. B. Marsolais, J. A. Davis, "Implanted Functional Electrical Stimulation System for Mobility in Paraplegia: A Follow-Up Case Report", *IEEE Trans. on Rehabilitation Engineering*, vol. 7, no 4, pp 390-398, December 1999.
- [2] B. Smith, Z. Tang, M. W. Johnson, S. Pourmedhi, M. M. Gazdik, J. R. Buckett, P. H. Peckham, "An Externally Powered, Multichannel, Implantable Stimulator-Telemeter for Control of Paralyzed Muscle", *IEEE Trans. On Biomedical Engineering*, vol. 45, no 4, pp 463-475, April 1998.
- [3] G. E. Loeb, R. A. Peck, W. H. Moore, K. Hood, "BIONtm system for distributed neural prosthetic interfaces", *Medical Engineering & Physics*, vol. 23, pp 9-18, 2001.
- [4] K. Arabi, M. A. Sawan, "Electronic Design of a Multichannel Programmable Implant for Neuromuscular Electrical Stimulation", *IEEE Trans. On Rehabilitation Engineering*, vol. 7, no 2, pp 204-214, June 1999.
- [5] R. Davis, T. Houdayer, B. Andrews, S. Emmons, J. Patrick, "Paraplegia: Prolonged Closed-Loop Standing with Implanted Nucleus FES-22 Stimulator and Andrews' Foot-Ankle Orthosis", in *Proc. of XIIth World Society of Stereotactic Functional Neurosurgery*, vol. 69, pp 281-287, 1997.
- [6] N. N. Donaldson, T. A. Perkins, A. C. M. Worley, "Lumbar Root Stimulation for Restoring Leg Function: Stimulator and Measurement of Muscle Actions", *Artificial Organs*, vol. 21, pp 247-249, 1997.
- [7] V. K. Mushahwar, K. W. Horch, "Proposed Specifications for a Lumbar Spinal Cord Electrode Array for Control of Lower Extremities in Paraplegia", *IEEE Trans. on Rehabilitation Engineering*, vol. 5, no 3, pp 237-243, September 1997.
- [8] C. Veraart, W. M. Grill, J. T. Mortimer, "Selective Control of Muscle Activation with a Multipolar Nerve Cuff Electrode", *IEEE Trans. On Biomedical Engineering*, vol. 40, no 7, pp 640-653, July 1993.
- [9] J. D. Sweeney, N. R. Crawford, T. A. Brandon, "Neuromuscular stimulation selectivity of multiple-contact nerve cuff electrode arrays", *Medical and Biological Engineering and Computing*, vol. 33, pp 418-425, 1995.
- [10] D. Guiraud, J. Galy, G. Cathébras, S. Bernard, D. Andreu, Y. Bertrand, J.-D. Techer. Dispositif de répartition de courant entre cathodes d'une électrode multipolaire notamment d'un implant. Patent n°04 09351, 3rd September 2004.