

An oriented coloring of graphs with maximum average degree less than $10/3$

Alexandre Pinlou

► **To cite this version:**

Alexandre Pinlou. An oriented coloring of graphs with maximum average degree less than $10/3$. RR-07024, 2007. lirmm-00186693v3

HAL Id: lirmm-00186693

<https://hal-lirmm.ccsd.cnrs.fr/lirmm-00186693v3>

Submitted on 12 Feb 2008

HAL is a multi-disciplinary open access archive for the deposit and dissemination of scientific research documents, whether they are published or not. The documents may come from teaching and research institutions in France or abroad, or from public or private research centers.

L'archive ouverte pluridisciplinaire **HAL**, est destinée au dépôt et à la diffusion de documents scientifiques de niveau recherche, publiés ou non, émanant des établissements d'enseignement et de recherche français ou étrangers, des laboratoires publics ou privés.

An oriented coloring of graphs with maximum average degree less than $\frac{10}{3}$

Alexandre Pinlou ¹

LIRMM - Univ. Montpellier 2, CNRS
161 rue Ada, 34392 Montpellier Cedex 5, France

Abstract

An oriented k -coloring of an oriented graph G is a homomorphism from G to an oriented graph H of order k . We prove that every oriented graph with maximum average degree less than $\frac{10}{3}$ has an oriented chromatic number at most 16. This implies that every oriented planar graph with girth at least five has an oriented chromatic number at most 16, that improves the previous known bound of 19 due to Borodin et al. [Borodin, O. V. and Kostochka, A. V. and Nešetřil, J. and Raspaud, A. and Sopena, É., *On the maximum average degree and the oriented chromatic number of a graph*, Discrete Math., 77–89, 206, 1999].

Key words: Oriented coloring; Planar graph; Girth; Discharging procedure; Maximum average degree.

1 Introduction

Oriented graphs are directed graphs without loops nor opposite arcs. For an oriented graph G , we denote by $V(G)$ its set of vertices and by $A(G)$ its set of arcs. For two adjacent vertices u and v , we denote by \vec{uv} the arc from u to v or simply uv whenever its orientation is not relevant (therefore, $uv = \vec{uv}$ or $uv = \vec{vu}$). The number of vertices of G is the *order* of G .

An *oriented k -coloring* of an oriented graph G is a mapping φ from $V(G)$ to a set of k colors such that (1) $\varphi(u) \neq \varphi(v)$ whenever \vec{uv} is an arc in G , and (2) $\varphi(u) \neq \varphi(x)$ whenever \vec{uv} and \vec{wx} are two arcs in G with $\varphi(v) = \varphi(w)$. In other

Email address: Alexandre.Pinlou@lirmm.fr (Alexandre Pinlou).

URL: www.lirmm.fr/~pinlou (Alexandre Pinlou).

¹ Département Mathématiques et Informatique Appliquées, Université Paul-Valéry, Montpellier 3, Route de Mende, 34199 Montpellier Cedex 5, France

words, an oriented k -coloring of G is a partition of the vertices of G into k stable sets S_1, S_2, \dots, S_k such that all the arcs between any pair of stable sets S_i and S_j have the same direction (either from S_i to S_j , or from S_j to S_i). The *oriented chromatic number* of an oriented graph, denoted by $\chi_o(G)$, is defined as the smallest k such that G admits an oriented k -coloring.

Let G and H be two oriented graphs. A *homomorphism* from G to H is a mapping $\phi: V(G) \rightarrow V(H)$ that preserves the arcs: $\overrightarrow{\phi(x)\phi(y)} \in A(H)$ whenever $\overrightarrow{xy} \in A(G)$.

An oriented k -coloring of G can be equivalently defined as a homomorphism from G to H , where H is an oriented graph of order k . The existence of such a homomorphism from G to H is denoted by $G \rightarrow H$. The vertices of H are called *colors*, and we say that G is H -colorable. The oriented chromatic number of G can then be defined as the smallest order of an oriented graph H such that $G \rightarrow H$. Links between colorings and homomorphisms are presented in more details in the recent monograph [6] by Hell and Nešetřil.

The notion of oriented coloring introduced by Courcelle [5] has been studied by several authors in the last decade and the problem of bounding the oriented chromatic number has been investigated for various graph classes: planar graphs (with given girth) [1–4,10,11], graphs with bounded maximum average degree [3,4], graphs with bounded degree [7], graphs with bounded treewidth [12,13], and graph subdivisions [15].

The *average degree* of a graph G , denoted by $\text{ad}(G)$, is defined as twice the number of edges over the number of vertices ($\text{ad}(G) = \frac{2|E(G)|}{|V(G)|}$). The *maximum average degree* of G , denoted by $\text{mad}(G)$, is then defined as the maximum of the average degrees taken over all subgraphs of G :

$$\text{mad}(G) = \max_{H \subseteq G} \{\text{ad}(H)\}.$$

The *girth* of a graph G is the length of a shortest cycle of G .

Borodin et al. [3,4] gave bounds of the oriented chromatic number of graphs with bounded maximum average degree:

Theorem 1 [3,4] *Let G be a graph.*

- (1) *If $\text{mad}(G) < \frac{12}{5}$ and G has girth at least 5, then $\chi_o(G) \leq 5$ [3].*
- (2) *If $\text{mad}(G) < \frac{11}{4}$ and G has girth at least 5, then $\chi_o(G) \leq 7$ [4].*
- (3) *If $\text{mad}(G) < 3$, then $\chi_o(G) \leq 11$ [4].*
- (4) *If $\text{mad}(G) < \frac{10}{3}$, then $\chi_o(G) \leq 19$ [4].*

When considering planar graphs, the maximum average degree and the girth are linked by the following well-known relation:

Claim 2 [4] *Let G be a planar graph with girth g . Then, $\text{mad}(G) < 2 + \frac{4}{g-2}$.*

Corollary 3 follows from Theorem 1 and the previous claim.

Corollary 3 [3,4] *Let G be a planar graph.*

- (1) *If G has girth at least 12, then $\chi_o(G) \leq 5$ [3].*
- (2) *If G has girth at least 8, then $\chi_o(G) \leq 7$ [4].*
- (3) *If G has girth at least 6, then $\chi_o(G) \leq 11$ [4].*
- (4) *If G has girth at least 5, then $\chi_o(G) \leq 19$ [4].*

In this paper, we consider the class of graphs with maximum average degree less than $\frac{10}{3}$. Our main result improves Theorem 1(4):

Theorem 4 *Let G be a graph with $\text{mad}(G) < \frac{10}{3}$. Then $\chi_o(G) \leq 16$.*

Actually, we prove a stronger result: we show that every oriented graph G with $\text{mad}(G) < \frac{10}{3}$ admits a homomorphism to T_{16} , where T_{16} is the Tromp graph of order 16 whose construction is described in Section 2.

We thus get:

Corollary 5 *Let G be a planar graph with girth at least 5. Then $\chi_o(G) \leq 16$.*

In the remainder, we use the following notions. For a vertex v of a graph G , we denote by $d_G^-(v)$ its *indegree*, by $d_G^+(v)$ its *outdegree*, and by $d_G(v)$ its degree (subscripts are omitted when the considered graph is clearly identified from the context). We denote by $N_G^+(v)$ the set of outgoing neighbors of v , by $N_G^-(v)$ the set of incoming neighbors of v and by $N_G(v) = N_G^+(v) \cup N_G^-(v)$ the set of neighbors of v . A vertex of degree k (resp. at least k , at most k) is called a *k -vertex* (resp. $\geq k$ -vertex, $\leq k$ -vertex). If a vertex u is adjacent to a k -vertex (resp. $\geq k$ -vertex, $\leq k$ -vertex) v , then v is a *k -neighbor* (resp. $\geq k$ -neighbor, $\leq k$ -neighbor) of u . A path of length k (i.e. formed by k edges) is called a *k -path*. If two graphs G and H are isomorphic, we denote it by $G \cong H$.

The paper is organised as follows. The next section is devoted to the target graph T_{16} and some of its properties. We prove Theorem 4 in Section 3. We finally give some concluding remarks in the last section.

2 The Tromp graph T_{16}

In this section, we describe the construction of the target graph T_{16} used to prove Theorem 4 and give some useful properties.

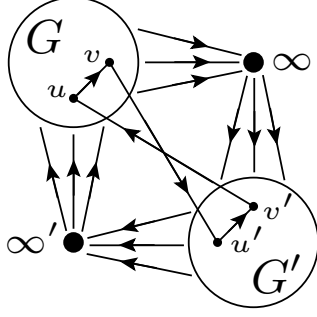

Fig. 1. The Tromp graph $Tr(G)$.

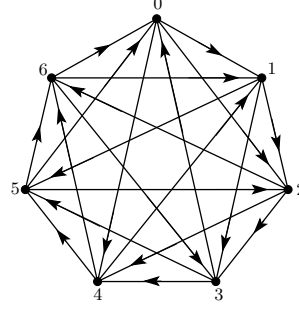

Fig. 2. The graph QR_7 .

Tromp's construction was proposed by Tromp [14]. Let G be an oriented graph and G' be an isomorphic copy of G . The Tromp graph $Tr(G)$ has $2|V(G)| + 2$ vertices and is defined as follows:

- $V(Tr(G)) = V(G) \cup V(G') \cup \{\infty, \infty'\}$
- $\forall u \in V(G) : \overrightarrow{u\infty}, \overrightarrow{\infty u'}, \overrightarrow{u'\infty'}, \overrightarrow{\infty' u} \in A(Tr(G))$
- $\forall u, v \in V(G), \overrightarrow{uv} \in A(G) : \overrightarrow{uv}, \overrightarrow{u'v'}, \overrightarrow{vu'}, \overrightarrow{v'u} \in A(Tr(G))$

Figure 1 illustrates the construction of $Tr(G)$. We can observe that, for every $u \in V(G) \cup \{\infty\}$, there is no arc between u and u' . Such pairs of vertices will be called *twin vertices*, and we denote by $t(u)$ the twin vertex of u . Remark that $t(t(u)) = u$. This notion can be extended to sets in a standard way: for a given $W \subseteq V(G)$, $W = \{v_1, v_2, \dots, v_k\}$, then $t(W) = \{t(v_1), t(v_2), \dots, t(v_k)\}$.

By construction, the graph $Tr(G)$ satisfies the following property:

$$\forall u \in Tr(G) : N^+(u) = N^-(t(u)) \text{ and } N^-(u) = N^+(t(u))$$

In the remainder, we focus on the specific graph family obtained via the Tromp's construction applied to Paley tournaments. For a prime power $p \equiv 3 \pmod{4}$, the *Paley tournament* QR_p is defined as the oriented graph whose vertices are the integers modulo p and such that \overrightarrow{uv} is an arc if and only if $v - u$ is a non-zero quadratic residue of p . For instance, the Paley tournament QR_7 has vertex set $V(QR_7) = \{0, 1, \dots, 6\}$ and $\overrightarrow{uv} \in A(QR_7)$ whenever $v - u \equiv r \pmod{7}$ for $r \in \{1, 2, 4\}$; see Figure 2. Note that the bounds of Theorems 1(2), 1(3), and 1(4) have been obtained by proving that all the graphs of the considered classes admit a homomorphism to the Paley tournaments QR_7 , QR_{11} , and QR_{19} , respectively.

Let $T_{16} = Tr(QR_7)$ be the Tromp graph on sixteen vertices obtained from QR_7 . In the remainder of this paper, the vertex set of T_{16} is $\{0, 1, \dots, 6, \infty, 0', 1', \dots, 6', \infty'\}$ where $\{0, 1, \dots, 6\}$ is the vertex set of the first copy of QR_7 and $\{0', 1', \dots, 6'\}$ is the vertex set of the second copy of QR_7 ; thus, for every $u \in \{0, 1, \dots, 6, \infty\}$, we have $t(u) = u'$. In addition, for every $u \in V(T_{16})$, we have by construction $|N_{T_{16}}^+(u)| = |N_{T_{16}}^-(u)| = 7$. The graph T_{16} has remarkable symmetry and some useful properties

given below.

Proposition 6 [8] For any QR_p , the graph $Tr(QR_p)$ is such that:

$$\forall u \in V(Tr(QR_p)) : N^+(u) \cong QR_p \text{ and } N^-(u) \cong QR_p$$

Proposition 7 [8] For any QR_p , if $\{a_1, a_2, a_3\}$ and $\{b_1, b_2, b_3\}$ span triangles t_1 and t_2 respectively in $Tr(QR_p)$ and the map ψ taking a_i to b_i ($1 \leq i \leq 3$) is an isomorphism $t_1 \rightarrow t_2$, then ψ can be extended to an automorphism of $Tr(QR_p)$.

It is then clear that $Tr(QR_p)$ is vertex-transitive and arc-transitive.

Proposition 8 Let G be an oriented graph such that $G \rightarrow T_{16}$. Then, for any vertex v of G , the graph G' obtained from G by reversing the orientation of every arc incident to v admits a homomorphism to T_{16} .

Proof. Let ϕ be a T_{16} -coloring of G . For every $w \in V(T_{16})$, we have $N_{T_{16}}^+(w) = N_{T_{16}}^-(t(w))$ and $N_{T_{16}}^-(w) = N_{T_{16}}^+(t(w))$. Therefore, the mapping $\phi' : V(G') \rightarrow V(T_{16})$ defined by $\phi'(u) = \phi(u)$ for all $u \in V(G') \setminus \{v\}$ and $\phi'(v) = t(\phi(v))$ is clearly a T_{16} -coloring of G' . \square

An *orientation n -vector* is a sequence $\alpha = (\alpha_1, \alpha_2, \dots, \alpha_n) \in \{0, 1\}^n$ of n elements. Let $S = (v_1, v_2, \dots, v_n)$ be a sequence of n (not necessarily distinct) vertices of T_{16} ; a vertex u is said to be an α -*successor* of S if for any i , $1 \leq i \leq n$, we have $\overrightarrow{uv_i} \in A(T_{16})$ whenever $\alpha_i = 1$ and $\overrightarrow{v_i u} \in A(T_{16})$ otherwise. For instance, the vertex $3'$ of T_{16} is a $(1, 1, 0, 1, 0, 0)$ -successor of $(1, 2, 6', 1, \infty, 2')$ since the arcs $\overrightarrow{3'1}$, $\overrightarrow{3'2}$, $\overrightarrow{6'3'}$, $\overrightarrow{\infty 3'}$, and $\overrightarrow{2'3'}$ belong to $A(T_{16})$.

If, for a sequence $S = (v_1, v_2, \dots, v_n)$ of n vertices of T_{16} and an orientation n -vector $\alpha = (\alpha_1, \alpha_2, \dots, \alpha_n)$, there exist $i \neq j$ such that $v_i = v_j$ and $\alpha_i \neq \alpha_j$, then there does not exist any α -successor of S ; indeed, T_{16} does not contain opposite arcs. In addition, if there exist $i \neq j$ such that $v_i = t(v_j)$ and $\alpha_i = \alpha_j$, then there does not exist any α -successor of S ; indeed, for any pair of vertices x and y of T_{16} with $x = t(y)$, we have $N_{T_{16}}^+(x) \cap N_{T_{16}}^+(y) = \emptyset$ and $N_{T_{16}}^-(x) \cap N_{T_{16}}^-(y) = \emptyset$. A sequence $S = (v_1, v_2, \dots, v_n)$ of n vertices of T_{16} is said to be *compatible* with an orientation n -vector $\alpha = (\alpha_1, \alpha_2, \dots, \alpha_n)$ if and only if for any $i \neq j$, we have $\alpha_i \neq \alpha_j$ whenever $v_i = t(v_j)$, and $\alpha_i = \alpha_j$ whenever $v_i = v_j$. Note that if the n vertices of S induce an n -clique subgraph of T_{16} (i.e. v_1, v_2, \dots, v_n are pairwise distinct and induce a complete graph), then S is compatible with any orientation n -vector since a vertex u and its twin $t(u)$ cannot belong together to the same clique.

In the remainder, we say that T_{16} has *Property $P_{n,k}$* if, for every sequence S of n distinct vertices of T_{16} and any orientation n -vector α which is compatible with S , there exist k α -successors of S . This set of k α -successors is denoted by $\text{Succ}_\alpha(S)$.

Proposition 9 *The graph T_{16} has Properties $P_{1,7}$, $P_{2,3}$, and $P_{3,1}$.*

Proof.

- (1) Property $P_{1,7}$ is trivial since every vertex of T_{16} has seven successors and seven predecessors.
- (2) To prove that T_{16} has Property $P_{2,3}$, we have to show that, for every sequence $S = (u, v)$ and any compatible orientation 2-vector α , there exist at least three α -successors of S . We have two cases to consider: the case $uv \in A(T_{16})$ and the case $u = t(v)$. Since T_{16} is arc-transitive, we will consider w.l.o.g. $S = (0, 1)$ and $S = (\infty, \infty')$.

A case study shows that the three α -successors of $S = (0, 1)$ are $2, 6'$, and ∞ (resp. $2', 6$, and ∞' ; $3', 4$, and $5'$; $3, 4'$, and 5) if $\alpha = (0, 0)$ (resp. $(1, 1)$; $(0, 1)$; $(1, 0)$).

Consider now the case $S = (\infty, \infty')$. By definition, the only two compatible orientation 2-vectors with S are $(0, 1)$ and $(1, 0)$. It is then clear by construction of T_{16} that we have seven α -successors of S in each case.

- (3) Property $P_{3,1}$ was proved by Marshall [8].

□

Proposition 10 *Let u, v_1 , and v_2 be three distinct vertices of T_{16} , and $S_i = (u, v_i)$ for every $1 \leq i \leq 2$. Let α be an orientation 2-vector compatible with S_1 and S_2 . Then $\text{Succ}_\alpha(S_1) \neq \text{Succ}_\alpha(S_2)$.*

Proof. Suppose to the contrary that there exist such S_1 and S_2 with $\text{Succ}_\alpha(S_1) = \text{Succ}_\alpha(S_2)$.

By Proposition 8, we may assume w.l.o.g. that $\alpha_2 = 0$. If $v_1 = t(v_2)$, we clearly have $\text{Succ}_\alpha(S_1) \neq \text{Succ}_\alpha(S_2)$ since $N_{T_{16}}^+(v_1) \cap N_{T_{16}}^+(v_2) = \emptyset$. Thus, we may assume w.l.o.g. that $v_1 v_2 \in A(T_{16})$, and since T_{16} is arc-transitive, we assume w.l.o.g. that $v_1 = 0$ and $v_2 = 1$.

Therefore, the vertices of $\text{Succ}_\alpha(S_1) = \text{Succ}_\alpha(S_2)$ must be the common successors of 0 and 1. We have $N_{T_{16}}^+(0) \cap N_{T_{16}}^+(1) = \{2, 6', \infty\}$. If $\alpha_1 = 0$, then a case study allows us to check that T_{16} has no vertex u distinct from 0 and 1 having 2, $6'$, and ∞ as successors. Therefore, we should have $\alpha_1 = 1$ and then we can check that u should necessarily be either $0'$ or $1'$. However, in each case, we will have $|\text{Succ}_\alpha(S_i)| = 7$ and $|\text{Succ}_\alpha(S_{3-i})| = 3$ for some $i \in [1, 2]$. □

Proposition 11 *Let u, v_1, v_2 , and v_3 be four distinct vertices of T_{16} , and $S_i = (u, v_i)$ for every $1 \leq i \leq 3$. Let α be an orientation 2-vector compatible with S_1, S_2 , and S_3 . Then, for any pair of vertices $W = \{x, y\}$ of T_{16} , there exists $j \in [1, 3]$ such that $|\text{Succ}_\alpha(S_j) \setminus W| \geq 2$.*

Proof. Remark first that if there exists $j \in [1, 3]$ such that $uv_j \notin A(T_{16})$, then we necessarily have $u = t(v_j)$ and thus $\alpha_1 \neq \alpha_2$ since α is compatible with S_j . In this case, we have $|\text{Succ}_\alpha(S_j)| = 7$ and it is clear that $|\text{Succ}_\alpha(S_j) \setminus W| \geq 2$. Therefore, $uv_1, uv_2, uv_3 \in A(T_{16})$, and thus, for every $i \in [1, 3]$, $|\text{Succ}_\alpha(S_i)| = 3$.

Suppose that the proposition is false, that is there exist u, v_1, v_2, v_3 and a pair of vertices $W = \{x, y\}$ such that $W \subset \bigcap_{i=1}^3 \text{Succ}_\alpha(S_i)$.

Remark that, for any sequence S of size n and any orientation n -vector β , the set $\text{Succ}_\beta(S)$ cannot contain a vertex together with its twin. Therefore, $x \neq t(y)$ and since T_{16} is arc-transitive, we may assume w.l.o.g. that $W = \{0, 1\}$.

Therefore, u (resp. v_1, v_2 , and v_3) should belong to $N_{T_{16}}^+(0) \cap N_{T_{16}}^+(1) = \{2, 6', \infty\}$ if $\alpha_1 = 0$ (resp. $\alpha_2 = 0$) or to $N_{T_{16}}^-(0) \cap N_{T_{16}}^-(1) = \{2', 6, \infty'\}$ if $\alpha_1 = 1$ (resp. $\alpha_2 = 1$). This implies that, if $\alpha_1 = \alpha_2$ (resp. $\alpha_1 \neq \alpha_2$), we would have $u = v_j$ (resp. $u = t(v_j)$) for some $j \in [1, 3]$, that contradicts the fact that $uv_1, uv_2, uv_3 \in A(T_{16})$. \square

3 Proof of Theorem 4

In this section, we prove Theorem 4, that is that every graph G with $\text{mad}(G) < \frac{10}{3}$ admits a homomorphism to T_{16} .

Let us define the partial order \preceq . Let $n_3(G)$ be the number of ≥ 3 -vertices in G . For any two graphs G_1 and G_2 , we have $G_1 \prec G_2$ if and only if at least one of the following conditions hold:

- G_1 is a proper subgraph of G_2 ;
- $n_3(G_1) < n_3(G_2)$.

Note that this partial order is well-defined, since if G_1 is a proper subgraph of G_2 , then $n_3(G_1) \leq n_3(G_2)$. So \preceq is a partial linear extension of the subgraph poset.

Let H be a hypothetical minimal counterexample to Theorem 4 according to \prec . We first prove that H does not contain a set of fifteen configurations. Then, using a discharging procedure, we show that every graph which contains none of these fifteen configurations has a maximum average degree greater than $\frac{10}{3}$; this implies that H has $\text{mad}(H) \geq \frac{10}{3}$, a contradiction.

3.1 Structural properties of H

A *weak 5-vertex* is a 5-vertex adjacent to three 2-vertices. A *weak 4-vertex* is a 4-vertex adjacent to one 2-vertex.

Lemma 12 *The graph H does not contain the following configurations:*

- (C1) *a ≤ 1 -vertex;*
- (C2) *a k -vertex adjacent to $(k - 2)$ 2-vertices for $3 \leq k \leq 4$;*
- (C3) *a k -vertex adjacent to $(k - 1)$ 2-vertices for $2 \leq k \leq 7$;*
- (C4) *a k -vertex adjacent to k 2-vertices for $1 \leq k \leq 15$;*
- (C5) *a 3-vertex;*
- (C6) *a triangle incident to a 2-vertex;*
- (C7) *two vertices sharing three neighbors whose two of them are 2-vertices;*
- (C8) *a k -vertex adjacent to $(k - 2)$ 2-vertices and one weak 5-vertex for $5 \leq k \leq 6$;*
- (C9) *a 4-vertex adjacent to three weak 5-vertices;*
- (C10) *a weak 5-vertex adjacent to two weak 4-vertices;*
- (C11) *a 5-vertex adjacent to two 2-vertices and two weak 5-vertices;*
- (C12) *a 5-vertex adjacent to one 2-vertex and four weak 5-vertices;*
- (C13) *a 6-vertex adjacent to three 2-vertices and three weak 5-vertices;*
- (C14) *a 7-vertex adjacent to five 2-vertices and two weak 5-vertices;*
- (C15) *an 8-vertex adjacent to seven 2-vertices and one weak 5-vertex.*

The drawing conventions for a *configuration* C contained in a graph G are the following. If u and v are two vertices of C , then they are adjacent in G if and only if they are adjacent in C . Moreover, the neighbors of a *white* vertex in G are exactly its neighbors in C , whereas a *black* vertex may have neighbors outside of C . Two or more black vertices in C may coincide in a single vertex in G , provided they do not share a white neighbor. Finally, an edge will represent an arc with any of its two possible orientations.

Let G be an oriented graph, v be a k -vertex with $N(v) = \{v_1, v_2, \dots, v_k\}$ and α be an orientation k -vector such that $\alpha_i = 0$ whenever $\overrightarrow{v_i v} \in A(G)$ and $\alpha_i = 1$ otherwise. Let φ be a T_{16} -coloring of $G \setminus \{v\}$ and $S = (\varphi(v_1), \varphi(v_2), \dots, \varphi(v_k))$. Recall that a necessary condition to have α -successors of S is that α must be compatible with S , that is for any pair of vertices v_i and v_j , $\varphi(v_i) \neq \varphi(v_j)$ whenever $\alpha_i \neq \alpha_j$ and $\varphi(v_i) \neq t(\varphi(v_j))$ whenever $\alpha_i = \alpha_j$. Hence, every vertex v_j forbids one color for each vertex v_i , $i \in [1, k]$, $i \neq j$. We define $f_{v_i}^\varphi(v_j)$ to be the forbidden color for v_i by $\varphi(v_j)$ (i.e. $f_{v_i}^\varphi(v_j) = \varphi(v_j)$ whenever $\alpha_i \neq \alpha_j$ and $f_{v_i}^\varphi(v_j) = t(\varphi(v_j))$ whenever $\alpha_i = \alpha_j$). Therefore, α is compatible with S if and only if we have $\varphi(v_i) \neq f_{v_i}^\varphi(v_j)$ for every pair i, j , $1 \leq i < j \leq k$. Note that if $\varphi(v_i) \neq f_{v_i}^\varphi(v_j)$, then we necessarily have $\varphi(v_j) \neq f_{v_j}^\varphi(v_i)$.

For each configuration, we suppose that H contains it and we consider a reduction H' such that $H' \prec H$ and $\text{mad}(H') < \frac{10}{3}$; therefore, by minimality of H , H' admits a T_{16} -coloring φ . We will then show that we can choose φ so that it can be extended to H by Proposition 9, contradicting the fact that H is counterexample.

In the remainder, if H contains a configuration, then H^* will denote the graph obtained from H by removing all the white vertices of this configuration.

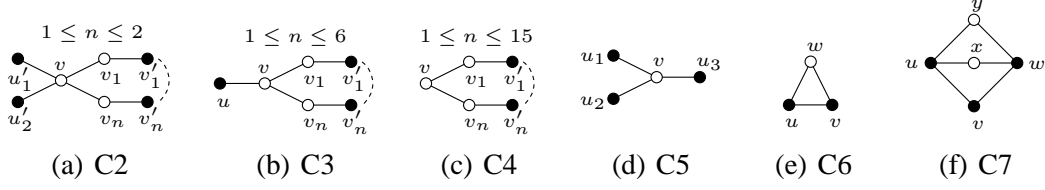

Fig. 3. Configurations C2-C7.

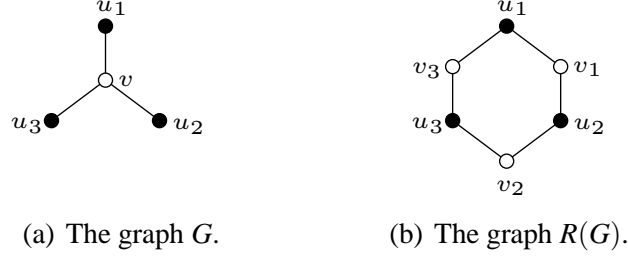

Fig. 4. Configurations of Lemma 13.

Proof of Configuration (C1). Trivial. \square

Proof of Configuration (C2). Suppose that H contains the configuration depicted in Figure 3(a) and let φ be a T_{16} -coloring of $H' = H \setminus \{v_1, \dots, v_n\}$. Then, we clearly have $\varphi(u'_1) \neq f_{u'_1}^\varphi(u'_2)$ since v is colored in H' . Therefore, by Property $P_{2,3}$, we can choose φ so that $\varphi(v) \notin \{f_v^\varphi(v'_1), \dots, f_v^\varphi(v'_n)\}$. \square

Proof of Configuration (C3). Suppose that H contains the configuration depicted in Figure 3(b) and let φ be a T_{16} -coloring of H^* . By Property $P_{1,7}$, we can choose φ so that $\varphi(v) \notin \{f_v^\varphi(v'_1), \dots, f_v^\varphi(v'_n)\}$. \square

Proof of Configuration (C4). Suppose that H contains the configuration depicted in Figure 3(c) and let φ be a T_{16} -coloring of H^* . We can clearly choose φ so that $\varphi(v) \notin \{f_v^\varphi(v'_1), \dots, f_v^\varphi(v'_n)\}$. \square

Up to now, the reductions H' have been obtained from H by removing some vertices and/or arcs; therefore, we clearly had $\text{mad}(H') \leq \text{mad}(H)$. To prove that Configuration (C5) is forbidden in H , we considered a reduction H' obtained from H by removing one 3-vertex and by adding new vertices and arcs. The following lemma shows that this reduction H' has nevertheless a maximum average degree strictly less than $\frac{10}{3}$.

Let G be a graph containing a 3-vertex v adjacent to three vertices $u_1, u_2,$ and u_3 ; see Figure 4(a). We denote by $R(G)$ the graph obtained from $G \setminus \{v\}$ by adding 2-paths joining respectively u_1 and u_2, u_2 and u_3, u_3 and u_1 ; see Figure 4(b).

Lemma 13 *If $\text{mad}(G) < \frac{10}{3}$, then $\text{mad}(R(G)) < \frac{10}{3}$.*

Proof. Let G' be a counterexample, i.e. $\text{mad}(G') < \frac{10}{3}$ and $\text{mad}(R(G')) \geq \frac{10}{3}$.

Let $D \subseteq R(G')$ be a minimal subgraph of $R(G')$ (in term of $|V(D)| + |E(D)|$) such that $\text{ad}(D) = \text{mad}(R(G'))$ (by definition of the maximum average degree, D exists). Let $W = V(D) \setminus \{u_1, u_2, u_3, v_1, v_2, v_3\}$ and $F = E(D) \setminus \{u_1v_1, v_1u_2, u_2v_2, v_2u_3, u_3v_3, v_3u_1\}$. Hence, W (resp. F) is the set of vertices (resp. edges) of D belonging to G' and $R(G')$ which are not drawn on Figure 4(b).

It is obvious that D is not a subgraph of G' since otherwise we would have $\text{mad}(G') \geq \frac{10}{3}$. Moreover, suppose that D contains a ≤ 1 -vertex x and let $D' = D \setminus \{x\}$; we then have $\text{ad}(D') > \text{ad}(D)$ since $\text{ad}(D) > 2$, that contradicts the minimality of D .

Therefore, since $D \not\subseteq G'$ and the minimum degree of D is 2, we have to consider w.l.o.g. two different cases:

- (1) $V(D) = W \cup \{u_1, v_1, u_2, v_2, u_3, v_3\}$ and $E(D) = F \cup \{u_1v_1, v_1u_2, u_2v_2, v_2u_3, u_3v_3, v_3u_1\}$. In this case, let $D' \subseteq G'$ such that $V(D') = W \cup \{u_1, u_2, u_3, v\}$ and $E(D') = F \cup \{u_1v, u_2v, u_3v\}$. Therefore, $|V(D')| = |V(D)| - 2$ and $|E(D')| = |E(D)| - 3$. Since $\text{ad}(D) \geq \frac{10}{3}$, we have $6|E(D)| \geq 10|V(D)|$ and thus $6(|E(D)| - 3) \geq 10(|V(D)| - 2)$. Hence $6|E(D')| \geq 10|V(D')|$, that proves that $\text{ad}(D') \geq \frac{10}{3}$ and thus $\text{mad}(G') \geq \frac{10}{3}$, a contradiction.
- (2) $V(D) = W \cup \{u_1, v_1, u_2, v_2, u_3\}$ and $E(D) = F \cup \{u_1v_1, v_1u_2, u_2v_2, v_2u_3\}$. The same kind of arguments lead us to a similar contradiction.

Therefore, the graph G' does not exist. \square

Proof of Configuration (C5). Suppose that H contains the configuration depicted in Figure 3(d). Since Configurations (C1) and (C2) are forbidden, $u_1, u_2,$ and u_3 are ≥ 3 -vertices. Let H' be the graph obtained from H^* by adding, for every $1 \leq i < j \leq 3$, a 2-path joining u_i to u_j in such a way that its orientation is the same orientation of the path $[u_i, v, u_j]$ in H . We have $H' \prec H$ since $n_3(H') = n_3(H) - 1$ and $\text{mad}(H') < \frac{10}{3}$ by Lemma 13. Any T_{16} -coloring ϕ of H' induces a coloring of H^* such that $\phi(u_i) \neq f_{u_i}^\phi(u_j)$ for any $i, j, 1 \leq i < j \leq 3$. \square

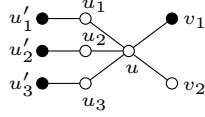

Fig. 5. Configuration of Lemma 14.

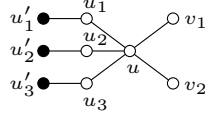

Fig. 6. Configuration of Lemma 15.

Proof of Configuration (C6). Suppose that H contains the configuration depicted in Figure 3(e). Any T_{16} -coloring φ of H^* is such that $\varphi(u) \neq f_u^\varphi(v)$ since $uv \in A(H)$. \square

Proof of Configuration (C7). Suppose that H contains the configuration depicted in Figure 3(f). Let H' be the graph obtained from H^* by adding an alternating (resp. directed) 2-path joining u and w if the 2-path $[u, v, w]$ is directed (resp. alternating). We have $H' \prec H$ and at least two 2-paths join u and w in H' : the first one is alternating and the other one is directed. Therefore, any T_{16} -coloring φ of H' induces a coloring of H^* such that $\varphi(u) \neq \varphi(w)$ and $\varphi(u) \neq t(\varphi(w))$. \square

Some sub-configurations appear several times in Configurations (C8) to (C15). To shorten the proofs, we will often use the five following lemmas.

Lemma 14 *Let G be an oriented graph containing a weak 5-vertex u (see Figure 5) and let φ be a T_{16} -coloring of G^* . Then, for a fixed coloring of u'_1, u'_2, u'_3 , and v_1 , at most two colors are forbidden for v_2 .*

Proof. The color $\varphi(v_1)$ together with each of the fifteen colors for v_2 distinct from $f_1 = f_{v_2}^\varphi(v_1)$ give three possible colors for u by Property $P_{2,3}$. Proposition 10 insures that at most one of these fifteen colors, say f_2 , gives the three colors $f_u^\varphi(u'_1), f_u^\varphi(u'_2)$, and $f_u^\varphi(u'_3)$ for u . Thus, for any $\varphi(v_2) \notin \{f_1, f_2\}$, we have three available colors for u whose one of them is distinct from $f_u^\varphi(u'_1), f_u^\varphi(u'_2)$, and $f_u^\varphi(u'_3)$. \square

Lemma 15 *Let G be an oriented graph containing a weak 5-vertex (see Figure 6) and let φ be a T_{16} -coloring of G^* . Then, for any $V_1 \subset V(T_{16})$ and $V_2 \subset V(T_{16})$ such that $|V_1| = |V_2| = 2$, φ can be extended to G so that the colors of u'_1, u'_2 , and u'_3 are fixed and $\varphi(v_i) \in V_i$.*

Proof. Let $W = \{f_u^\varphi(u'_1), f_u^\varphi(u'_2), f_u^\varphi(u'_3)\}$. Remark first that we must have $\varphi(u) \notin W$.

Let $V_1 = \{c_1, c_2\}$ and $V_2 = \{d_1, d_2\}$ and let $\alpha = (\alpha_1, \alpha_2)$ be an orientation 2-vector such that, for every $i \in [1, 2]$, $\alpha_i = 0$ whenever $\overrightarrow{v_i u} \in A(G)$, and $\alpha_i = 1$ otherwise.

Suppose first that $V_1 = V_2$ (more precisely, $c_i = d_i$ for every $i \in [1, 2]$). If $\alpha_1 = \alpha_2$, then we set $\varphi(v_1) = \varphi(v_2)$, and we get $|\text{Succ}_\alpha(\varphi(v_1), \varphi(v_2))| = 7$. Thus, φ can be

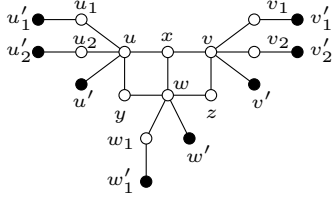

Fig. 7. Configuration of Lemma 16.

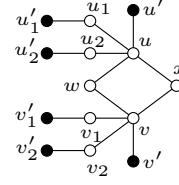

Fig. 8. Configuration of Lemma 17.

extended to G . If $\alpha_1 \neq \alpha_2$, then let $S_1 = (c_1, d_2)$ and $S_2 = (c_2, d_1)$. The sequences S_1 and S_2 are compatible with α , and by Property $P_{2,3}$ we have $|\text{Succ}_\alpha(S_i)| \geq 3$ for every $i \in [1, 2]$. Moreover, a case study shows that $\text{Succ}_\alpha(S_1) = t(\text{Succ}_\alpha(S_2))$. Therefore, there exists $i \in [1, 2]$ such that $\text{Succ}_\alpha(S_i) \neq W$, and so φ can be extended to G .

Suppose now that $V_1 \neq V_2$. If there exists $i \in [1, 2]$ such that the arcs $c_i d_1$ and $c_i d_2$ exist in T_{16} , say $i = 1$, then $c_1 \neq d_1 \neq d_2 \neq c_1$ and therefore the sequences $S_1 = (c_1, d_1)$ and $S_2 = (c_1, d_2)$ are compatible with α and Proposition 10 insures that there exist $i \in [1, 2]$ such that $\text{Succ}_\alpha(S_i) \neq W$. If there exists $i \in [1, 2]$ such that the arcs $c_i d_1$ and $c_i d_2$ do not exist in T_{16} , say $i = 1$, then it means that $c_1 = d_1$ and $c_1 = t(d_2)$. This leads us to the previous case, that is the two arcs $c_2 d_1$ and $c_2 d_2$ exist in T_{16} and $c_2 \neq d_1 \neq d_2 \neq c_2$. The last case to consider is the one where $c_1 d_1$ and $c_2 d_2$ exist in T_{16} , and $c_1 d_2$ and $c_2 d_1$ do not exist in T_{16} . We can check that we then have either (1) $c_1 = d_2$ and $c_2 = t(d_1)$, or (2) $c_1 = t(d_2)$ and $c_2 = t(d_1)$. If $\alpha_1 \neq \alpha_2$, then for both Cases (1) and (2), the sequence $S = (c_2, d_1)$ is compatible with α and we clearly have $\text{Succ}_\alpha(S) \neq W$ since $|\text{Succ}_\alpha(S)| = 7$. Finally, if $\alpha_1 = \alpha_2$, then for Case (1), the sequence $S = (c_1, d_2)$ is compatible with α and we clearly have $\text{Succ}_\alpha(S) \neq W$ since $|\text{Succ}_\alpha(S)| = 7$; for Case (2), the sequences $S_1 = (c_1, d_1)$ and $S_2 = (c_2, d_2)$ are compatible with α , and since $N_{T_{16}}^+(c_1) \cap N_{T_{16}}^+(d_2) = \emptyset$, we clearly have $\text{Succ}_\alpha(S_1) \neq \text{Succ}_\alpha(S_2)$ and thus there exists $i \in [1, 2]$ such that $\text{Succ}_\alpha(S_i) \neq W$. \square

Lemma 16 *Let G be an oriented graph containing a ≥ 3 -vertex x adjacent to three weak 5-vertices u, v , and w such that u and w (resp. v and w) share a 2-neighbor (see Figure 7). Let φ be a T_{16} -coloring of G^* . Then, for a fixed coloring of $u', u'_1, u'_2, v', v'_1, v'_2, w'$ and w'_1 , at most five colors are forbidden for x .*

Proof. To prove this lemma, we will show that for any $W \subset V(T_{16})$ such that $|W| = 6$, φ can be extended to G so that the colors of $u', u'_1, u'_2, v', v'_1, v'_2$ and w'_1 are fixed and $\varphi(x) \in W$.

Let $W' = \{f_x^\varphi(u'), f_x^\varphi(v'), f_x^\varphi(w')\}$. Remark first that we must have $\varphi(x) \notin W'$. Let $W'' = W \setminus W'$ and consider the worst case $|W''| = 3$. By Proposition 11, there exists a color $c \in W''$ such that $\varphi(x) = c$ and $\varphi(u')$ allow three colors for u by Property $P_{2,3}$ whose two of them are distinct from $f_u^\varphi(u'_1)$ and $f_u^\varphi(u'_2)$. We then set $\varphi(x) = c$.

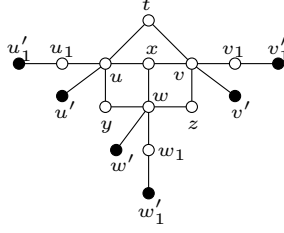

Fig. 9. Configurations of Lemma 18.

By Property $P_{2,3}$, $\varphi(v')$ and $\varphi(x)$ allow three colors for v : we can then set $\varphi(v) \notin \{f_v^\varphi(v'_1), f_v^\varphi(v'_2)\}$. Then, by Property $P_{2,3}$, $\varphi(w')$ and $\varphi(x)$ allow three colors for w : we can then set $\varphi(w) \notin \{f_w^\varphi(w'_1), f_w^\varphi(v)\}$. Finally, recall that $\varphi(u')$ and $\varphi(x)$ allow three colors for v whose two of them are distinct from $f_u^\varphi(u'_1)$ and $f_u^\varphi(u'_2)$: therefore, we can then set $\varphi(u) \notin \{f_u^\varphi(u'_1), f_u^\varphi(u'_2), f_u^\varphi(w)\}$. \square

Lemma 17 *Let G be an oriented graph containing a ≥ 3 -vertex adjacent to two weak 5-vertices u and v sharing a 2-neighbor (see Figure 8) and let φ be a T_{16} -coloring of G^* . Then, for a fixed coloring of $u'_1, u'_2, v'_1, v'_2, u'$ and v' , at most four colors are forbidden for x .*

The proof of this lemma is omitted.

Lemma 18 *Let G be an oriented graph containing a ≥ 3 -vertex x adjacent to three weak 5-vertices u, v , and w such that u and w (resp. v and w ; u and w) share a 2-neighbor (see Figure 9). Let φ be a T_{16} -coloring of G^* and let $W \subset V(T_{16})$ containing the seven successors of any vertex of T_{16} . Then, for a fixed coloring of $u', u'_1, v', v'_1, w',$ and w'_1 , φ can be extended to G such that $\varphi(x) \in W$.*

Proof. Let $G' = G \setminus \{t, y, z\}$. We first show that if we can extend φ to G' so that we have three choices of colors for one of the vertices u, v , or w , say u , and two choices of colors for one the vertices v or w , say v , then there exists a T_{16} -coloring of G . Let S_u and S_v be any two sets of vertices of T_{16} such that $|S_u| = 3$ and $|S_v| = 2$. If, for any colors $c_u \in S_u$ and $c_v \in S_v$, there exists a T_{16} -coloring φ' of G' such that $\varphi'(u) = c_u$ and $\varphi'(v) = c_v$, then we can choose $\varphi(v) \in S_v \setminus \{f_v^{\varphi'}(w)\}$ and $\varphi(u) \in S_u \setminus \{f_u^{\varphi'}(v), f_u^{\varphi'}(w)\}$; this coloring can clearly be extended to G by Proposition 9.

We may suppose w.l.o.g. that the seven vertices of W are the seven successors of ∞ . Let $W' = \{f_x^\varphi(u'), f_x^\varphi(v'), f_x^\varphi(u'')\}$. Remark first that we must have $\varphi(x) \notin W'$. Let $W'' = W \setminus W'$ and consider the worst case $|W''| = 4$. By Property $P_{2,3}$, for each $\varphi(x) \in W''$, we have at least two colors distinct from $f_u^\varphi(u'_1)$ (resp. $f_v^\varphi(v'_1), f_w^\varphi(w'_1)$) for u (resp v, w) in G' .

Actually, we can show that at least one color $\varphi(x) \in W''$ allows three colors for either u, v , or w , that is either three colors for u distinct from $f_u^\varphi(u'_1)$, three colors

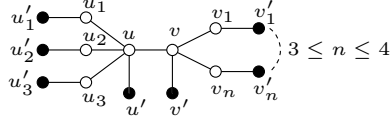

Fig. 10. Configuration (C8): a k -vertex adjacent to $(k-2)$ 2-vertices and one weak 5-vertex for $5 \leq k \leq 6$.

for v distinct from $f_v^\phi(v'_1)$, or three colors for w distinct from $f_w^\phi(w'_1)$. A case study shows that if one of the following condition holds:

- (1) $\phi(u') = \infty$,
- (2) $\phi(u') = \infty'$,
- (3) $\phi(u')$ is a predecessor of ∞ and the 2-path $[u', u, x]$ is alternating,
- (4) $\phi(u')$ is a successor of ∞ and the 2-path $[u', u, x]$ is directed,

then, for any $f_u^\phi(u'_1)$, there exists a color $\phi(x) \in W''$ such that the three colors for u given by Property $P_{2,3}$ are distinct from $f_u^\phi(u'_1)$. The coloring ϕ can then be extended to G by the above remark. By symmetry, these arguments apply for v' and w' .

Otherwise, suppose that $\phi(u') = s$ is a successor of ∞ and the 2-path $[u', u, x]$ is alternating. If $s \in W''$, then we can set $\phi(x) = s$ and we have seven available colors for u , that completes the proof. If $s \notin W''$, then this implies that $s \in W' = \{f_x^\phi(u'), f_x^\phi(v'), f_x^\phi(w')\}$ since $s \in W$ by definition of W . Therefore, we necessarily have w.l.o.g. either $\phi(v') = s$ and $[v', v, x]$ is directed, or $\phi(v') = t(s)$ and $[v', v, x]$ is alternating, the only two cases which forbid the color s for x . However, we have already shown that for these two cases, ϕ can be extended to a T_{16} -coloring of G (see above conditions (3) and (4)). \square

Proof of Configuration (C8). Suppose that H contains the configuration depicted in Figure 10 and let ϕ be a T_{16} -coloring of H^* . By Lemma 14, the weak 5-vertex u forbids two colors for v , say f_1 and f_2 . By Property $P_{1,7}$, we can choose ϕ such that $\phi(v) \notin \{f_1, f_2, f_v^\phi(v'_1), \dots, f_v^\phi(v'_n)\}$. \square

Recall that the case where two black vertices coincide in a configuration (provided they do not share a white neighbor) is already taken into account in the proofs. However, since we have no restriction on the girth of the considered graphs, the cases where black vertices coincide with white vertices have to be considered. To prove that Configurations (C8) to (C15) are forbidden, we first begin by the following remarks:

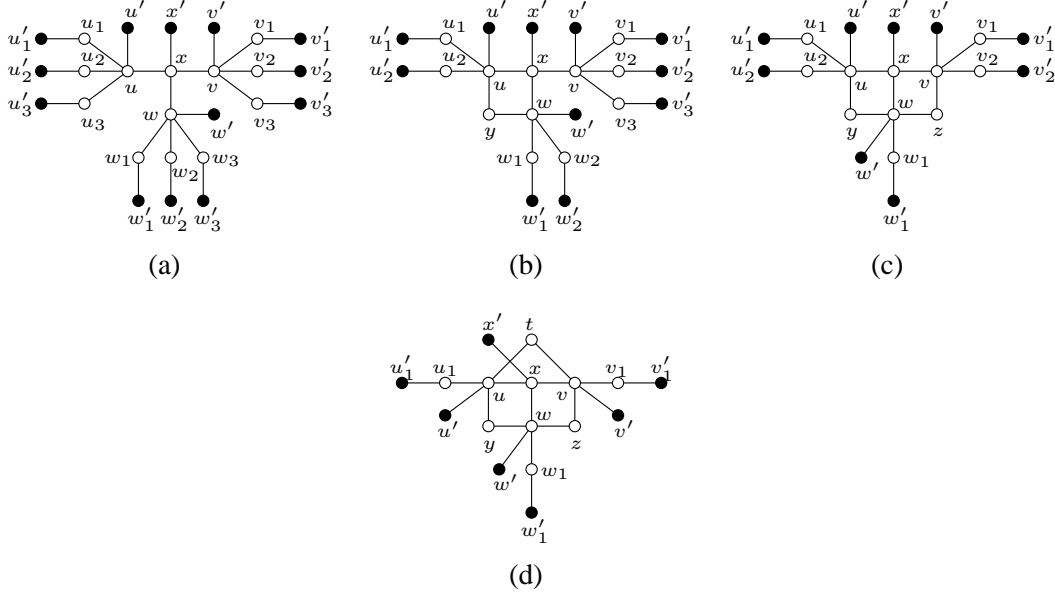

Fig. 11. Configuration (C9): a 4-vertex adjacent to three weak 5-vertices.

Remark 19

- (1) A black vertex cannot coincide with a white vertex at distance at most two since otherwise it would imply either loops or multiple edges.
- (2) A black vertex adjacent to a 2-vertex cannot coincide with a white vertex at distance three, since otherwise it would imply Configuration (C6).
- (3) A black vertex adjacent to a 2-vertex cannot coincide with a white 2-vertex since otherwise it would imply Configuration (C3).
- (4) Let u and v be two white weak 5-vertices sharing a ≥ 3 -neighbor and let u_1, u_2, u_3 be three black ≥ 3 -vertices, each of them sharing a 2-neighbor with u . Then, two u_i 's cannot coincide together with v , since otherwise it would imply Configuration (C7).
- (5) A black vertex adjacent to a weak 5-vertex cannot coincide with a white weak 5-vertex since otherwise it would imply Configuration (C8).

Proof of Configuration (C9). By Remark 19, we just have to prove that the configurations depicted in Figure 11 are forbidden in H to show that H does not contain a 4-vertex adjacent to three weak 5-vertices.

- (a) Suppose that H contains the configuration depicted in Figure 11(a) and let φ be a T_{16} -coloring of H^* . By Lemma 14, each of the weak 5-vertices u, v , and w forbids two colors for x , say f_1, f_2, \dots, f_6 . By Property $P_{1,7}$, we can choose φ such that $\varphi(x) \notin \{f_1, f_2, \dots, f_6\}$.
- (b) Suppose that H contains the configuration depicted in Figure 11(b) and let φ be a T_{16} -coloring of H^* . By Lemma 14, the weak 5-vertex v forbids two colors for x , say f_1, f_2 , and by Lemma 17, the vertices u and w forbid four colors for x , say



Fig. 12. Configuration (C10): a weak 5-vertex adjacent to two weak 4-vertices.

- f_3, \dots, f_6 . By Property $P_{1,7}$, we can choose φ such that $\varphi(x) \notin \{f_1, f_2, \dots, f_6\}$.
- (c) Suppose that H contains the configuration depicted in Figure 11(c) and let φ be a T_{16} -coloring of H^* . By Lemma 16, the vertices u, v and w forbid five colors for x , say f_1, f_2, \dots, f_5 . By Property $P_{1,7}$, we can choose φ such that $\varphi(x) \notin \{f_1, f_2, \dots, f_5\}$.
- (d) Suppose that H contains the configuration depicted in Figure 11(d) and let φ be a T_{16} -coloring of H^* . By Proposition 8, we may assume w.l.o.g. that $\overrightarrow{x'x} \in H$. By Property $P_{1,7}$, the seven color of $N_{T_{16}}^+(\varphi(x'))$ are allowed for x is $H \setminus \{u, u_1, v, v_1, w, w_1, t, y, z\}$. Lemma 18 allows us to conclude.

□

Proof of Configuration (C10). By Remark 19, we just have to prove that the configurations depicted in Figure 12 are forbidden in H to show that H does not contain a weak 5-vertex adjacent to two weak 4-vertices.

- (a) Suppose that H contains the configuration depicted in Figure 12(a) and let $H' = H \setminus \{u, u_1, u_2, u_3, v_1, w_1\}$. Let φ be a T_{16} -coloring of H' . We clearly have $\varphi(v') \neq f_{v'}^\varphi(v'')$ (resp. $\varphi(w') \neq f_{w'}^\varphi(w'')$) since v (resp. w) is colored in H' . Property $P_{2,3}$ insures that we have two available colors for v (resp. w) distinct from $f_v^\varphi(v_1)$ (resp. $f_w^\varphi(w_1)$). Lemma 15 allows us to conclude.
- (b) Suppose that H contains the configuration depicted in Figure 12(b) and let φ be a T_{16} -coloring of H^* . Let $W = \{f_u^\varphi(u_1), f_u^\varphi(u_2), f_u^\varphi(u_3), f_u^\varphi(v'), f_u^\varphi(w')\}$. Remark that we must set $\varphi(u) \notin W$. Therefore, the eleven colors of $V(T_{16}) \setminus W$ are available for u in $H \setminus \{v_1, w_1, vw\}$. W.l.o.g. we may assume that $\overrightarrow{uw} \in H$ by Proposition 8. We choose a color $c_u \in V(T_{16}) \setminus W$ which is not a predecessor of $f_w^\varphi(w_1)$ and we set $\varphi(u) = c_u$. By Property $P_{2,3}$, $\varphi(u)$ together with $\varphi(v')$ allow at least one color c_v for v distinct from $f_v^\varphi(v_1)$ and $f_v^\varphi(w')$; we set $\varphi(v) = c_v$. By Property $P_{3,1}$, we have one color c_w for w and since $\varphi(u)$ is not a predecessor of $f_w^\varphi(w_1)$, we necessarily have $c_w \neq f_w^\varphi(w_1)$. We thus set $\varphi(w) = c_w$.

□



Fig. 13. Configuration (C11): a 5-vertex adjacent to two 2-vertices and two weak 5-vertices.

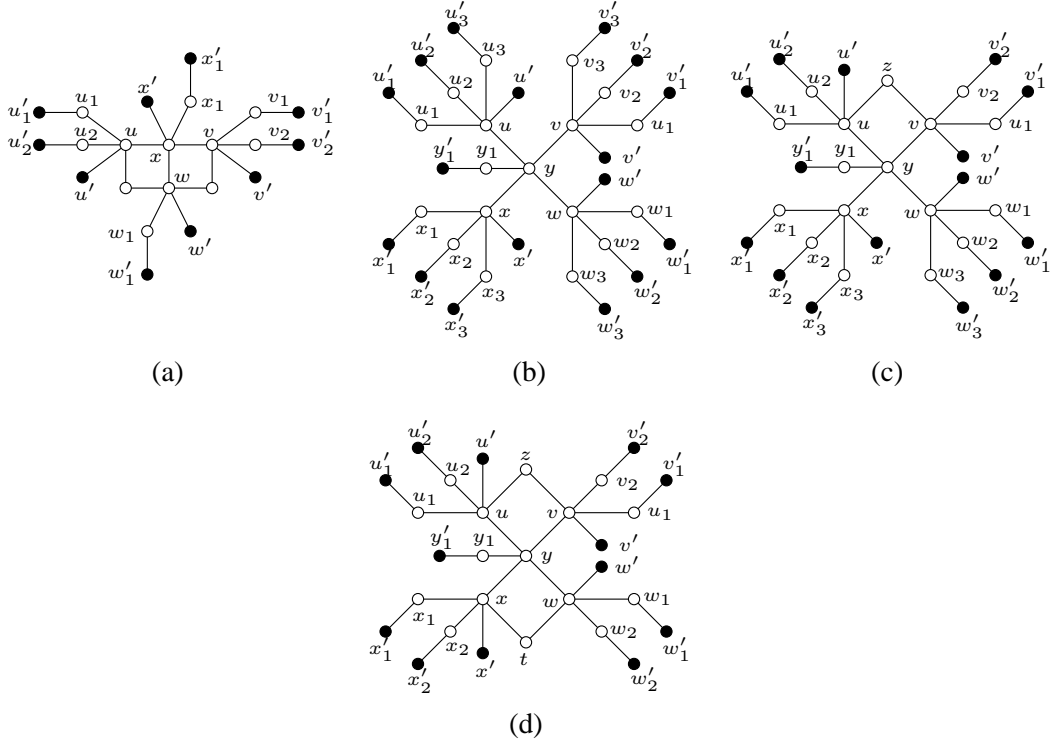

Fig. 14. Configuration (C12): a 5-vertex adjacent to one 2-vertex and four weak 5-vertices.

Proof of Configuration (C11). By Remark 19, we just have to prove that the configurations depicted in Figure 13 are forbidden in H to show that H does not contain a 5-vertex adjacent two 2-vertices and two weak 5-vertices.

Suppose that H contains the configuration depicted in Figure 13(a) (resp. Figure 13(b)) and let φ be a T_{16} -coloring of H^* . The weak 5-vertices u and v forbid four colors for x , say f_1, f_2, f_3, f_4 , by Proposition 14 (resp. Lemma 17). By Property $P_{1,7}$, we can choose φ such that $\varphi(x) \notin \{f_1, f_2, f_3, f_4, f_x^\varphi(x'_1), f_x^\varphi(x'_2)\}$. \square

Proof of Configuration (C12). By Remark 19, we just have to prove that the configurations depicted in Figure 14 are forbidden in H to show that H does not contain a 5-vertex adjacent to one 2-vertices and four weak 5-vertices.

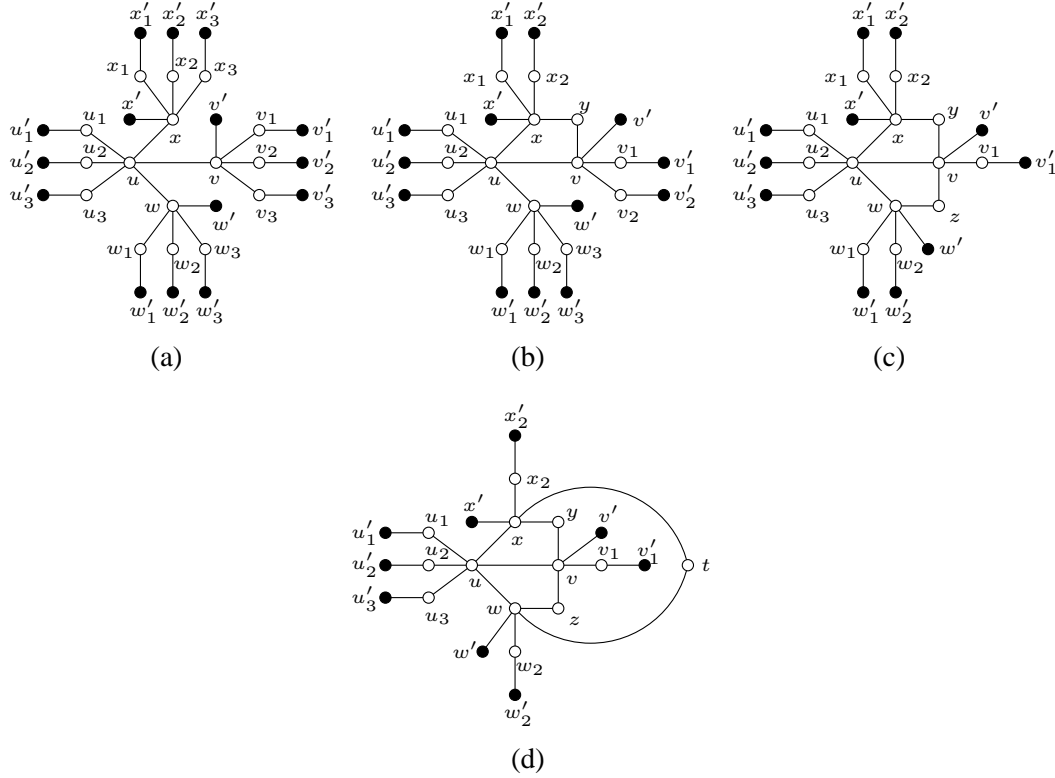

Fig. 15. Configuration (C13): a 6-vertex adjacent to three 2-vertices and three weak 5-vertices.

- (a) Suppose that H contains the configuration depicted in Figure 14(a) and let φ be a T_{16} -coloring of H^* . By Lemma 16, the weak 5-vertices u , v , and w forbid five colors for x , say f_1, \dots, f_5 . By Property $P_{1,7}$, we can choose φ such that $\varphi(x) \notin \{f_1, \dots, f_5, f_x^\varphi(x'_1)\}$.
- (b)(c)(d) Suppose that H contains one of the configurations depicted in Figures 14(b), 14(c), and 14(d) and let φ be a T_{16} -coloring of H^* . By Lemmas 14 and 17, the weak 5-vertices u , v , w , and x forbid eight colors for y , say f_1, \dots, f_8 . We clearly can choose φ such that $\varphi(y) \notin \{f_1, \dots, f_8, f_y^\varphi(y'_1)\}$.

□

Proof of Configuration (C13). By Remark 19, we just have to prove that the configurations depicted in Figure 15 are forbidden in H to show that H does not contain a 6-vertex adjacent to three 2-vertices and three weak 5-vertices.

- (a)(b) Suppose that H contains one of the configurations depicted in Figures 15(a) and 15(b) and let φ be a T_{16} -coloring of H^* . The weak 5-vertices v , w , and x forbid six colors for u , say f_1, \dots, f_6 , by Lemmas 14 and 17. We clearly can choose φ such that $\varphi(u) \notin \{f_1, \dots, f_6, f_u^\varphi(u'_1), f_u^\varphi(u'_2), f_u^\varphi(u'_3)\}$.



Fig. 16. Configuration (C14): a 7-vertices adjacent to five 2-vertices and two weak 5-vertices.

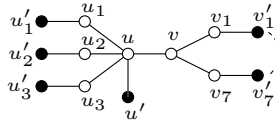

Fig. 17. Configuration (C15): an 8-vertex adjacent to seven 2-vertices and one weak 5-vertex.

- (c) Suppose that H contains the configuration depicted in Figure 15(c) and let φ be a T_{16} -coloring of H^* . The weak 5-vertices v , w , and x forbid five colors for u , say f_1, \dots, f_5 . We clearly can choose φ such that $\varphi(u) \notin \{f_1, \dots, f_5, f_u^\varphi(u'_1), f_u^\varphi(u'_2), f_u^\varphi(u'_3)\}$.
- (d) Suppose that H contains the configuration depicted in Figure 15(d) and let φ be a T_{16} -coloring of H^* . Let $W = \{f_u^\varphi(u'_1), f_u^\varphi(u'_2), f_u^\varphi(u'_3)\}$. Remark first that we must set $\varphi(u) \notin W$. Among the thirteen vertices of $V(T_{16}) \setminus W$, we can check that there exist seven vertices which are the seven successors of some vertex v of T_{16} . Lemma 18 allows us to conclude.

□

Proof of Configuration (C14). By Remark 19, we just have to prove that the configurations depicted in Figure 16 are forbidden in H to show that H does not contain a 7-vertex adjacent to five 2-vertices and two weak 5-vertices.

Suppose that H contains one of the configurations depicted in Figures 16(a) and 16(b) and let φ be a T_{16} -coloring of H^* . The weak 5-vertices v and w forbid four colors for u , say f_1, \dots, f_4 , by Lemmas 14 and 17. We clearly can choose φ such that $\varphi(u) \notin \{f_1, \dots, f_4, f_u^\varphi(u'_1), f_u^\varphi(u'_2), \dots, f_u^\varphi(u'_5)\}$. □

Proof of Configuration (C15). Suppose that H contains the configurations depicted in Figure 17 and let φ be a T_{16} -coloring of H^* . The weak 5-vertex u forbids two colors for v , say f_1, f_2 , by Lemma 14. We clearly can choose φ such that $\varphi(v) \notin \{f_1, f_2, f_v^\varphi(v'_1), f_v^\varphi(v'_2), \dots, f_v^\varphi(v'_7)\}$. \square

3.2 Discharging procedure

To complete the proof of Theorem 4, we use a discharging procedure. We define the weight function ω by $\omega(v) = 3d(v) - 10$ for every $v \in V(H)$. Since $\text{mad}(H) < \frac{10}{3}$, we have:

$$\sum_{v \in V(H)} \omega(v) = \sum_{v \in V(H)} (3d(v) - 10) < 0.$$

In what follows, we will define discharging rules (R1), (R2) and (R3) and redistribute weights accordingly. Once the discharging is finished, a new weight function ω^* is produced. However, the total sum of weights is fixed by the discharging rules. Nevertheless, we can show that $\omega^*(v) \geq 0$ for every $v \in V(H)$. This leads to the following obvious contradiction:

$$0 \leq \sum_{v \in V(H)} \omega^*(v) = \sum_{v \in V(H)} \omega(v) < 0.$$

Therefore, no such counterexample H exists.

The discharging rules are defined as follows:

- (R1) Each weak 4-vertex gives 2 to its 2-neighbor.
- (R2) Each non weak 4-vertex gives 1 to their weak 5-neighbors.
- (R3) Each ≥ 5 -vertex gives 2 to their 2-neighbors and 1 to their weak 5-neighbors.

Let v be a k -vertex of H . Note that $k > 1$ by (C1) and $k \neq 3$ by (C5).

- If $k = 2$, then $\omega(v) = -4$. Since every 2-vertices of H has two ≥ 4 -neighbors by (C2) and (C3), v receives 2 from each neighbor by (R1) and (R3). Hence $\omega^*(v) = 0$.
- If $k = 4$, then $\omega(v) = 2$. By (C2), a 4-vertex has at most one 2-neighbor. If v has one 2-neighbor (i.e. v is weak), then it gives 2 by (R1). If v has no 2-neighbor, then it has at most two weak 5-neighbors by (C9). Therefore, v gives at most 1×2 by (R2). Hence $\omega^*(v) \geq 2 - \max\{2; 1 \times 2\} = 0$.
- If $k = 5$, then $\omega(v) = 5$. By (C3), a 5-vertex has at most three 2-neighbors. If v has three 2-neighbors (i.e. v is weak), then it has no weak 5-neighbors by (C8); it thus gives 2×3 by (R3). Moreover, by (C10), v has at most one weak 4-neighbor; therefore, v has at least either one non weak 4-neighbor or one ≥ 5 -neighbor; thus, v receives at least 1 by (R2) or (R3). If v has two 2-neighbors, then it has at most one weak 5-neighbor by (C11), and then gives at most $2 \times 2 + 1$ by (R3). If v has

- one 2-neighbor, then it has at most three weak 5-neighbors by (C12), and then gives at most $2 + 1 \times 3$ by (R3). Finally, if v has no 2-neighbor, it gives at most 1×5 by (R3). Hence, $\omega^*(v) \geq 5 - \max\{2 \times 3 - 1; 2 \times 2 + 1; 2 + 1 \times 3; 1 \times 5\} = 0$.
- If $k = 6$, then $\omega(v) = 8$. By (C3), a 6-vertex has at most four 2-neighbors. If v has four 2-neighbors, then it has no weak 5-neighbor by (C8), and then gives 2×4 by (R3). If v has three 2-neighbors, then it has at most two weak 5-neighbors by (C13), and then gives at most $2 \times 3 + 1 \times 2$ by (R3). Finally, if v has l 2-neighbors, $0 \leq l \leq 2$, then v has at most $(6 - l)$ weak 5-neighbors and then gives at most $2 \times l + 1 \times (6 - l)$ by (R3). Hence, $\omega^*(v) \geq 8 - \max\{2 \times 4; 2 \times 3 + 1 \times 2; 2 \times l + 1 \times (6 - l)\} = 0$ for any $0 \leq l \leq 2$.
 - If $k = 7$, then $\omega(v) = 11$. By (C3), a 7-vertex has at most five 2-neighbors. If v has five 2-neighbors, then it has at most one weak 5-neighbor by (C14) and then gives at most $2 \times 5 + 1$ by (R3). Finally, if v has l 2-neighbors, $0 \leq l \leq 4$, then it has at most $(7 - l)$ weak 5-neighbors and then gives at most $2 \times l + 1 \times (7 - l)$ by (R3). Hence, $\omega^*(v) \geq 11 - \max\{2 \times 5 + 1; 2 \times l + 1 \times (7 - l)\} = 0$ for any $0 \leq l \leq 4$.
 - If $k = 8$, then $\omega(v) = 14$. By (C4), an 8-vertex has at most seven 2-neighbors. If v has seven 2-neighbors, then it has no weak 5-neighbor by (C15) and then gives 2×7 by (R3). Finally, if v has l 2-neighbors, $0 \leq l \leq 6$, then it has at most $(8 - l)$ weak 5-neighbors and then gives at most $2 \times l + 1 \times (8 - l)$ by (R3). Hence, $\omega^*(v) \geq 14 - \max\{2 \times 7; 2 \times l + 1 \times (8 - l)\} = 0$ for any $0 \leq l \leq 6$.
 - If $k = 9$, then $\omega(v) = 17$. By (C4), a 9-vertex has at most eight 2-neighbors. If v has l 2-neighbors, $0 \leq l \leq 8$, then it has at most $(9 - l)$ weak 5-neighbors and then gives at most $2 \times l + 1 \times (9 - l)$ by (R3). Hence, $\omega^*(v) \geq 17 - 2 \times l + 1 \times (9 - l) \geq 0$ for any $0 \leq l \leq 8$.
 - If $k \geq 10$, then $\omega(v) = 3k - 10$. If v has l 2-neighbors, $0 \leq l \leq k$, then v has at most $(k - l)$ weak 5-neighbors and then gives at most $2 \times l + 1 \times (k - l)$ by (R3). Hence, $\omega^*(v) \geq 3k - 10 - 2 \times l + 1 \times (k - l) \geq 0$ for any $0 \leq l \leq k$.

Thus, for every $v \in V(H)$, we have $\omega^*(v) \geq 0$ once the discharging is finished, that completes the proof.

4 Concluding remarks

In 1999, Nešetřil and Raspaud [9] introduced the notion of *strong oriented coloring*, which is a stronger version of the notion of oriented coloring studied in this paper.

Let M be an additive abelian group. An *M -strong-oriented coloring* of an oriented graph G is a mapping φ from $V(G)$ to M such that $\varphi(u) \neq \varphi(v)$ whenever \vec{uv} is an arc in G and $\varphi(v) - \varphi(u) \neq -(\varphi(t) - \varphi(z))$ whenever \vec{uv} and \vec{zt} are two arcs in G . The *strong oriented chromatic number* of an oriented graph is the minimal order of a group M such that G has an M -strong-oriented coloring. It is clear that any strong oriented coloring of an oriented graph G is an oriented coloring of G

and therefore the oriented chromatic number of G is less than its strong oriented chromatic number.

Nešetřil and Raspaud showed that a strong oriented coloring of an oriented graph G can be equivalently defined as a homomorphism ϕ from G to H , where H is an oriented graph with k vertices labeled by the k elements of an abelian additive group M , such that for any pair of arcs \vec{uv} and \vec{zt} of $A(H)$, $v - u \neq -(t - z)$. For every prime power $p \equiv 3 \pmod{4}$, the Paley graph QR_p (defined in Section 2, page 4) is clearly an oriented graph with p vertices labeled by the p elements of the field $\frac{\mathbb{Z}}{p\mathbb{Z}}$ and such that for any pair of arcs \vec{uv} and \vec{zt} of $A(QR_p)$, $v - u \neq -(t - z)$.

Let G be an oriented graph with $\text{mad}(G) < \frac{10}{3}$. Borodin et al. [4] proved that the oriented chromatic number of every such graph G is at most 19. In this paper, we improved this result by showing that 16 colors are enough. However, to prove their result, Borodin et al. showed that every such graph G admits a homomorphism to the Paley graph QR_{19} . Therefore, their result is stronger: every graph with maximum average degree strictly less than $\frac{10}{3}$ has a *strong* oriented chromatic number at most 19. So, a natural question to ask is:

Question 20 *Does there exist an abelian additive group M on 16 elements such that we can label the vertices of T_{16} with the elements of M in such a way that $v - u \neq -(t - z)$ whenever \vec{uv} and \vec{zt} are two arcs of T_{16} ?*

If it is true, that would imply that 16 colors are enough for a *strong* oriented coloring of an oriented graph with maximum average degree strictly less than $\frac{10}{3}$.

Acknowledgements

I am deeply grateful to Pascal Ochem for his helpful comments.

References

- [1] O. V. Borodin and A. O. Ivanova. An oriented 7-colouring of planar graphs with girth at least 7. *Sib. Electron. Math. Reports*, 2:222–229, 2005.
- [2] O. V. Borodin and A. O. Ivanova. An oriented colouring of planar graphs with girth at least 4. *Sib. Electron. Math. Reports*, 2:239–249, 2005.
- [3] O. V. Borodin, A. O. Ivanova, and A. V. Kostochka. Oriented 5-coloring of sparse plane graphs. *J. Applied and Industrial Mathematics*, 1(1):9–17, 2007.

- [4] O. V. Borodin, A. V. Kostochka, J. Nešetřil, A. Raspaud, and É. Sopena. On the maximum average degree and the oriented chromatic number of a graph. *Discrete Math.*, 206:77–89, 1999.
- [5] B. Courcelle. The monadic second order-logic of graphs VI : on several representations of graphs by relational structures. *Discrete Appl. Math.*, 54:117–149, 1994.
- [6] P. Hell and J. Nešetřil. *Graphs and homomorphisms*, volume 28 of *Oxford Lecture Series in Mathematics and its Applications*. Oxford University Press, 2004.
- [7] A. V. Kostochka, É. Sopena, and X. Zhu. Acyclic and oriented chromatic numbers of graphs. *J. Graph Theory*, 24:331–340, 1997.
- [8] T. H. Marshall. Homomorphism bounds for oriented planar graphs. *J. Graph Theory*, 55(3):175–190, 2007.
- [9] J. Nešetřil and A. Raspaud. Antisymmetric flows and strong colourings of oriented graphs. *Annales de l'Institut Fourier*, 49:1037–1056, 1999.
- [10] P. Ochem. Oriented colorings of triangle-free planar graphs. *Inform. Process. Lett.*, 92:71–76, 2004.
- [11] A. Raspaud and É. Sopena. Good and semi-strong colorings of oriented planar graphs. *Inform. Process. Lett.*, 51(4):171–174, 1994.
- [12] É. Sopena. The chromatic number of oriented graphs. *J. Graph Theory*, 25:191–205, 1997.
- [13] É. Sopena. Oriented graph coloring. *Discrete Math.*, 229(1-3):359–369, 2001.
- [14] J. Tromp. Unpublished manuscript.
- [15] D. R. Wood. Acyclic, star and oriented colourings of graph subdivisions. *Discrete Math. Theoret. Comput. Sci.*, 7(1):37–50, 2005.