



**HAL**  
open science

# An Efficient Data-hiding Method Based on Lossless JPEG2000 for a Scalable and Synchronized Visualization of 3D Terrains

Khizar Hayat, William Puech, Gilles Gesquière

► **To cite this version:**

Khizar Hayat, William Puech, Gilles Gesquière. An Efficient Data-hiding Method Based on Lossless JPEG2000 for a Scalable and Synchronized Visualization of 3D Terrains. EUSIPCO: European Signal Processing Conference, Sep 2007, Poznan, Poland. pp.2519-2523. lirmm-00192602

**HAL Id: lirmm-00192602**

**<https://hal-lirmm.ccsd.cnrs.fr/lirmm-00192602>**

Submitted on 28 Nov 2007

**HAL** is a multi-disciplinary open access archive for the deposit and dissemination of scientific research documents, whether they are published or not. The documents may come from teaching and research institutions in France or abroad, or from public or private research centers.

L'archive ouverte pluridisciplinaire **HAL**, est destinée au dépôt et à la diffusion de documents scientifiques de niveau recherche, publiés ou non, émanant des établissements d'enseignement et de recherche français ou étrangers, des laboratoires publics ou privés.

# AN EFFICIENT DATA-HIDING METHOD BASED ON LOSSLESS JPEG2000 FOR A SCALABLE AND SYNCHRONIZED VISUALIZATION OF 3D TERRAINS

K. Hayat <sup>a</sup>, W. Puech <sup>a</sup> and G. Gesquiere <sup>b</sup>

<sup>a</sup> LIRMM Laboratory, UMR CNRS 5506, University of Montpellier II  
161, rue Ada, 34392 MONTPELLIER CEDEX 05, FRANCE

<sup>b</sup> LSIS Laboratory, UMR CNRS 6168, Aix-Marseille University  
IUT, rue R. Follereau, 13200 ARLES, FRANCE

khizar.hayat@lirmm.fr, william.puech@lirmm.fr, gilles.gesquiere@lsis.org

## ABSTRACT

*Real-time on-line 3D visualization of terrain is a memory intensive process accompanied by considerably large data transfer across the network and thus data compression is inevitable. The upcoming standard of JPEG2000 is well suited for such network based transfers since it offers the additional advantage of resolution scalability resulting in incremental improvement of quality. The 3D visualization process is, essentially, the linking of the texture image with the terrain geometry obtained from DEM; the data are heterogeneous and normally involves more than one file. This work is concerned with the interleaving of these files into one jp2 file in a synchronized way so that the file format is conserved for compliance to the JPEG2000 standard. This synchronization is achieved by using a scalable data hiding method to embed the lossless wavelet transformed DEM in the corresponding lossless JPEG2000 coded texture. For the DEM and the texture, the level of transform is the same. With this approach the 3D visualization is efficient even if a small fraction of the initial data is transmitted.*

## 1. INTRODUCTION

With the incredible technological advancement of the past few years, both the spatial and temporal requirements of the 3D terrain visualization have grown considerably. Processing powers and memory sizes as well as network speeds and bandwidths have also increased considerably. But at the same time the users are becoming more and more demanding in terms of visualization quality. It is currently possible to have aerial/satellite images with an accuracy as high as 0.50 meter per pixel, and even more, but with a storage cost. The problem is exacerbated when it comes to real-time visualization where the data have to be transferred from a server to a client application. The diversity of clients in terms of network, computation and memory resources add another facet to the problem, since a client may, for instance, have lower capacity of handling the real-time data and it would have to receive a coarser data. The last problem but not the least is the increased demand for higher accuracy that implies a finer resolution. All these factors necessitate the setting up of some strategy based on a multi-resolution approach. The upcoming standard of JPEG2000 [3] serves this purpose since it is wavelet based which offers the property of resolution scalability that is most suited to the solution of our problem.

As far as the visualization in three dimensions is concerned, it is important to link the images of the terrain, called textures, with the geometry of the terrain computed with the digital elevation model (DEM). This linking is possible by

geo-referencing the coordinates (longitude/latitude) of these elements and define the scale and the projection system used. All these informations are in general stored in three different files: DEM, texture and system of geo-referencing employed. One would be better off if these files are combined into a single one. There are solutions like GeoJP2 [2] and GMLJP2 [8] but these serve the purpose partially since the data is not synchronized and there is an increase in the original size of the jp2 file. We follow a different course, to have the advantage of synchronization without any change in the jp2 file size, by applying a scalable data hiding algorithm. Neither our approach is XML based, like GMLJP2, nor do we introduce some kind of UUID boxes, like GeoJP2.

We intend to visualize, on a client application, a terrain defined by the given elevations and their corresponding texture whereby the data is stored on a distant server and is sent in small-sized packets in order to minimize the waiting time. Our objective is to store and synchronize all of this information in only one file in order to develop a client-server application for 3D real-time visualization. The approach is to utilize discrete wavelet transformation (DWT) to decompose the 3D information at various resolution levels and to embed the resulting data in the related image which is itself decomposed at different resolution levels. From this approach it is possible to transmit only one file containing all the information and at the reception only a fraction of the data should be sufficient for an optimal or near-optimal visualization. In order to store all the information in a single file, without developing any new proprietary format and maintaining compressions performances, we propose in this paper the use of a JPEG2000 based embedding method for data hiding. The peculiarity of our method is the synchronization achieved by dynamically linking the wavelet transformed DEM with the corresponding wavelet transformed aerial image keeping in view the resolution scalability characteristic of the JPEG2000 format.

## 2. PREVIOUS WORK

There are already efforts like GeoJP2 and GMLJP2 for the integration of geographical data with the related aerial photographs. The GeoJP2 is a GeoTIFF-based method for adding geospatial meta-data to a JPEG2000 file. The additions made to the box-based jp2 format are two UUID boxes, namely, the GeoTIFF box and the optional world file box. The former contains a degenerate GeoTIFF file and the resultant jp2 file have the same level of geospatial meta-data as is provided by the GeoTIFF standard [2]. The mechanism is simple using the widely supported GeoTIFF implementa-

tions but the introduction of new UUID boxes have the disadvantage that there is an increase in the original jp2 file size. The GMLJP2 envisages the use of the Geography Markup Language (GML) within the XML boxes of the JPEG 2000 data format in the context of geographic imagery. In [8], a minimally required GML definition is specified for georeferencing images while also giving guidelines for encoding of meta-data, features, annotations, styles, coordinate reference systems, and units of measure as well as packaging mechanisms for both single and multiple geographic images. Digital Elevation Models are treated the same way as other image use cases whereas coordinate reference system definitions are employed using a dictionary file. Thus DEM is either provided as TIFF file and it's name is inserted between proper GML tags or its points are directly inserted into the GMLJP2 file. In the former case there is no reduction in the number of files whereas in the latter case the amount of data is increased.

Many methods have been proposed in the literature for wavelet-based data hiding but few of these are compatible with the JPEG2000 scheme. According to Meerwald and Uhl [12], data hiding methods for JPEG2000 images must process the code blocks independently and that is why methods like inter-subband embedding [5] and those based on hierarchical multi-resolution relationship [7] have not been recommended. In the same breath he rejects the correlation-based method [15] as well as non-blind methods for the reason of limited number of coefficients in a JPEG2000 code-block that are likely to fail in reliably detecting the hidden information in a single independent block. There are methods [16, 6] of embedding invisible watermarks by adding pseudo-random codes to large coefficients of the high and middle frequency bands of DWT but these methods have the disadvantage of being non-blind. The blind scheme proposed in [14] is to integrate data hiding with the EBCOT (Embedded Block Coding with Optimized Truncation) and embed data during the formation of compressed bit stream. The scheme is claimed to have robustness and good perceptual transparency. One particular technique [11] embed watermark in the JPEG2000 pipeline after the stages of quantization and ROI scaling but before the entropy coding. For reliability purposes the finest resolution subbands are avoided. A window sliding approach is adopted for embedding with the lowest frequencies having higher payload. Piva *et al.* [13] has proposed the embedding of image digest in a DWT based authentication scheme where the date is inserted in the layers containing the meta-data. One blind method [9] transforms the original image  $X$  by one-level wavelet transform and sets the three higher subbands to zero before inverse transforming it to get the reference image  $Y$ . The difference values between  $X$  and  $Y$  are used to ascertain the potential embedding locations of which a subset is selected randomly for embedding. The method of Kong *et al.* [4] embeds watermark in the weighted mean of the wavelets blocks, rather than in the individual coefficient, to make it robust and perceptually transparent.

### 3. THE METHOD

The data are generally stored in three different files: the DEM, the texture and the coordinate and projection system employed. In order to store all of these informations in a single file we propose in this paper to embed the DEM in the

texture in a synchronized and scalable way. An information of altitude is thus synchronized with the corresponding pixel block of the texture. We choose to use JPEG2000 format in order to fully exploit the property of multilevel resolution for scalability purposes. The implementation of the discrete wavelet transformation (DWT) of the DEM is based on the lifting method [10] that employs the JPEG2000 supported reversible Daubechies (5/3) [1].

In order to embed the altitude information in the texture map, we propose to follow the protocol illustrated in Figure 1. From a  $N^2$  pixel texture image and the corresponding map of  $m^2$  altitudes, we deduce the embedding factor  $E = m^2/N^2$  coefficients per pixel. The image of texture will, therefore, have to be divided into square blocks of size equal to  $\lceil 1/E \rceil$  pixels and every such block would hide one altitude coefficient. The wavelet transformed Y component of the texture image is extracted from the JPEG2000 pipeline of the openjpeg encoder in the first place. A discrete wavelet transformation (DWT) is then separately applied to the corresponding altitude map. The type of transformation employed in both cases is reversible Daubechies(5/3) with the same level of wavelet decomposition.

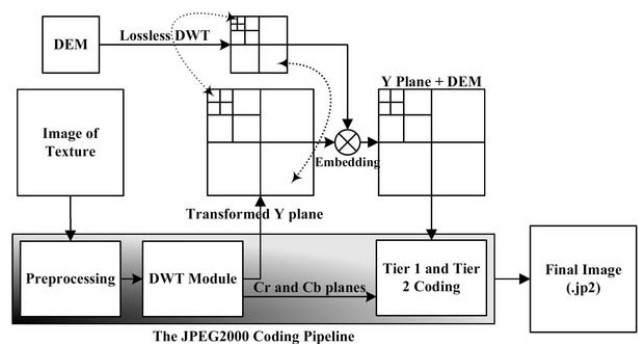

Figure 1: Description of the method: embedding DWTEd DEM coefficients in the DWTEd coefficients of the texture.

To ensure a spatial coherence between the altitudes and the texture, the luminance plane  $Y$  in the wavelet domain, at a particular resolution level  $L$ , is virtually divided into square blocks of  $\lceil 1/E \rceil$  coefficients for data embedding. In each block we embed one information of altitude at the same level  $L$  of decomposition. We thus achieve a synchronization in the embedding as far as the incremental levels of the wavelets are concerned, i.e. low resolution coefficients of the altitude map are embedded in the low resolution sub-bands of texture whereas high resolution coefficients of the altitude map are embedded in the high resolution sub-bands. In this way the transmission of the part concerned with the low resolution of the texture map enables us to directly access the corresponding low resolution part of the altitude map. The data embedding is carried out by modifying the least significant bits of a certain number of coefficients of the luminance plane of the texture. These coefficients are chosen by using a pseudo random number generator (PRNG) with a key,  $K$ , as a seed. The resultant carrier image, i.e. altered  $Y$  plane of the texture in the wavelet domain, is then re-inserted into the JPEG2000 pipeline at the same point from where extracted. The final encoded image (.jp2) thus carries the DEM coefficients hidden in some DWT coefficients. When such a

code is sent across any communication channel, the resolution scalability of wavelets and the synchronized character of our method enable a 3D visualization even with fewer than original resolution layers as a result of partial or delayed data transfer. The method is blind and rather than the original texture image, only the (PRNG) key  $K$  is needed to recover the hidden DEM coefficients. This method would enable us to effect a visualization from a fraction of data in the form of the lowest subband, of a particular resolution level. It is always possible to stuff 0's for the higher bands. The idea is to have a 3D visualization utilizing  $3L' + 1$  parts out of the initial  $3L + 1$  parts ( $L' \leq L$ ), by stuffing the rest of  $L - L'$  parts with 0's.

#### 4. RESULTS



Figure 2: Example images; a) altitude, b) Texture, c) A part of texture magnified.

We have applied our method to a  $3200 \times 3200$  pixel tex-

ture image, illustrated in Figure 2.b, with the associated altitude map of  $64 \times 64$  coefficients, illustrated in Figure 2.a. For the purpose of comparison a  $128 \times 128$  pixel detail of the above mentioned image of texture is presented in Figure 2.c. Each coefficient of the altitude is coded with 2 bytes implying the embedding factor of 1 coefficient per  $50 \times 50$  pixels of texture.

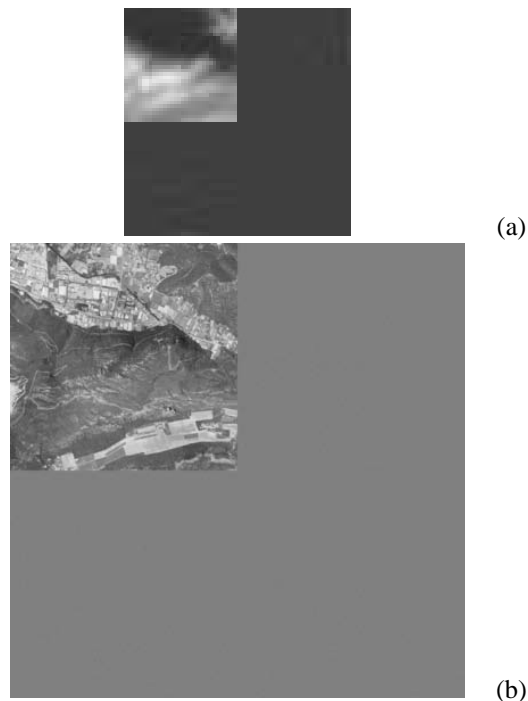

Figure 3: DWT at Level 1; a) altitude, b) Y Plane of texture.

By applying lossless wavelet transformation to the map of altitudes we obtained the results illustrated in Figures 3 for level 1 transformation. The corresponding transformed Y-plane of the texture image is shown in Figure 3.b. For the DWT at level 1, Figure 3.a, the embedding has been done in four parts (LL, LH, HL and HH) whereas for level 3, wavelet decomposition the embedding of data has been realized in ten parts. Hence, in general, the data embedding at level  $L$  decomposition takes place in  $3L + 1$  parts. No matter what is the level of decomposition, the difference between the texture image before and after data embedding gave us a mean square error (MSE) of 0.01 corresponding to a PSNR of  $68.5 \text{ dB}$  since one 16 bit coefficient of the altitude are embedded per  $50 \times 50$  block of coefficients of the Y component of texture giving a meager embedding factor of  $6.4 \times 10^{-3}$ .

Figure 4.a shows an altitude map reconstructed from the coefficients extracted from a level 1 image of approximation (LL) of the embedded texture image. The reconstruction has been done by stuffing 0's in place of the three higher subbands and applying inverse DWT to the resulting four subbands. Thus only 25% of the initial coefficients have been used for reconstruction. The difference of this image with the original altitude resulted in Figure 4.b. When the above process of reconstruction is applied to the level 1 lowest subband of the embedded texture image Figure 4.c is obtained. For comparison with the original example, the  $128 \times 128$  pixel magnified part is shown in Figure 4.d. The corresponding

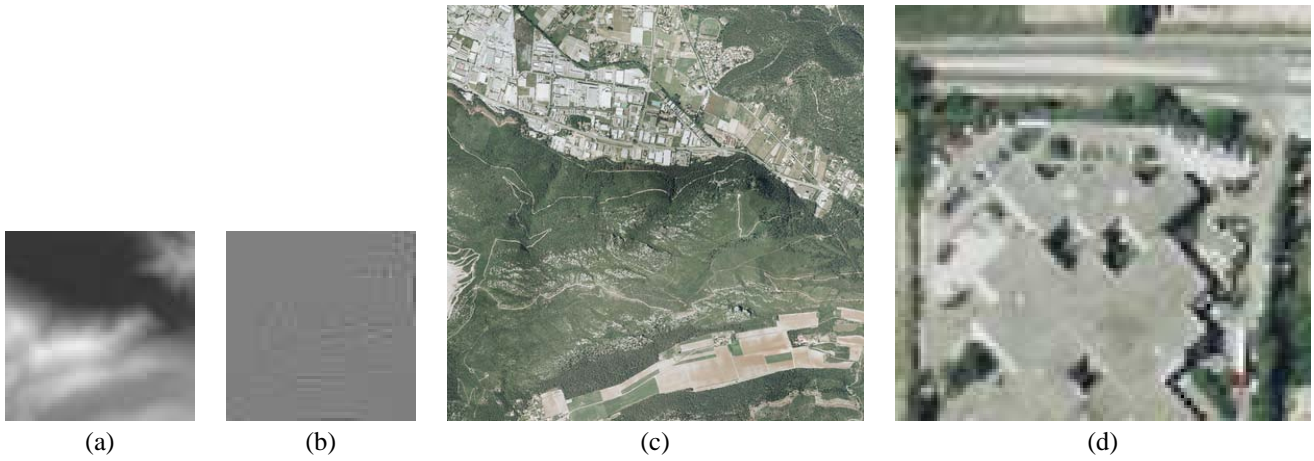

Figure 4: Reconstruction of the images from the approximation image at Level 1; a) Extracted altitude, b) Difference image of altitude, c) Texture, d) Magnified Part of texture corresponding to Figure 2.

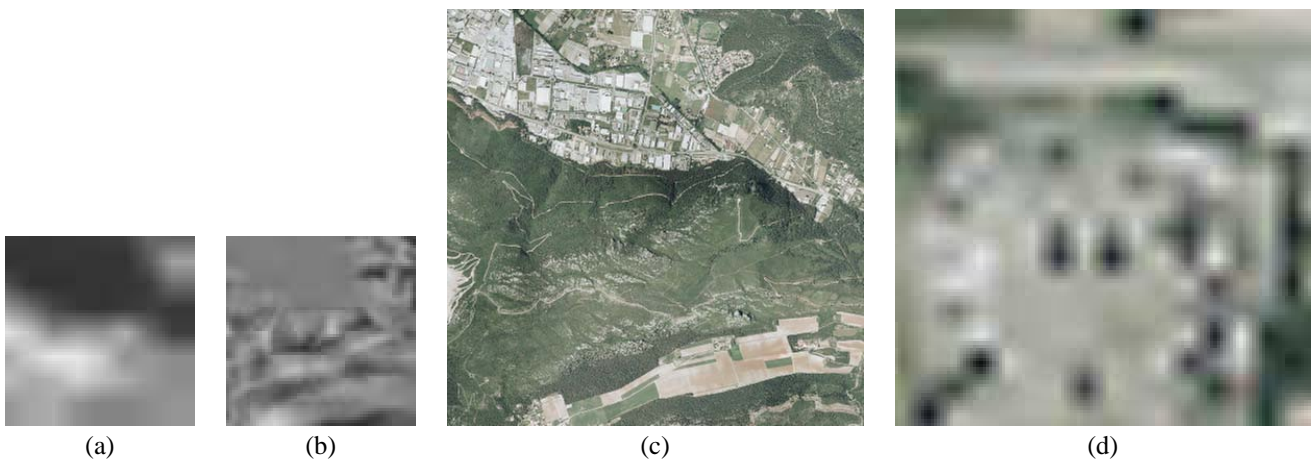

Figure 5: Reconstruction of the images from the approximation image at Level 3; a) Extracted altitude, b) Difference image of altitude, c) Texture, d) Magnified Part of texture corresponding to Figure 2.

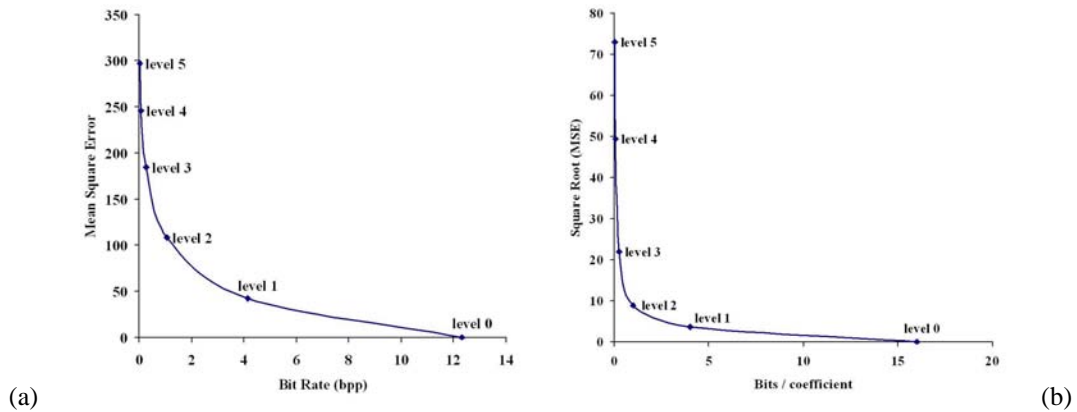

Figure 6: Graphs a) Texture, b) DEM.

images for a level 3 reconstruction, i.e with 1.56% of the initial coefficients, are illustrated in Figure 5. For the subjective analysis of quality, one can visually compare the parts *d* of Figures 2, 4 and 5, respectively; there is surely degradation in the visual quality but it is far more less than reduction in

the quantity of data.

Objectivity demands a quantitative comparison which we have done in terms of the images of difference by observing the measures, like MSE or PSNR, as a function of compression rate. To elaborate further, MSE has been plotted as a



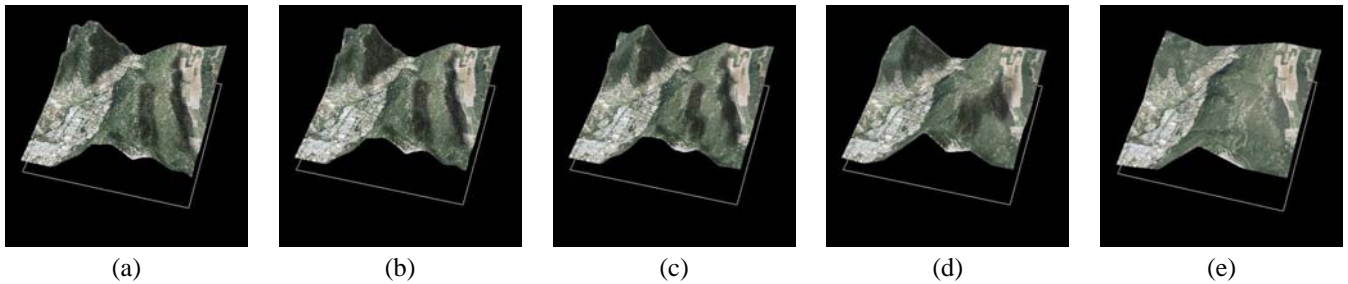

Figure 7: 3D visualization with the images of approximation of a) Level 0(all the data), b) Level 1, c) Level 2, d) Level 3, e) Level 4.

function of bit rate for the texture (Figure 6.a.) and as a function of bits per coefficient for DEM (Figure 6.b). In the latter case we have plotted MSE against bits per coefficient due to the fact that rather than the whole JPEG2000 encoding only DWT has been applied to the DEM coefficients. The effectiveness of our method is revealed by the fact that even for a compression rate as low as 0.26 *bpp* (corresponds to level 3 approximation image of texture) one observes a *MSE* of 184.56 corresponding to a *MSE* for DEM that has a square root of 22.02 *m* during visualization. Given the fact that being computed from a small fraction of initial data, this error is tolerable if the observation is made from a very high altitude. As can be seen in Figure 6.a. the *MSE* decreases as further levels of information are added to the image of approximation, e.g for 1.06 *bpp* (level 2) the *MSE* is 107.97 and for 4.14 *bpp* (level 1) the *MSE* is 42.01. A similar trend is observed in case of  $\sqrt{MSE}$  for the DEM (Figure 6.b).

By mapping the texture onto the corresponding DEM a 3D visualization is effected. One can compare the final result between a visualization with all the data (Figure 7.a) and a visualization with the level 1, 2, 3 and 4 (Figure 7.b–e), corresponding to 25%, 6.25%, 1.56% and 0.39% of the transmitted coefficients, respectively.

## 5. CONCLUSION

The data hiding based synchronization process described in this paper is cost effective in terms of memory and bandwidths. The results shown in the case of our example are witness to this fact since even with a tiny fraction of coefficients a comparatively better visualization was effected. The resolution scalability of wavelets enables this visualization to improve incrementally with the reception of higher frequencies/subbands. Besides, this property is helpful in real-time environment when quicker transfer of data is required. The integrability of our method with the JPEG2000 encoders, like openjpeg, means that there is no need to develop any additional technology or data format, thus implying portability and conformance.

## REFERENCES

- [1] I. Daubechies and W. Sweldens. Factoring Wavelet Transforms into Lifting Steps. *Fourier Anal. Appl.*, 4(3), 1998.
- [2] M. P. Gerlek. *The "GeoTIFF Box" Specification for JPEG 2000 Metadata - DRAFT version 0.0*. LizardTech, Inc. 1008 Western Ave Suite 200 Seattle, WA 98104 USA, April 2004.
- [3] ISO/IEC. *ISO/IEC 15444-1: Information technology, JPEG2000 image coding system, Part 1: Core coding system*. 2000.
- [4] X. Kong, Y. Liu, H. Liu, and D. Yang. Object Watermarks for Digital Images and Video. *Image and Vision Computing*, 22:583–595, 2004.
- [5] D. Kundur. Improved Digital Watermarking Through Diversity and Attack Characterization. In *Proc. ACM Workshop on Multimedia Security'99, Orlando, FL, USA*, pages 53–58, Oct 1999.
- [6] D. Kundur and D. Hatzinakos. A Robust Digital Image Watermarking Scheme Using the Wavelet-Based Fusion. In *Proc. IEEE Int. Conf. on Image Processing*, Santa Barbara, California, October 1997.
- [7] D. Kundur and D. Hatzinakos. Digital Watermarking Using Multiresolution Wavelet Decomposition. In *International Conference on Acoustic, Speech and Signal Processing (IEEE ICASP 98)*, volume 5, pages 2969–2972, Seattle, Washington, U.S.A., May 1998.
- [8] R. Lake, D. Burggraf, M. Kyle, and S. Forde. *GML in JPEG 2000 for Geographic Imagery (GMLJP2) Implementation Specification*. Number OGC 05-047r2. Open Geospatial Consortium (OGC), 2005.
- [9] J.-L. Liu, D.-C. Lou, M.-C. Chang, and H.-K. Tso. A Robust Watermarking Scheme Using Self-Reference Image. *Computer Standards & Interfaces*, 28:356–367, 2006.
- [10] S. Mallat. *A Wavelet Tour of Signal Processing*. Academic Press, 1998.
- [11] P. Meerwald. Quantization watermarking in the JPEG2000 coding pipeline. In *Communications and Multimedia Security Issues of The New Century, IFIP TC6/TC11 Fifth Joint Working Conference on Communications and Multimedia Security, CMS '01*, pages 69–79, Darmstadt, Germany, May 2001. Kluwer Academic Publishing.
- [12] P. Meerwald and A. Uhl. A Survey of Wavelet-domain Watermarking Algorithms. In *Proc. of SPIE, Electronic Imaging, Security and Watermarking of Multimedia Contents III*, volume 4314, San Jose, CA, USA, January 2001. SPIE, IS&T.
- [13] A. Piva, F. Bartolini, and R. Caldelli. Self Recovery Authentication of Images in The DWT Domain. *Int. J. Image Graphics*, 5(1):149–166, 2005.
- [14] P.-C. Su, H.-J. Wang, and C.-C. J. Kuo. An Integrated Approach to Image Watermarking and JPEG-2000 Compression. *Journal of VLSI Signal Processing Systems, Special issue on multimedia signal processing*, 27(1-2):35–53, June 1997.
- [15] H.-J. Wang and C.-C.J. Kuo. An Integrated Approach to Embedded Image Coding and Watermarking. In *IEEE ICASSP*, Seattle, WA, USA, 1998.
- [16] X.-G. Xia, C.-G. Boncelet, and G.R. Arce. A multiresolution Watermark for Digital Images. In *Proc. IEEE Int. Conf. on Image Processing*, 1997.