



HAL
open science

Low-Noise Averaging Amplifier Dedicated to ENG Recording with Hexagonal Cuff Electrode

Lionel Gouyet, Guy Cathébras, Serge Bernard, Fabien Soulier, David
Guiraud, Yves Bertrand

► **To cite this version:**

Lionel Gouyet, Guy Cathébras, Serge Bernard, Fabien Soulier, David Guiraud, et al.. Low-Noise Averaging Amplifier Dedicated to ENG Recording with Hexagonal Cuff Electrode. NEWCAS-TAISA 2008 - 2008 Joint 6th International IEEE Northeast Workshop on Circuits and Systems and TAISA Conference, Jun 2008, Montreal, Quebec, Canada. pp.161-164, 10.1109/NEWCAS.2008.4606346 . lirmm-00336369

HAL Id: lirmm-00336369

<https://hal-lirmm.ccsd.cnrs.fr/lirmm-00336369>

Submitted on 7 Sep 2022

HAL is a multi-disciplinary open access archive for the deposit and dissemination of scientific research documents, whether they are published or not. The documents may come from teaching and research institutions in France or abroad, or from public or private research centers.

L'archive ouverte pluridisciplinaire **HAL**, est destinée au dépôt et à la diffusion de documents scientifiques de niveau recherche, publiés ou non, émanant des établissements d'enseignement et de recherche français ou étrangers, des laboratoires publics ou privés.

Low-noise Averaging Amplifier Dedicated to ENG Recording with Hexagonal Cuff Electrode

Lionel Gouyet, Guy Cathébras, Serge Bernard, Fabien Soulier, David Guiraud and Yves Bertrand
LIRMM, Université Montpellier II - CNRS - INRIA, 161 rue Ada, 34392 Montpellier, France
Email: lastname@lirmm.fr

Abstract – In the case of spinal cord injury, Functional Electrical Stimulation, which creates artificial muscle contractions by electrical stimulation, has proven to be capable of helping to restore impaired biological functions. Sensory information from natural sensors going through afferent nervous fibers could be used as feedback information in a closed-loop FES system. In order to get this information, we propose a new multipolar cuff electrode with hexagonal patterns as well as first elements of signal processing and amplification. The hexagonal cuff electrode presented in this paper allows higher sensitivity and a better rejection of parasitic signals than a classical tripolar cuff electrode. The preamplifier associated with this electrode presents the asset to integrate, at the transistor levels, a rejection technique of parasitic signals based on the average. This technique is used to perform electroneurogram (ENG) recording. This integration at the transistor level allows us to reduce the noise level due to processing electronics during sensory information acquisition.

I. INTRODUCTION

Since the nervous system is the centre of communication and regulation inside the organism, pathologies inhibiting or limiting its optimal functioning lead to troubles such as incontinence or, to mobility disorders associated with hemiplegia or paraplegia. Functional Electrical Stimulation (FES) techniques, which supplement or replace the nervous system by electrically stimulating nerves and/or muscles in order to obtain an artificial contraction, is one of the most promising solutions to the mentioned diseases. To use the FES system in a closed loop control could provide more optimal stimulation. Thus, an attractive solution could be the integration of sensory information, such as contact forces or warning signals of a full bladder, which help to optimize the efficiency of a stimulator [1]. Sensory information is carried by Action Potential (AP: potential difference between the outside and inside of the membrane of an axon) and is propagated by associated afferent fibres. Unfortunately, the large number of axons constituting the peripheral nerves makes the extraction of the studied signal particularly difficult. Moreover the sensory information recorded by an electrode gives a very low amplitude signal

compared with the amplitude of parasitic ones. For instance, on a monopolar recording, electromyogram (EMG) created by muscle activity, has an amplitude about three orders of magnitude higher than the electroneurogram (ENG), which is the recording of neural activities. Thus, to be able to exploit natural sensors, a neural recording system must allow the separation of different ENG recordings while rejecting parasitic external signals. In this paper, we begin with a brief discussion about the hexagonal cuff electrode presented in [2]. In a third part, the signal pre-processing amplifier developed according to the configuration of our electrode is detailed. Let us add that the band frequency of interesting signals is defined with the same model used to evaluate the external and internal sensibilities of our electrode. This model considers a $10\mu\text{m}$ diameter myelinated axon with a Ranvier nodes spacing about 1mm . Finally, the last part gives our perspectives and concluding remarks.

II. HEXAGONAL CUFF ELECTRODE

Cuff electrodes have been the most used in the last ten years [3]–[9]. They are relatively easy to implant and not invasive for the nerve. Their implantation is very stable and thus, allows chronic experiments. ENG can be recorded as the potential difference created on the electrodes by the charges associated to the AP propagating along the nerve fibers. Fig.1-a shows a typical tripolar cuff electrode.

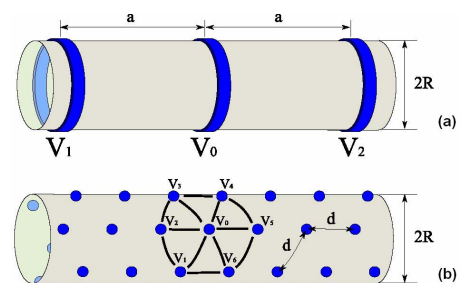

Figure 1. Tripolar (a) and hexagonal (b) cuff electrode models

With this kind of electrode, a classical method to reject parasitic signals consists in calculating the average of the potential differences between the central pole and each of the outer poles [10] – [12]:

$$V_{rec} = \frac{(V_0 - V_1) + (V_0 - V_2)}{2} = V_0 - \frac{V_1 + V_2}{2} \quad (1)$$

With the aim of obtaining more localized measures, we suggest to use a structure with a large number of poles in a hexagonal configuration (Fig. 1-b: 42 poles) [2]. The poles of this electrode are arranged in hexagonal patches. On each patch, we calculate the mean of the potential differences between the central pole and each of the peripheral poles:

$$V_{rec} = \frac{1}{6} \sum_{i=1}^6 (V_0 - V_i) = V_0 - \sum_{i=1}^6 \frac{V_i}{6} \quad (2)$$

Our theoretical results show that the hexagonal cuff electrode provides better sensitivity, better spatial selectivity and better signals rejection than a classical tripolar cuff electrode. An amplifier has been developed to perform the function of the equation (2), it is presented in the next part.

III. AVERAGING AMPLIFIER.

As explained in the previous part, the method to reject parasitical signals makes use of seven recording sites of the electrode for one recording channel. Thus, we designed a low-noise amplifier able to compute the difference between the recordings of the central pole of a hexagonal patch and the average of his six contiguous poles. This function is directly implanted at the transistor level, avoiding hence a classical structure with resistances and opamps, which are difficult to optimize in surface, noise or consumption. A preamplifier improves the signal to noise ratio of the ENG as well as rejecting parasitical signals. In a second stage, an instrumentation amplifier is added to increase the gain of the structure.

A. Preamplifier

The preamplifier is designed like a differential pair whose negative input transistor is split into six identical transistors (see figure 2). This idea allows us to design a structure using less than 20 transistors whereas the classical structure needs at least 8 opamps and resistances to obtain an equivalent functionality. Using the “small-signal” model of the transistor, it’s easy to show that:

$$V_{out1} - V_{out2} = \frac{g_{m_p}}{g_{m_n}} \sum_{i=1}^6 (V_0 - V_i) \quad (3)$$

Where g_{m_p} represents the transconductance of the P-MOS transistors connected to the inputs V_1 to V_6 while g_{m_n} is the transconductance of the diode connected NMOS transistors at the bottom of the schematic. These diode-connected transistors in parallel with the active load act as clamps in order to stabilise common mode output voltage. This solution

generates less noise than with a classic common mode feedback (CMFB) that requires several transistors.

The interesting signals have very low amplitudes (typically 1-5 μ V), so we paid attention to optimize the noise level in our designed structure. In order to evaluate the measurement frequency band, we considered the signals coming from two successive Ranvier nodes on a same axon. Given the typical spacing of these Ranvier nodes (1mm) and the speed of the AP propagation on a myelinated axon (lower or equal to 100m.s⁻¹), the delay between these signals is more than 10 μ s. In order to separate these pulses, we need a bandwidth of about 50kHz. Moreover, the speed of an AP can be below 100m.s⁻¹, thus low frequency signals resulting can be more drowned in the flicker noise than in the thermal noise of the structure.

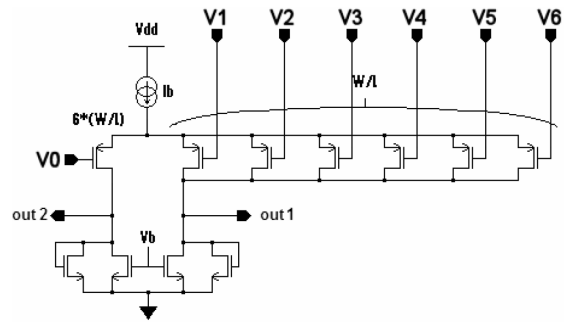

Figure 2. Seven input preamplifier schematic

Because using a noise reduction technique like chopper stabilization between the recording sites of the electrode and the inputs of the preamplifier is not possible, we had to choose the least noisy first stage. Typically, P-type transistors have less flicker noise than N-type transistors and using them for the input of an amplifier structure optimizes the slew rate and the unity-gain frequency [13]. Thus, the inputs of our preamplifier are P-type transistors in order to optimize the noise performances of the system (we obtained an input referred noise about 0,672 μ V_{rms} in the bandwidth of the preamplifier).

1) Simulations

Simulations are essential to evaluate the characteristics of the preamplifier. However, it is difficult to perform pertinent simulations with seven independent inputs. As a matter of fact, we need to validate that our device correctly computes equation (2), as well as rejecting parasitic components such as common mode. So, we have chosen to express the seven inputs signals of the preamplifier as seven combinations of seven fundamentals components $U_d, U_c, U_{d1}, U_{d2}, U_{d3}, U_{d4}$ and U_{d5} . U_d and U_c are respectively the differential (corresponding to Eq. 2) and common-mode input voltages (Cf. Eq. 4 and 5). U_{d1} to U_{d5} are the differential components characterizing the voltage distribution between V_1 to V_6 . The equations (6) and (7) define the transformation linking the U_{di} to the V_i signals.

$$U_d = \frac{1}{2} \left(V_0 - \frac{\sum_{i=1}^6 V_i}{6} \right) \quad (4) \quad U_c = \frac{1}{2} \left(V_0 + \frac{\sum_{i=1}^6 V_i}{6} \right) \quad (5)$$

$$U_m = U_c - U_d \quad (6)$$

$$\begin{pmatrix} U_m \\ U_{d1} \\ U_{d2} \\ U_{d3} \\ U_{d4} \\ U_{d5} \end{pmatrix} = \begin{pmatrix} 1 & 1 & 1 & 1 & 1 & 1 \\ 1 & 1 & 1 & -1 & -1 & -1 \\ 1 & -1 & 1 & 1 & -1 & -1 \\ 1 & -1 & -1 & 1 & 1 & -1 \\ 1 & -1 & -1 & -1 & 1 & 1 \\ 1 & 1 & -1 & -1 & -1 & 1 \end{pmatrix} \begin{pmatrix} V_1 \\ V_2 \\ V_3 \\ V_4 \\ V_5 \\ V_6 \end{pmatrix} \quad (7)$$

Using this transformation, we are able to simulate the transfer function between each U_{xx} component and the differential output voltage of the preamplifier. Figure 3 give the magnitude of these transfer functions in the frequency domain. In addition to the 40dB gain for U_d , the three main results of this simulation are:

- a 90dB rejection ratio for each of the U_{di} relatively to U_d
- a 200kHz bandwidth, larger than the 50kHz estimated requirement.
- more than 60 dB of common mode rejection ratio for the entire useful bandwidth.

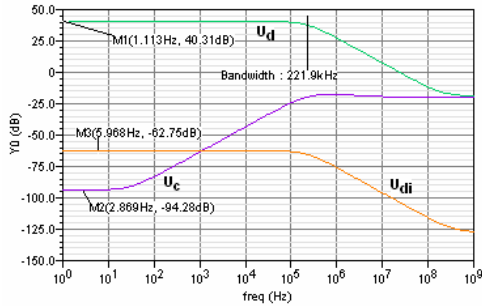

Figure 3. Frequency transfer function of the preamplifier

Figure 4 shows the corresponding static transfer functions. This static analysis shows that the differential gains $Y_0(U_{di})$ are approximately linear and negligible on the $-5mV$ to $5mV$ range around the polarization point. This range may appear narrow, however, since the recording sites of the electrode are close from each others, the difference of parasitic signals potentials U_{di} should be very small. i.e. in the range mentioned above. So, this band remains largely sufficient for the amplitude of the signals we want to measure.

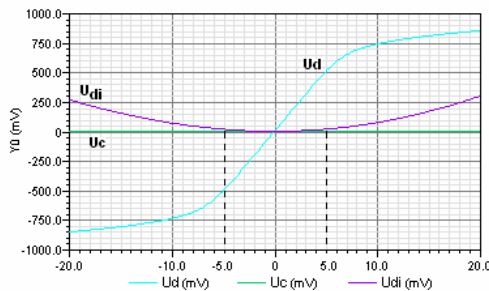

Figure 4. Static transfer function of the preamplifier

B. Instrumentation Amplifier

A 40dB gain would not be sufficient to allow ENG recordings with our electrode. Therefore, a two-stage instrumentation amplifier with variable gain was added to the preamplifier in order to increase and adjust the total gain of the structure according to the obtained records. The Signal to Noise Ratio optimization of this amplifier is less critical than the preamplifier one. Indeed, the preamplifier provides a signal that is strong enough compared to the noise generated at the input of the instrumentation amplifier. The variable gain of this instrumentation amplifier is digitally programmable with a set of resistances and switches. The first stage proposes the gains of 2, 10 or 100 while those of the second stage are 1, 10 or 100. Thus, the total gain of this instrumentation amplifier can be fixed on a range from 2 to 10.000 i.e. from 6dB to 80dB (the simulations give a 260kHz bandwidth, compatible with the preamplifier bandwidth).

C. Complete Circuit

A recording channel is associated to a hexagonal patch (one central recording site and its six neighbours), so the number of channels depends on the number of recording sites of the electrode. Since the boundary poles of the electrode could not be used as a central measurement point, for an n -poles electrode we need J channel with $J < n$. For example, with seven channels, the number of poles of the electrode is $19 \leq n \leq 49$. For the ASIC we have designed, our choice was to minimize the number of pads, so its input connections are made internally to fit a fully connected 19-pole electrode. Performances of this circuit have also been evaluated by Monte Carlo analysis and the results are reported in Table 1.

Active area (7 channels)	1.16mm ²
Supply Voltage	3.3V
DC Current (Preamp)	12μA
Voltage Gain (Preamp)	40dB
Voltage Gain (Inst amp)	6dB ≤ G ≤ 80dB
Voltage Gain (Full amp)	46dB ≤ G ≤ 120dB
Input ref. noise (Preamp)	0.672μV _{rms}
Input ref. noise (Full amp)	0.677μV _{rms}
Bandwidth (Full Amp)	≈ 220kHz

Table 1 Results simulated of the ASIC

These results achieve the required specifications since the total gain is $46dB \leq G \leq 120dB$, the bandwidth is larger than 50kHz and the input referred noise is below the μV_{rms} on this band. The circuit (figure 5) was designed in CMOS AMS 0.35μm technology.

IV. OUTLOOK

In the near future, we expect to carry on three experiments to evaluate our electrode efficiency. The first one will focus on the electrode sensitivity by measuring stimulated ENG with an electrode on a part of a nerve. The second one will aim to characterize the spatial selectivity.

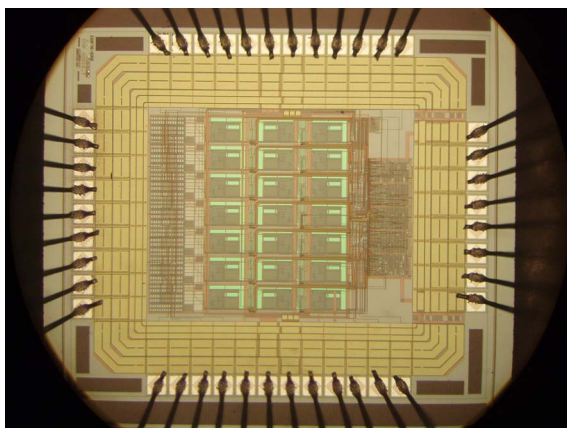

Figure 5. Microphotograph of the seven-channel prototype

During this experiment, we will try to isolate a nervous ramification, to stimulate some of the branches beyond this ramification and to get records, which distinguish the different stimulated branches. To conclude these tests, we will manipulate *in vivo* to evaluate the rejection of parasitic signals and we will pay special attention to rejection of muscular signals (EMG). Of course, the circuit presented in this paper will also be evaluated during experiments. A hexagonal cuff electrode has been manufactured (figure 6) to perform these three experiments and we should be able to bring our first results by summer 2008.

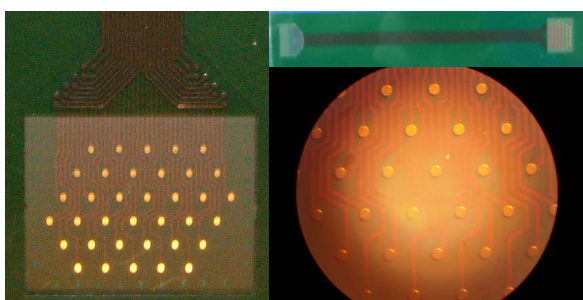

Figure 6. Photograph of the hexagonal cuff electrode

V. CONCLUSION

In this paper, the two first elements of an acquisition chain for nervous signals have been developed. The hexagonal cuff electrode offers characteristics such as a sensitivity and a parasitic signal rejection more interesting than those of a classical tripolar cuff electrode. A low-noise amplifier

developed by our team allows, at the transistor level, to average recorded signals nearby a recording pole and thus, to use a traditional rejection technique of external parasitic signals. The variable gain of this amplifier is digitally controlled and could be set dynamically. Experimental results about sensitivity, spatial selectivity and parasitic signals rejection will be provided as soon as the biological experiments are concluded.

REFERENCES

- [1] M. Djilas, C. Azevedo Coste, K. Yoshida, and G. Cathébras, "Interpretation of ENG signal for FES closed-loop control," in IFESS'06: 11th Annual Conference of the International Functional Electrical Stimulation Society, Miyagi-Zao, Japan, 12-15 Sep. 2006, pp. 85-87.
- [2] L. Gouyet, G. Cathébras, S. Bernard, D. Guiraud, Y. Bertrand, "A Cuff Electrode dedicated to ENG Recording with Multipolar Configuration for both Efficient Sensitivity and High Rejection of EMG Parasitic Signals", 9th Vienna International Workshop on Functional Electrical Stimulation, Krems, Austria, 2007.
- [3] Zoran M. Nikolić, Dejan B. Popović, Richard B. Stein and Zoltan Kenwell, "Instrumentation for ENG and EMG Recordings in FES Systems", IEEE Transactions on Biomedical Engineering, Vol 41 n°7, July 1994.
- [4] J. Winter, M. Rahal, J.Taylor, N. Donaldson, J.J Struijk, "Improved Spatial Filtering of ENG Signals Using a Multielectrode Nerve Cuff", Proceedings of the 5th Annual Conference of the International Functional Electrical Stimulation Society, 2000.
- [5] R. Rieger, J. Taylor, E. Comi, N. Donaldson, M. Russold, C.M.O. Mahony, J.A. McLaughlin, E. McAdams, A. Demosthenous and J.C. Jarvis, "Experimental determination of compound action potential direction and propagation velocity from multi-electrode nerve cuffs", Medical Engineering & Physics, 2004.
- [6] Lotte N.S. Andreasen and Johannes J. Struijk, "Artefact Reduction with Alternative Cuff Configurations", IEEE Transactions on Biomedical Engineering Vol 50 n°10, Oct 2003.
- [7] Lotte N.S. Andreasen and Johannes J.Struijk, "Skin Contact Forces Extracted From Human Nerve Signals - A Possible Feedback Signal for FES - Aided Control of Standing", IEEE Trans. On Biomed Eng, vol50 n°12, Dec 2003.
- [8] P.B. Yoo and D.M. Durand, "Selective Fascicular Recording of the Hypoglossal Nerve Using a Multi-Contact Nerve Cuff Electrode", Proceedings of the 25th Annual International Conference of the IEEE EMBS, Sept 17-21, 2003.
- [9] W. Tesfayesus, P. Yoo, M. Moffitt and D.M. Durand, "Blind Source Separation of Nerve Cuff Recordings", Proceedings of the 26th Annual International Conference of the IEEE EMBS, Sept 1-5, 2004.
- [10] Johanna Jan Struijk and Morten Thomsen, "Tripolar Nerve Cuff Recording : Stimulus Artefact, EMG and the Recorded Nerve Signal", IEEE-EMBC and CMBC Theme 5: Neuromuscular Systems/Biomechanics, 1995, pp 1105-1106.
- [11] Ch.Pflaum, R.R. Riso and G. Wiesspeiner, "Performance of Alternative Amplifier Configurations for Tripolar Nerve Cuff Recorded ENG", 18th Annual International Conference of the IEEE Engineering in Medicine and Biology Society, Amsterdam 1996.
- [12] Andreas Demosthenous, John Taylor, Iasonas F. Triantis, Robert Rieger and Nick Donaldson, "Design of an Adaptive Interface Reduction System for Nerve Cuff Electrode Recording", IEEE Transactions on Circuits and Systems ; Regular Papers, Vol 51 n°4, April 2004.
- [13] D.A. Johns and K. Martin, "Analog Integrated Circuit Design", John Wiley & Sons, Inc., 1997.