

## 3D Orientation Determination DEMO

Boris Alandry, Thierry Dusquesne, Laurent Latorre, Frédéric Maily, Pascal  
Nouet

► **To cite this version:**

Boris Alandry, Thierry Dusquesne, Laurent Latorre, Frédéric Maily, Pascal Nouet. 3D Orientation Determination DEMO. 2008. lirmm-00361236

**HAL Id: lirmm-00361236**

**<https://hal-lirmm.ccsd.cnrs.fr/lirmm-00361236>**

Submitted on 13 Feb 2009

**HAL** is a multi-disciplinary open access archive for the deposit and dissemination of scientific research documents, whether they are published or not. The documents may come from teaching and research institutions in France or abroad, or from public or private research centers.

L'archive ouverte pluridisciplinaire **HAL**, est destinée au dépôt et à la diffusion de documents scientifiques de niveau recherche, publiés ou non, émanant des établissements d'enseignement et de recherche français ou étrangers, des laboratoires publics ou privés.

**3D ORIENTATION DETERMINATION DEMO**

**Boris Alandry, Thierry Dusquesne, Laurent Latorre, Frederick Mailly  
and Pascal Nouet  
University of Montpellier 2**

**Montpellier, FRANCE**

**Abstract**

*The microelectronic department at LIRMM has developed, in the past few years, various types of MEMS sensors. The particularity of our group is to design MEMS that can be integrated either in a System on Chip (SoC) or in a System in Package (SiP) approaches.*

*Therefore, the purpose of this demonstration is to show the feasibility of a silicon attitude sensor using 2 MEMS magnetometers, 2 MEMS thermal accelerometers and the appropriate electronic architecture. This paper also presents the attitude calculation algorithm developed for this demonstration.*

**Table of Contents of the paper**

1. Introduction
2. Sensors overview
  - 2.1 Tilt sensors
  - 2.2 MEMS Magnetometers
3. Sensor combination
4. Electronic architecture
5. 3D orientation determination
6. Conclusion

**1. Introduction**

Interests in cheap 3D orientation determination is increasing as well as application to smaller appliances (i.e. mobile phones and smaller). First attempts to reach the market are currently happening, though not fully addressing high volume market needs (specialized sensors required) with a complete set of functionalities.

Our group has been working, in the past years, at the development of various types of MEMS sensors as well as the appropriate electronic architecture for each one. The particularity of our team is to design MEMS that can be integrated either in a System on Chip (SoC) or in a System in Package (SiP) approaches.

In this work, we present a complete system that can make the 3D orientation determination. This system is based on 4 MEMS sensors and the appropriate electronic architecture, both previously designed by the Microelectronic Department at LIRMM.

This paper will present the overall operation of the sensors first. Then, the combination of the sensors will give a brief sight of the overall system principle. The electronic architecture used in this demonstration will be, then, detailed. And finally, a method to calculate the attitude will be explained.

**2. Sensors overview**

Using a CMOS wafer with electronic parts on it, several techniques can be used to implement electro-mechanical sensors. FSBM appears as a very promising and cheap technique. Using this CMOS-FSBM process, LIRMM has developed 2 types of sensors: a thermal accelerometer and a magnetometer. In this study, we combine both to determine the attitude of the system. Therefore, details on these 2 sensors are given next.

**2.1. Tilt sensors**

A basic thermal accelerometer is shown in figure 1. It is made of three suspended resistors: the center beam is supplied by a current and acts as a heater while the two beams beside are temperature sensors. The detector resistors are arranged in a Wheatstone bridge and connected to an instrument amplifier. Under in-plane acceleration, the temperature profile created by the heater becomes asymmetric and the temperature gradient is converted into a resistance variation in the detectors. This sensor is sensitive enough to detect static acceleration such as the g-acceleration. Therefore this thermal accelerometer has tilt sensing capabilities. Such MEMS sensors have been previously introduced in [1] and also commercialized [2].

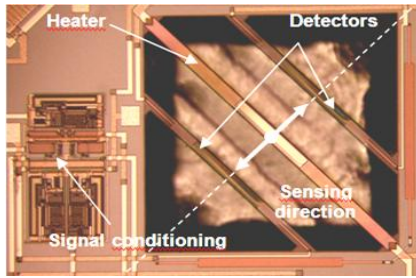

**Figure 1. Picture of a tilt sensor based on thermal convection.**

### 2.2. MEMS Magnetometers

The operating principle is based on the interaction of a calibrated current flowing into the structure with the external magnetic field that produces a Lorentz force.

This force causes the deformation of the cantilever, which is converted into an electrical signal by means of embedded polysilicon strain gauges. The use of this measurement principle in association with the FSBM technology is cost effective compared to the integration of magnetic cores in flux-gate devices, and allow better resolution than Hall effect devices [6]. The best sensitivity and resolution are obtained by driving the structure at resonance.

An electronic compass can be obtained combining 2 magnetometers with an angle of 90° between them. Figure 2 shows a compass made of 2 U-Shaped cantilever beams that measure X and Y components of the earth magnetic vector.

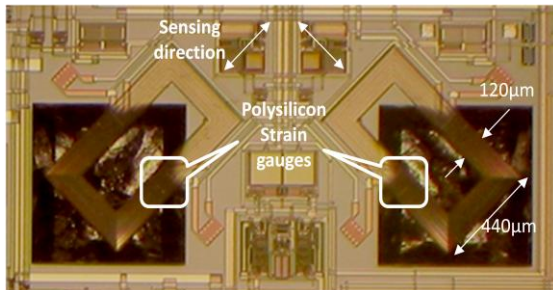
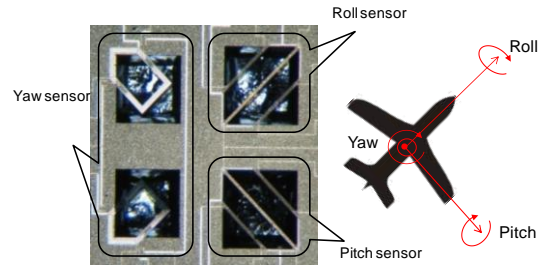

**Figure 2. The micro-machined compass made of two U-Shaped cantilevers.**

### 3. Sensor combination

As illustrated in figure 3, the combination of 2 thermal accelerometers and 2 magnetometers can give the attitude of the system.

In this system, pitch and roll information are given with respect to the earth gravity field while yaw is provided relatively to the north magnetic direction. Details on the 3D orientation calculation are presented in part 5.



**Figure 3. Attitude sensor made of the combination of 4 basic sensors.**

### 4. Electronic Architecture

In this demonstration, all the electronic will be made of discrete components. However, such components could be easily integrated in a CMOS technology to make the system all in a single chip (SoC) or package (SiP). The electronic architecture presented in figure 4 is derived from an electronic system previously depicted, fabricated and characterized in [8].

Basically, each sensor is connected to a low noise amplifier to prevent the SNR from early noise degradation. Because the 2 magnetometer strain gauges are mounted in a Wheatstone bridge configuration on chip, only one low noise amplifier is needed for both. A multiplexing strategy is applied for the tilt sensors in order to minimize the electronic area and consumption.

The electronic conditioning chain is the same for each sensor. Because all electronic blocs suffer from high 1/f noise, the signal coming from the various sensors are shifted in the frequency domain thanks to the microcontroller. In fact, the magnetometers are operated at the mechanical resonance (16 kHz) while for the gravitational sensors a Wheatstone bridge biasing modulation has been implemented. A band pass filter and an amplification chain are implemented in order to give a clear signal. The microcontroller also trigs the Track and Hold circuit for synchronous detection. Low pass filters and differential amplifiers are, then, used to give a continuous single ended output. Finally this signal is sent to the 10-bit microcontroller A/D converter to provide a digital output. At the end, an averaging strategy is applied to have a better resolution and the RS232 microcontroller module sends the data to a computer through a Bluetooth connection.

The whole system is based on a time multiplexing strategy and is controlled by an 8-bit RISC microcontroller from Microchip.

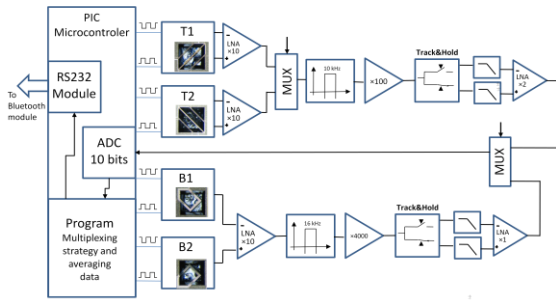

Figure 4. Electronic architecture

### 5. 3D orientation determination

In this demonstration, calculations to determine the attitude as well as the 3D representation are done with a Labview application. These calculations are based on Cardan's angle representation. Cardan's angles are, basically, pitch, roll and yaw angles used in aeronautic. Figure 5 shows Cardan's angle representation.

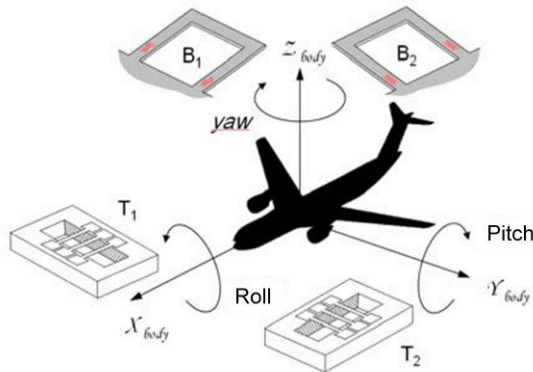

Figure 5. Cardan's angle representation

Using this representation, 6 possible transfer matrixes can be written. All these matrixes represent the same final orientation. With our type of sensors only 2 of them are useful and give solvable equations. These 2 matrixes are presented in figure 6 and figure 7 illustrates the 3 successive rotations for each matrix.

#### Cardan's matrixes

rotation order: Z->Y->X $\Phi(Z) \rightarrow \theta(Y) \rightarrow \psi(X)$		
$c(\theta)*c(\Phi)$	$c(\theta)*s(\Phi)$	$-s(\theta)$
$s(\psi)*s(\theta)*c(\Phi)-c(\psi)*s(\Phi)$	$s(\psi)*s(\theta)*s(\Phi)+c(\psi)*c(\Phi)$	$s(\psi)*c(\theta)$
$c(\psi)*s(\theta)*c(\Phi)+s(\psi)*s(\Phi)$	$c(\psi)*s(\theta)*s(\Phi)-s(\psi)*c(\Phi)$	$c(\psi)*c(\theta)$

rotation order: Z->X->Y $\Phi(Z) \rightarrow \theta(X) \rightarrow \psi(Y)$		
$c(\psi)*c(\Phi)-s(\psi)*s(\theta)*s(\Phi)$	$c(\psi)*s(\Phi)+s(\psi)*s(\theta)*c(\Phi)$	$-s(\psi)*c(\theta)$
$-c(\theta)*s(\Phi)$	$c(\theta)*c(\Phi)$	$s(\theta)$
$s(\psi)*c(\Phi)+c(\psi)*s(\theta)*s(\Phi)$	$s(\psi)*s(\Phi)-c(\psi)*s(\theta)*c(\Phi)$	$c(\psi)*c(\theta)$

Figure 6. Cardan's matrixes used for attitude determination

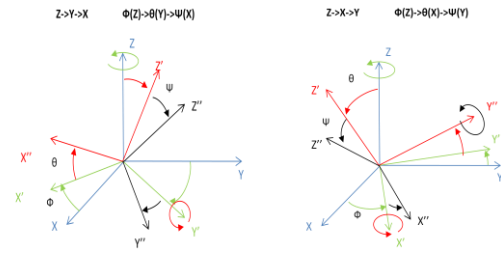

Figure 7. Cardan's successive rotations

In order to solve the system of equations, the reference coordinates system is aligned on earth magnetic and gravitational fields: x(ref) points the north direction while z(ref) is vertical.

Then, for each matrix, sensors equations can be written and a set of Cardan's angle can be determined.

For the first matrix (Z->Y->X), the readings of the tilt sensors T1 and T2, measuring the acceleration along the x(body) axis and y(body) axis respectively, are expressed as follow:

$$T1 = -g \times s(\theta) \tag{1}$$

$$T2 = g \times s(\psi)c(\theta) \tag{2}$$

The readings of the magnetometers B1 and B2, measuring the magnetic field along the x(body) axis and y(body) axis respectively, are expressed as follow:

$$B1 = Bh \times c(\theta)c(\Phi) - Bv \times s(\theta) \tag{3}$$

$$B2 = Bh \times [c(\psi)s(\theta)c(\Phi) - c(\theta)s(\Phi)] - Bv \times s(\psi)c(\theta) \tag{4}$$

The system is, then, solved and gives the 3 Cardan's angles.

$$\theta = -\arcsin\left(\frac{T1}{g}\right)$$

$$\psi = \arcsin\left(\frac{T2}{g \times c(\theta)}\right)$$

$$\Phi = -\arcsin\left(\frac{B1 + Bv \times s(\theta)}{Bh \times c(\theta)}\right)$$

The same calculations can be done for the second matrix and give another set of Cardan's angle.

Because the resolution on every angle is decreasing whenever the cosines or the sinuses of the angles are close to one, a weighted algorithm is applied on the two matrixes to get a better resolution. This technique avoids "Gimbal lock" effects on the rotation around the z-axis and increases, particularly, precision and resolution on every orientation.

### 6. Conclusion

This demonstration proves the feasibility of the system and introduces an original sensor combination for 3D orientation determination. The electronic architecture presented can be easily integrated and optimized for SoC or SiP prototyping. A simple algorithm has been explained and implemented in a Labview software for attitude determination. Further work will give more details on system performances, and comparison with other system could be done.

## References

- [1] N. Dumas, L. Latorre, P. Nouet, "Development of a Low-Cost Piezoresistive Compass on CMOS", Sensors and Actuators A, Vol. 130-131, August 2006, p. 302-311.
- [2] A.M. Leung, J. Jones, E. Czyzewska, J. Chen, B. Woods, "Micromachined accelerometer based on convection heat transfer", proc. IEEE MEMS'98, Heidelberg, Germany, 25-29 Jan. 1998, pp. 627-630.
- [3] A. Chaehoi, F. Mailly, L. Latorre, P. Nouet, "Experimental and finite-element study of convective accelerometer on CMOS", Sensors and Actuators A 132 (1) (2006), pp. 78-84.
- [4] A. Chaehoi, L. Latorre, S. Baglio, P. Nouet, "Piezoresistive CMOS Beams for inertial Sensing", proc. IEEE SENSORS 2003, Toronto, Canada ; Oct. 22-24, 2003, pp.142-143.
- [5] F. Mailly, A. Giani, A. Martinez, R. Bonnot, P. Temple-Boyer and A. Boyer, "Micromachined thermal accelerometer", Sensors & Actuators A 103 (3) (2003), pp. 359-363.
- [6] <http://www.memsic.com/memsic>
- [7] O. Leman, F. Mailly, L. Latorre, P. Nouet, "HDL modeling of convective accelerometers for system design and optimization", Sensors and Actuators A, In Press, available online
- [8] B. Alandry, N. Dumas, F. Mailly, L. Latorre, P. Nouet, "A CMOS Multi-sensor System for 3D Orientation Determination", proc. IEEE computer annual on VLSI (ISVLSI 2008), Montpellier, France, Apr. 7-9 2008.
- [9] H. Blanchard, F. De Montmollin, J. Hubin and R. S. Popovic, Highly sensitive Hall sensor in CMOS technology, Sensors and Actuators A: Physical, vol. 82, no. 1-3 (2000), pp. 144 - 148.

## About the Authors



Boris Alandry achieved an engineering diploma in 2007. He is currently a PhD student in the microelectronic department at University of Montpellier 2 and works in the MEMS Design and Test group.