

On the Use of Standard Digital ATE for the Analysis of RF Signals

Nicolas Pous, Florence Azais, Laurent Latorre, Jochen Rivoir

► **To cite this version:**

Nicolas Pous, Florence Azais, Laurent Latorre, Jochen Rivoir. On the Use of Standard Digital ATE for the Analysis of RF Signals. ETS: European Test Symposium, May 2010, Prague, Czech Republic. pp.43-48. lirmm-00492828

HAL Id: lirmm-00492828

<https://hal-lirmm.ccsd.cnrs.fr/lirmm-00492828>

Submitted on 17 Jun 2010

HAL is a multi-disciplinary open access archive for the deposit and dissemination of scientific research documents, whether they are published or not. The documents may come from teaching and research institutions in France or abroad, or from public or private research centers.

L'archive ouverte pluridisciplinaire **HAL**, est destinée au dépôt et à la diffusion de documents scientifiques de niveau recherche, publiés ou non, émanant des établissements d'enseignement et de recherche français ou étrangers, des laboratoires publics ou privés.

On the use of standard digital ATE for the analysis of RF signals

N. Pous
LIRMM & Verigy
34392 Montpellier, France

F. Azais, L. Latorre
LIRMM, CNRS / Uni. Montpellier 2
34392 Montpellier, France

J. Rivoir
Verigy Germany GmbH
71034 Boeblingen, Germany

Abstract— In this paper, we investigate the use of standard digital ATE for the analysis of FM-modulated RF signals. The key idea is to use the 1-bit digitizer of a digital test channel in order to convert the frequency information contained in a FM-modulated signal into a timing information contained in a digital bit stream; a post-processing algorithm based on the concept of zero-crossing detection is then employed to retrieve this information. Coherent under-sampling is exploited to extend the capabilities of test equipment with a limited sampling frequency for the analysis of high-frequency signals. The proposed approach is evaluated on two different case studies related to LTE and GSM communication standards. Both simulation and hardware experiments are presented to demonstrate the viability of the technique.

Keywords: test, digital ATE, analog/RF signals, zero-crossing detection, post-processing algorithm, coherent under-sampling

I. INTRODUCTION

More and more, with the development of wireless and multimedia applications, analog and RF functions become essential elements of electronic systems. In this context, it is clear that the test cost of such functions must be kept as low as possible to be competitive in the market. However in this particular case, the test is a time-consuming procedure that requires costly and dedicated test equipment.

In this work, our objective is to reduce the cost of the required test equipment. The fundamental idea is to complement standard low-cost test equipment with signal processing techniques to enable the analysis of analog/RF signals. More precisely, the idea is to use the comparator of a standard digital ATE channel as a 1-bit digitizer that converts the frequency and/or amplitude information contained in the analog/RF signal into a timing information contained in a digital signal; post-processing algorithms can then be developed to extract the analog/RF signal characteristics from the digital bit stream.

An essential motivation of this approach is that the current trend for actual circuits is to operate at lower supply voltages but with ever higher frequencies. This means that modern CMOS chips undergo a degraded voltage resolution whereas they benefit from an improved time resolution. Regarding test aspects, this trend can be translated into the fact that it is more and more difficult to perform accurate voltage measurements while it becomes easier to obtain precise timing measurements.

As a consequence, our idea is to take advantage of this trend by converting the analysis of analog/RF signals from the voltage domain to the time domain [1].

Moreover, another observation is that RF devices are often tested twice, at the wafer-level and again at the package-level. However implementing RF tests at wafer-level is extremely costly due to probing issues and the inability to perform multi-site testing. It is therefore of great interest to develop test solutions applicable on low-cost test equipment that (i) provide wafer-level test coverage and (ii) permit multi-site testing. Consequently, another important objective is the ability of performing some levels of RF testing using standard digital ATE channels together with the possibility of performing multi-site testing.

Referring to literature, our approach is quite innovative. Indeed, two main strategies have been investigated up-to now to diminish the test cost of analog/RF circuits. A first strategy is to include BIST features in the circuit in order to reduce the requirements of the external test equipment. During the past ten years, a significant research effort has been carried out in this direction for analog circuits [2,3] and more recently for RF circuits [4,5]. Another strategy is to reduce the test time, and a number of works have been realized to replace the classical specification-based tests by shorter alternative tests for both analog and RF circuits [6,7]. In this work, we adopt a slightly different approach that consists in reducing the requirements of the external test equipment but without inserting any test features within the circuit itself.

In this paper, we focus on the analysis of FM-modulated signals using the frequency reconstruction technique introduced in [8]. In order to extend the application range of the method, we introduce the use of coherent under-sampling and we evaluate the performances of the technique on two different case studies related to LTE and GSM communication standards.

The paper is organized as follows. Section II presents the basic principle of using standard digital ATE channels for frequency estimation together with the associated post-processing algorithm for frequency demodulation. Section III introduces the use of coherent under-sampling to enable the analysis of high-speed signals using test resources with limited operating frequency. Sections IV and V discuss the performances of the technique on the two different case studies. Finally section VI concludes the paper.

II. PRINCIPLE

A. Basic idea

Our objective is to investigate the possibility of using digital test resources, cheaper than the RF resources, to analyze analog/RF signals. Based on the concept of level-crossing detection, the idea is to complement a standard digital test channel with a signal processing algorithm so that it can operate as an analog/RF receiver. Note that many works can be found in the literature regarding the use of level-crossing in many different application domains such as image and speech processing, wireless communications... However only a limited number of works deals with the use of such a technique for analog/RF test issues. Zero-crossing is used in [9] to generate a digital signature associated with Lissajou-based test. Level-crossing is used in [10] to evaluate offset and amplitude of a triangular analog waveform using digital resources.

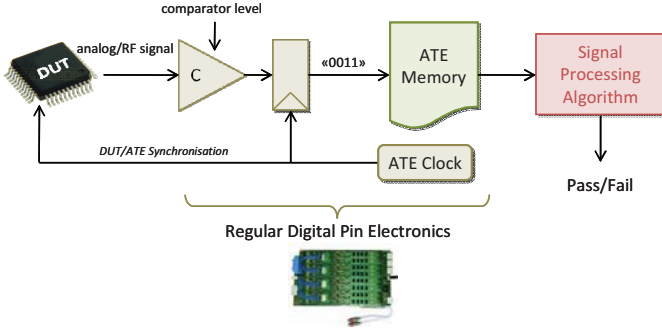

Figure 1. Primary idea

As illustrated in figure 1, the comparator of the digital test channel is used as a 1-bit digitizer and the resulting bit stream is stored in the ATE memory. Depending on the reference level of the comparator, the frequency and/or amplitude information contained in the analog/RF signal is converted into a timing information contained in the digital bit stream. It is then the role of the post-processing algorithm to retrieve the analog/RF signal characteristics. In this paper, we focus on frequency reconstruction, so we set the reference level of the comparator to zero. Similar solutions may be developed for amplitude reconstruction, using a comparator reference level different from zero.

B. Frequency determination

To illustrate the proposed approach, let us first consider an ideal analog sine-wave:

$$s(t) = A \cos(2\pi f \cdot t) \quad (1)$$

Assume that this sine-wave is sampled by a 1-bit comparator with a zero-reference level at a sampling rate f_{sample} . The resulting signal is a digital signal that switches from logical “0” to “1”. As illustrated in figure 2, a Time Stamp (TS) can be associated with each transition, which corresponds to a zero-crossing of the analog sine-wave. Then, for each pair of rising/falling transitions, the signal frequency can be computed with:

$$f = \frac{1}{2\Delta TS} \quad (2)$$

where ΔTS corresponds to the time delay between a pair of successive rising and falling transitions.

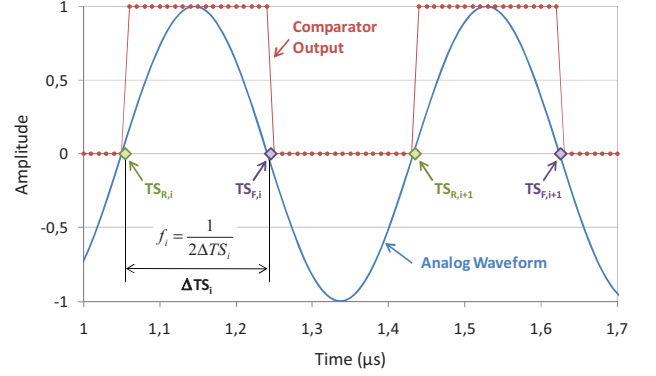

Figure 2. Frequency determination from zero-crossing

In the ideal case, level-crossings of the analog sine-wave result in unique transitions at the output of the comparator. Time Stamps can therefore be directly associated to the rising/falling transitions. However in practice, the analog signal is not a perfect one but a noisy signal. The resulting digital signal at the output comparator therefore exhibits multiple transitions at the vicinity of zero-crossings, as illustrated in figure 3. An algorithm is consequently required to filter these multiple transitions and associate a single Time Stamp to each zero-crossing.

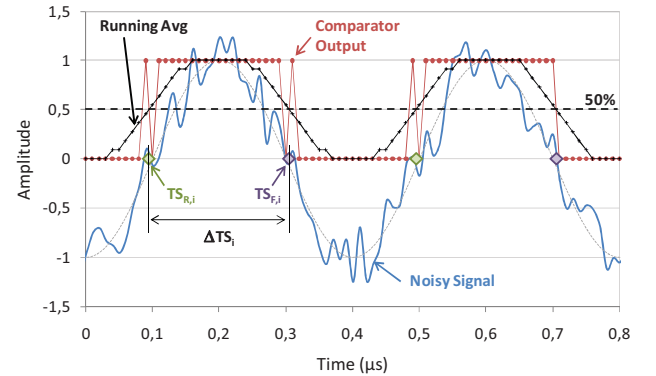

Figure 3. Frequency determination from running average

In this objective, a simple and robust algorithm that allows the precise estimation of Time Stamps associated with level-crossings for a noisy signal has been developed. As depicted in figure 3, the algorithm relies on a running average, i.e. counting the ratio between the numbers of “0” and “1” on a given number of samples N_{avg} . A Time Stamp TS_R is associated to a rising transition when this ratio reaches 50% with a positive slope; similarly, a Time Stamp TS_F is associated to a falling transition when the running average reaches 50% with a negative slope.

C. Frequency demodulation

Let us now consider the case of an FM-modulated signal expressed by:

$$S_{FM}(t) = A_c \cos(2\pi f_c \cdot t + \beta \sin(2\pi f_m \cdot t)) \quad (3)$$

where A_c and f_c are the amplitude and the frequency of the carrier signal, f_m is the frequency of the modulating signal (further called “the message”), and β is the modulation depth given by:

$$\beta = A_m \frac{f_d}{f_m} \quad (4)$$

and f_d corresponds to the maximum frequency deviation.

In order to demodulate this signal, we can use the zero-crossing Time Stamp determination defined in the previous section. More precisely, the principle consists in estimating the deviation of the signal frequency from the carrier frequency, for each period of the FM-modulated signal.

From a practical point of view, the procedure is as follows:

- For each $TS_{R,i} / TS_{F,i}$ pair, i.e. for each period of the carrier signal, we compute the time $t_{\max,i}$ at which the FM-modulated signal reaches a maximum:

$$t_{\max,i} = \frac{TS_{R,i} + TS_{F,i}}{2} \quad (5)$$

- For each pair of two consecutive maximums, we reconstruct the message with:

$$\hat{s}_m(t_i) = \frac{A_m}{\beta \cdot f_m} \left(\frac{1}{t_{\max,i+1} - t_{\max,i}} - f_c \right)$$

at $t_i = \frac{t_{\max,i} + t_{\max,i+1}}{2}$ (6)

Note that because the reconstruction is based on the processing of the sampled comparator output, the resulting reconstructed signal is a discrete signal both in time and amplitude. The timing discretization depends on the characteristics of the signal to be analyzed, i.e. the ratio between the modulating and carrier signal frequencies. The amplitude discretization not only depends on the signal characteristics but also on the sampling frequency. The quantization step can be expressed by deriving equation (6):

$$Q = \frac{A_m f_c^2}{2 f_m f_{\text{sample}} \beta} \quad (7)$$

From equation (7), it is clear that for a given signal, it is possible to reduce the quantization step and so to increase the number of quantization levels, by increasing the sampling frequency.

III. ANALYSIS OF HIGH-FREQUENCY SIGNALS

The accuracy of the proposed technique obviously depends on the accuracy on the frequency estimation, which is clearly related to the ATE sampling frequency f_{sample} . It actually depends on the ratio between the ATE sampling frequency and the frequency of the analog signal to be analyzed. So the higher

the sampling frequency is, the higher the number of captured samples per carrier period and the lower the frequency estimation error. As a consequence, this may limit the range of signals that can be analyzed since the sampling frequency is limited by the ATE capabilities. As an example, standard digital ATE can typically operate up to few GHz. Targeting accuracy better than 1% for frequency estimation, 200 samples per carrier period are required [8], and signals that can be analyzed are therefore limited to few tens of MHz.

In order to extend the application range of the method, the idea is to use a coherent under-sampling strategy. Indeed, under-sampling is a commonly-used strategy to address the capture of high-frequency repetitive signals below the Nyquist rate. It basically consists in taking only few samples within a signal period and repeating this operation several times while changing the sampling phase. The resulting multiple samples can then be reordered to obtain a satisfactory sampling of the original signal. Besides, coherent sampling is a technique that guarantee that the maximum amount of information about a particular waveform exists in the sample set (i.e. there are no duplicate samples). Implementing coherent sampling therefore permits to obtain a complete, periodic waveform representation in the sample set with faster acquisition time and less computation than with non-coherent sampling. Consequently, we introduce in this section the implementation of a coherent under-sampling approach with the ATE to address the capture of high-frequency analog waveforms.

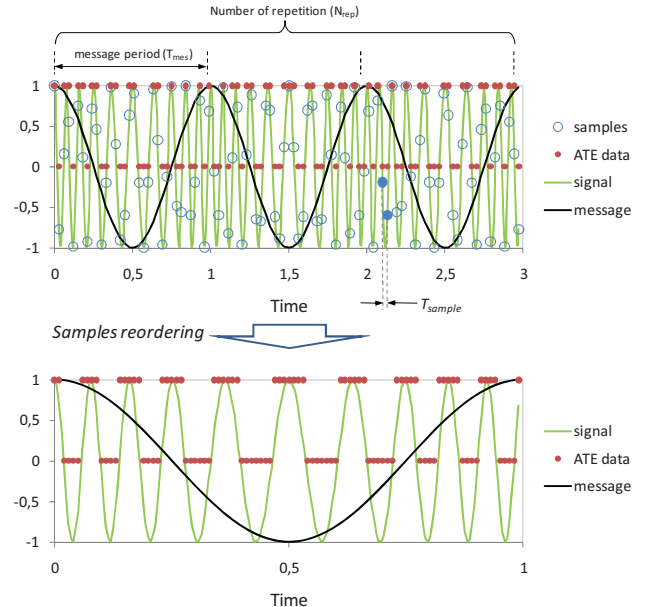

Figure 4. Coherent under-sampling

Figure 4 illustrates the principle of coherent under-sampling on a simple case of FM-modulated signal with $f_c=100\text{kHz}$ and $f_m=10\text{kHz}$. To ensure coherency, the sampling frequency f_{sample} , the message frequency f_m , the number of samples N and the number of repetitions of the message signal M must fulfill the following relationship:

$$\frac{N}{f_{\text{sample}}} = \frac{M}{f_m} \quad (10)$$

where N and M are whole positive integer values. Moreover, N and M must be chosen as co-prime integers to guarantee that samples will differ from one message signal period to another.

Referring to the example of figure 4, the coherency constraints can be satisfied with the sampling period set to $T_{sample}=3\mu s$ and the number of repetitions set to $M=3$. After reordering, this setup permits to collect 100 uniformly time-distributed samples on one message period, whereas the direct sampling of the signal without repetition produces only 33 samples on one message period.

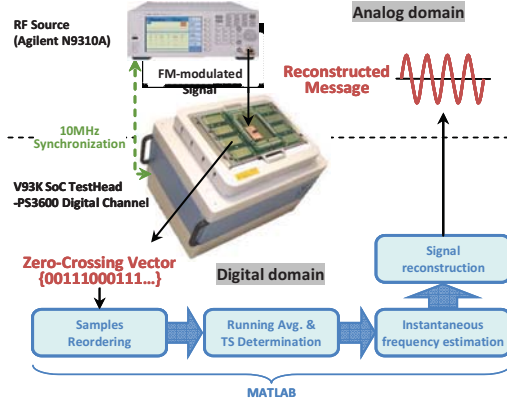

Figure 5. FM-demodulation setup using digital ATE

Figure 5 shows the proposed test setup for FM-demodulation using a digital ATE and a coherent under-sampling approach. The signal to be analyzed is generated with an RF source (Agilent N9310A) connected to a PS3600 digital channel of the Verigy 93K ATE. In order to implement coherent sampling, synchronization is required between the signal and sample clock frequencies. The 10MHz output of the tester is therefore used to synchronize the RF source. The post-processing algorithm that includes samples reordering, running average computation and time stamps determination, instantaneous frequency estimation, and finally signal reconstruction is implemented in MATLAB®.

IV. “LTE-BANDWIDTH” CASE STUDY

To validate the proposed approach, we first consider a case study based on the LTE standard. The purpose is not to handle the complete communication standard, but to use the frequencies involved in such applications as a typical RF signal. Consequently referring to one mode of the LTE standard, we consider a FM-modulated signal with a carrier frequency of 2.5GHz, a modulation frequency of 40MHz and a modulation depth $\beta=3$. Moreover to evaluate the performances of the technique, we want to analyze the spectrum of the reconstructed message. In order to have an acceptable resolution after the FFT, the signal to be analyzed is made of 32 message periods, which corresponds to 2000 carrier periods; the message period T_m considered in the experiments is therefore 800ns. Note that the reconstruction algorithm results in a discrete analog signal with non-uniform time distribution according to equation (6). This non-uniformity should be considered for the analysis of the signal in the frequency domain. Indeed, applying a classical Discrete Fourier

Transform (DFT) algorithm on the reconstructed signal with non-uniform samples results in a spectrum that presents both leakage and harmonics. It is therefore necessary to align data on a uniform time scale [11] or to use an Interpolated-DFT algorithm to eliminate these effects and obtain the correct spectrum of the signal.

TABLE I. UNDER-SAMPLING PARAMETERS FOR “LTE” CASE STUDY

Final resolution after reordering	Number of repetitions M	ATE sampling period T_{sample}	Number of samples N
10 ps	601	6.010 ns	80,000
1 ps	6007	6.007 ns	800,000

First experiments have been performed in simulation. Two different time resolutions of 10ps and 1ps have been considered, which corresponds to about 40 and 400 samples per period carrier respectively. Taking into account that the lowest value of our ATE sampling period is 2.5ns, coherent under-sampling must be used to achieve such resolutions. The under-sampling parameters that satisfy the tester constraints and the coherent requirements are given in Table I for both targeted resolutions. Also, note that a clock jitter, modeled as a Gaussian random time-shift of the sampling event with $3\sigma=1ps$, has been included in the simulation in order to consider realistic practical conditions.

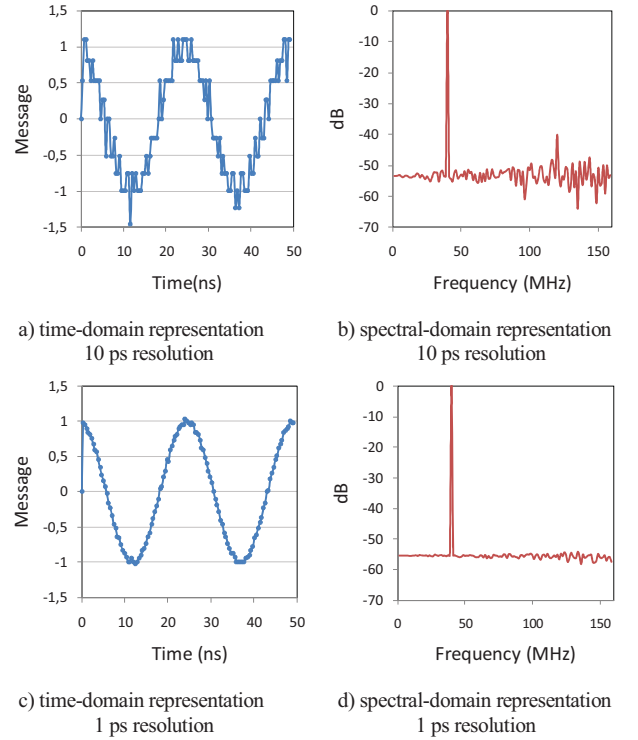

Figure 6. Simulation results for the “LTE” case study

Results are summarized in figure 6 that gives both the time-domain and the spectral-domain representation of the reconstructed signals for the two resolutions of 10ps and 1ps. It clearly appears that in both cases, the post-processing algorithm permits to retrieve the message. As expected, the quality of the reconstructed signal increases with time

resolution, with a significant reduction of the quantization in the message amplitude when improving the time resolution from 10ps to 1ps.

Hardware measurements have been performed to further support these results. However due to the limited capabilities of our RF source, hardware measurements are performed with a downscaling of 1,000 with respect to simulation, i.e. the RF source is set to output an FM-modulated signal with 2.5MHz carrier frequency, 40kHz modulation frequency and a modulation depth of 3rad. To maintain the same number of samples as in the simulation experiments, the downscaling of 1,000 is also applied on the ATE sampling frequency, which results in a time resolution of 10ns and 1ns, for 80,000 and 800,000 captured samples respectively. Note that even if the direct acquisition of the samples would be possible for the 10ns resolution, coherent under-sampling is implemented for both targeted resolutions. Results are summarized in figure 7. A good agreement is observed between these experimental results and simulation results.

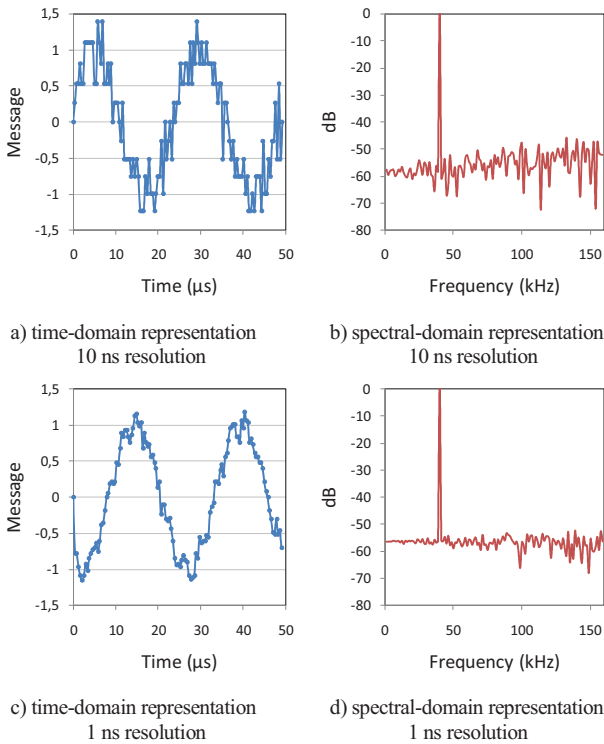

Figure 7. Hardware validations for the “LTE” case study

V. “GSM” CASE STUDY

The second case study addresses the demodulation of a FM signal with parameters close to those found in the GSM telecommunication standard. Note that although a GMSK modulation scheme is implemented in GSM in order to control the signal spectral spreading, our study only focuses on the determination of carried symbols based on frequency demodulation.

The typical GSM signal considered here is based on a sinusoidal carrier of frequency $f_c=914\text{MHz}$ and a frequency

deviation of $f_d=\pm 67.7\text{kHz}$ corresponding to “0” and “1” symbols. Note that this deviation is extremely small with regard to the carrier frequency. In order to discriminate symbols, the precision in the measurement of the carrier instantaneous frequency must therefore be higher than 0.015%. In other words, the targeted time resolution after sampling and reordering should be as low as 0.08ps, which corresponds to about 13,500 samples collected into one single carrier period. Obviously, this is a very exigent case and it is interesting to evaluate the performance of the proposed technique under such demanding conditions.

Additionally it is worth noting that the symbol rate in GSM is about 270kHz; each symbol is therefore emitted during 3.7 μs , which corresponds to 3,385 carrier periods. Considering a time resolution of 0.08ps, the amount of data to collect within one single symbol then reaches 46Mbits, which is way beyond ATE capabilities. In this study, first attempts to demodulate a GSM signal is addressed by setting the total amount of captured data to 16Mbits, which corresponds to our ATE memory capability. As a result, the capture window is lower than the duration of one symbol, and it is assumed that there is no change in the carrier frequency during the capture process. Different time resolutions are investigated, i.e. 0.1ps, 0.05ps and 0.01ps, which corresponds to 10,000, 20,000 and 100,000 samples per carrier period respectively. Obviously, coherent under-sampling is implemented to achieve such resolutions. The ATE sampling period and the number of repetitions are adjusted according to the targeted time resolution (ATE sampling frequency is adjusted around its minimum value of 2.5ns). Table II summarizes the under-sampling parameters used both in simulation and for experimental validation.

TABLE II. UNDER-SAMPLING PARAMETERS FOR “GSM” CASE STUDY

<i>Final resolution after reordering</i>	<i>Number of repetitions</i>	<i>ATE sampling period</i>	<i>Number of samples / carrier period</i>	<i>Number of carrier periods</i>
0.1 ps	~ 22,800	~ 2.5 ns	10,000	1,600
0.05 ps	~ 45,700	~ 2.5 ns	20,000	800
0.01 ps	~ 228,500	~ 2.5 ns	100,000	160

Simulations have been carried out using two signal frequencies of $f_{c0}=913.9323\text{MHz}$ and $f_{c1}=914.0677\text{MHz}$ corresponding to “0” and “1” symbols respectively. Again, a Gaussian jitter with $3\sigma=1\text{ps}$ is considered for the sampling clock. The post-processing algorithm is applied on the captured samples to estimate, for each carrier period, the instantaneous frequency.

Results are summarized in figure 8, which gives the distribution of the instantaneous frequency calculated for each carrier period, for the three different time resolutions. It can be observed that the instantaneous frequency exhibits a Gaussian distribution well-centered on the expected frequencies for “0” and “1” symbols, for the three different cases. On the other hand, the standard deviation strongly depends on the time resolution: the finer the time resolution, the lower the standard deviation. In particular, the standard deviation reduces down to about 30kHz when using a 0.01ps resolution, which permits to discriminate symbols based on a single period measurement.

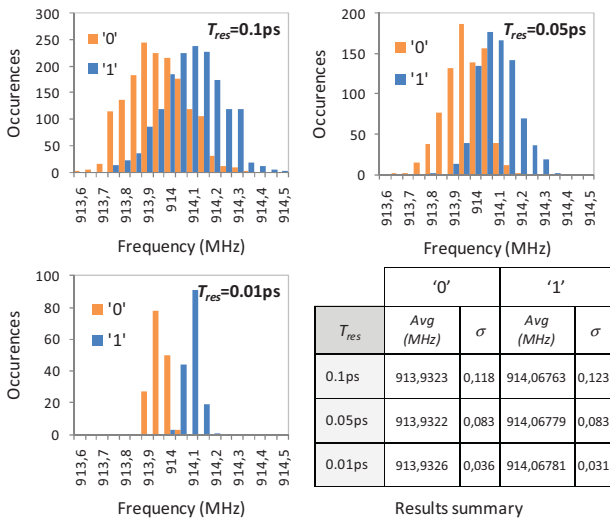

Figure 8. Simulation results for the “GSM” case study

More generally, these results demonstrate the potentialities of the proposed approach to handle GSM-type signals. However it should be highlighted that the use of a very fine time resolution may not be the more efficient option in terms of acquisition time and subsequent post-processing. An interesting alternative may be to use a degraded time resolution together with an averaging approach. For instance with a 0.1ps resolution, it is possible to achieve a standard deviation comparable to the one obtained with 0.01ps resolution by averaging the estimated frequency over 4 carrier periods only.

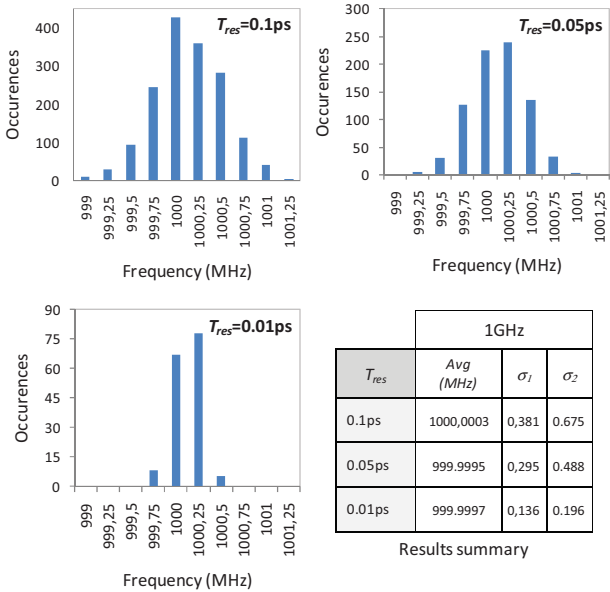

Figure 9. Hardware validations for the “GSM” case study

Finally, hardware measurements have been performed to further validate these results. A simple 1GHz signal send to two distinct tester channels on the same PS3600 board and the post-processing algorithm has been applied to estimate the frequency at each signal period. Results are summarized in figure 9. Frequency distribution is again very well-centered on

the expected 1GHz frequency and the standard deviation reduces when the time resolution improves. However compared to simulation results, the standard deviation is about three times higher on channel 1 and more than 5 times higher on channel 2. This difference may come from the jitter on the capture event that can have slightly different values from one channel to another.

VI. CONCLUSION

In this paper, we have validated a technique that permits to reconstruct the message contained in a FM-modulated signal using standard digital ATE channels, converting the analog/RF signal into a bit stream whose transition time information represents the analog/RF signal characteristics. We have also established that coherent under-sampling can efficiently complement the technique to process signals at frequencies much higher than the ATE acquisition rate. Validations have been performed through simulations and experimental measurements, and the viability of the technique has been illustrated on two case studies with very different characteristics.

ACKNOWLEDGMENTS

The authors would like to acknowledge B. Pradarelli, R. Lorival, P. Coscat and L. Ollivier for technical support during hardware validation. Hardware experiments have been performed using the equipment of the CNFM Test Resource Center in Montpellier sponsored by Verigy® and Region Languedoc-Roussillon.

REFERENCES

- [1] Rivoir, J; (Agilent Tech.), “Analog to digital signal conversion method and apparatus”, Patent No. US 6,462,693 B1, Oct. 2002
- [2] Khaled, S.; Kaminska, B.; Courtois, B.; Lubaszewski, M.; “Frequency-based BIST for analog circuit testing”, Proc. IEEE VLSI Test Symp., pp. 54-59, 1995.
- [3] Hao-Chiao Hong; Jiun-Lang Huang; Kwang-Ting Cheng; Cheng-Wen Wu; “On-chip analog response extraction with 1-bit Σ - Δ modulators”, Proc. IEEE Asian Test Symp., pp. 49-54, 2002.
- [4] Negreiros, M.; Carro, L.; Susin, A.A., “Low cost analogue testing of RF signal paths”, Proc. Design, Automation and Test in Europe Conference and Exhibition, pp. 292-297, 2004.
- [5] Staszewski, R.B.; Bashir, I.; Eliezer, O.; “RF Built-in Self Test of a Wireless Transmitter”, IEEE Transactions on Circuits and Systems II: Express Briefs, Volume 54, Issue 2, pp. 186-190, Feb. 2007.
- [6] Variyam, P.N.; Chatterjee, A.; “Enhancing test effectiveness for analog circuits using synthesized measurements”, Proc. IEEE VLSI Test Symp., pp. 132-137, 1998.
- [7] Haider, A.; Chatterjee, A.; “Low-cost alternate EVM test for wireless receiver systems”, Proc. IEEE VLSI Test Symp., pp. 255-260, 2005.
- [8] Pous, N.; Azais, F.; Latorre, L.; Nouet, P.; Rivoir, J., “Exploiting zero-crossing for the analysis of FM modulated analog/RF signals using digital ATE”, Proc. IEEE Asian Test Symp., pp. 261-266, 2009.
- [9] Brosa, A.M.; Figueras, J.; “Digital signature proposal for mixed-signal circuits”, Proc. IEEE Int’l Test Conf., pp. 1041-1050, 2000.
- [10] Su, C.C.; Chang, C.S.; Huang, H.W.; Tu, D.S.; Lee, C.L.; Lin, J.C.H.; “Dynamic analog testing via ATE digital test channels”, Proc. IEEE Asian Test Symp., pp. 308-312, 2004.
- [11] Rivoir, J.; (Verigy), “Converting non-equidistant signals into equidistant signals”, Patent Application No. WO 2008/022653 A1, Feb. 28, 2008