



HAL
open science

AM-Demodulation of Analog/RF Signals Using Digital Tester Channels

Nicolas Pous, Florence Azaïs, Laurent Latorre, Jochen Rivoir

► **To cite this version:**

Nicolas Pous, Florence Azaïs, Laurent Latorre, Jochen Rivoir. AM-Demodulation of Analog/RF Signals Using Digital Tester Channels. IMS3TW 2010 - 16th IEEE International Mixed-Signals, Sensors and Systems Test Workshop, Jun 2010, La Grande Motte, France. 10.1109/IMS3TW.2010.5503013 . lirmm-00494546

HAL Id: lirmm-00494546

<https://hal-lirmm.ccsd.cnrs.fr/lirmm-00494546v1>

Submitted on 23 Jun 2010

HAL is a multi-disciplinary open access archive for the deposit and dissemination of scientific research documents, whether they are published or not. The documents may come from teaching and research institutions in France or abroad, or from public or private research centers.

L'archive ouverte pluridisciplinaire **HAL**, est destinée au dépôt et à la diffusion de documents scientifiques de niveau recherche, publiés ou non, émanant des établissements d'enseignement et de recherche français ou étrangers, des laboratoires publics ou privés.

AM-demodulation of analog/RF signals using digital tester channels

N. Pous
LIRMM & Verigy
Montpellier, France

F. Azais, L. Latorre
LIRMM, CNRS/U. Montpellier 2
161 rue Ada,
34392 Montpellier, France

Jochen Rivoir
Verigy Germany GmbH
Herrenberger Str. 130,
71034 Boeblingen, Germany

Abstract — This paper investigates a signal acquisition protocol based on level-crossings that permits the demodulation of AM analog/RF signals using only standard digital ATE. The fundamental concept is to capture the signal through the 1-bit comparator available in digital tester channels and to process the resulting bit stream to retrieve the analog/RF signal characteristics. The proposed solution is evaluated through both simulation and hardware experiments.

Keywords: test, digital ATE, analog/RF circuits, level-crossing, coherent under-sampling, AM demodulation

I. INTRODUCTION

The production test of analog and RF circuits traditionally involves dedicated instruments to perform the acquisition or generation of analog signals. This instrumentation is found in ATE platforms in the form of specific boards that are typically characterized by their sampling frequency and resolution (number of bits). Compared to traditional digital resources, these equipments are extremely expensive.

The requirements regarding instrumentation performance are obvious in the context of a final test, where the quality of the product has definitively to be guaranteed. Wafer-level test is less demanding, in particular if we consider that it must only be good enough to avoid throwing away too many packages. In this context, simpler tests with less capable equipment may be developed.

Our idea is to use standard digital ATE channels to perform some level of RF testing without increasing the cost of the ATE. More precisely, we investigate the opportunity of using the 1-bit digitizer available on low-cost digital channels boards to analyze analog/RF signals. This approach is motivated by the fact that devices operate at ever lower supply voltage while speed is ever increasing. Our idea is to exploit this trend and to convert the analysis of analog/RF signals from the voltage domain to the time domain [1]. In addition, it is worth noting that because digital channels are widely available on most ATE platforms, multi-site testing can be actually considered with almost no additional cost.

More specifically, our work investigates the reconstruction of analog/RF modulated signals to address wafer-level testing of telecommunication devices. Standard modulation schemes

commonly involve phase/frequency or amplitude-shift keying, or a combination of both. In this paper, we focus on amplitude-modulated signals.

The paper is organized as follows. Section II summarizes our previous work on the reconstruction of phase/frequency-modulated signals based on zero-crossings. Using a similar approach, section III introduces the AM-demodulation concepts and examines the effects of acquisition parameters such as the sampling frequency or the crossing-level in the reconstruction properties. Simulation and experimental results are then discussed in sections IV and V respectively. Finally section VI concludes the paper.

II. PREVIOUS WORK

Our strategy to reduce the cost of testing analog/RF functions is to develop test solutions applicable with standard low-cost test equipment in order to provide wafer-level test coverage; the final product will be then tested at package-level using traditional solutions. This approach slightly differs from the main strategies presented in the literature, which consist in either inserting BIST features within the circuit in order to reduce the requirements of the test equipment [2-5], or applying shorter alternative tests instead of classical specification-based tests [6-7]. Our strategy consists in complementing standard low-cost test equipment with signal processing techniques to enable the analysis of analog/RF signals. In particular, the approach is based on the concept of level-crossing detection, which has been widely used in many different application domains such as image and speech processing, wireless communications... but more sparingly in the context of analog/RF testing [8-9].

As illustrated in figure 1, the proposed approach relies on the use of the comparator of a standard digital test channel as a 1-bit digitizer in order to convert the analog/RF signal into a bit stream whose transition time information represents the analog/RF signal characteristics. Signal processing algorithms can then be developed to extract the analog/RF signal characteristics. This approach has been introduced in [10] and a dedicated algorithm based on zero-crossing detection has been developed for the analysis of FM-modulated signals. Furthermore, coherent under-sampling has been exploited in

[11] to extend the capabilities of test equipment with limited sampling frequency for the analysis of high-frequency signals. In this section, we briefly recall the procedure for FM-demodulation of high-frequency signals.

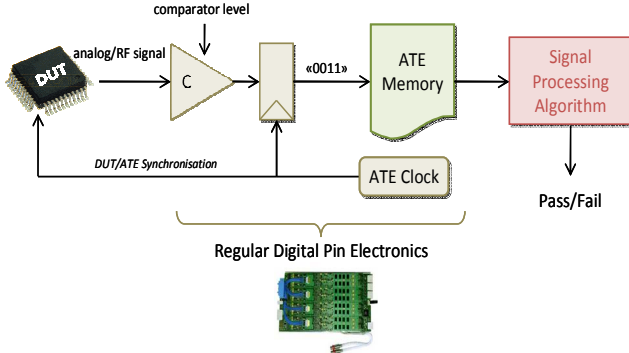

Figure 1. Primary idea

The procedure is based on the precise determination of the signal zero-crossing times. To illustrate the approach, let us consider an analog sine-wave sampled by a 1-bit comparator with a zero reference level. The resulting signal at the comparator output is a digital signal that switches from logical “0” to logical “1” and Time Stamps (TS) can be associated to the rising/falling transitions. Then for each pair of rising/falling transitions, the signal frequency can be computed as $f=1/2\Delta TS$, where ΔTS corresponds to the time delay between a pair of successive rising and falling transitions.

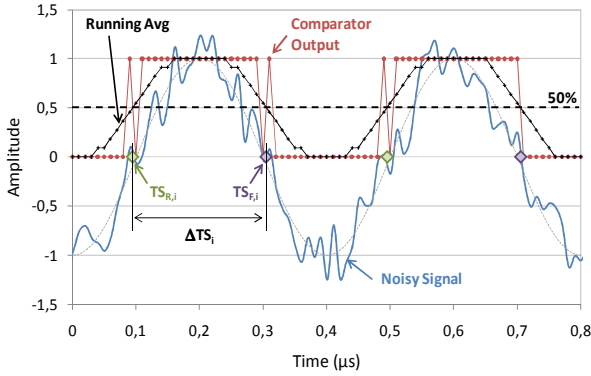

Figure 2. Time Stamp determination from running average

In the ideal case, zero-crossings of the analog sine-wave result in unique transitions at the output of the comparator. However in practice, the analog signal is not a perfect but a noisy signal. As a consequence, multiple transitions at the vicinity of zero-crossings may be present in the digital signal delivered by the comparator (see figure 2). To filter these multiple transitions and associate a single Time Stamp to each zero-crossing, we have proposed a simple and robust algorithm based on a running average, i.e. counting the ratio between the numbers of “0” and “1” on a given number of samples. A Time Stamp TS is then associated to a transition when the ratio reaches 50%.

The FM-demodulation principle is directly based on the zero-crossing TS determination. More precisely, the principle consists in estimating the deviation of the signal frequency from the carrier frequency, for each period of the FM-modulated signal. Practically, the FM-modulated signal is sampled by the ATE comparator with zero reference level. To handle high-frequency signals, coherent under-sampling can be implemented. In this case, the signal is repeated an integer number of times (M), while an integer number of samples (N) is captured at a sampling rate f_{sample} . To ensure coherency, the sampling frequency f_{sample} , the message frequency f_m , the number of samples N and the number of repetitions of the message signal M must fulfill the following relationship:

$$\frac{N}{f_{sample}} = \frac{M}{f_m} \quad (1)$$

where N and M are whole positive integer values. Moreover, N and M must be chosen as co-prime integers to guarantee that samples will differ from one message signal period to another.

The first step of the post-processing algorithm is then to perform sample reordering on the digital bit stream stored in the ATE memory, also called the zero-crossing vector. The second step corresponds to running average computation and associated TS determination. Finally for each pair of successive rising and falling transitions ($TS_{R,i} / TS_{F,i}$), i.e. for each period of the carrier signal, the deviation of the signal frequency from the carrier frequency f_c is estimated by:

$$\Delta f(t_i) = \frac{1}{2(TS_{R,i} - TS_{F,i})} - f_c \quad (2)$$

$$\text{at time } t_i = \frac{TS_{R,i} + TS_{F,i}}{2}$$

This reconstructed signal is a discrete signal that corresponds to the modulating signal and that can be further analyzed using FFT for instance.

III. AM-DEMULATION

In this section, we introduce the principle of AM-demodulation based on level-crossing. The concept is similar to FM-demodulation but this time, the idea is to convert the amplitude information contained in an analog/RF signal into timing information contained in the digital bit stream. The comparator should therefore be set with a reference level different than zero.

A. Basics of amplitude estimation

First to illustrate the approach, we consider an ideal analog sine-wave expressed by:

$$s(t) = A * \sin(2\pi * f * t + \varphi) \quad (3)$$

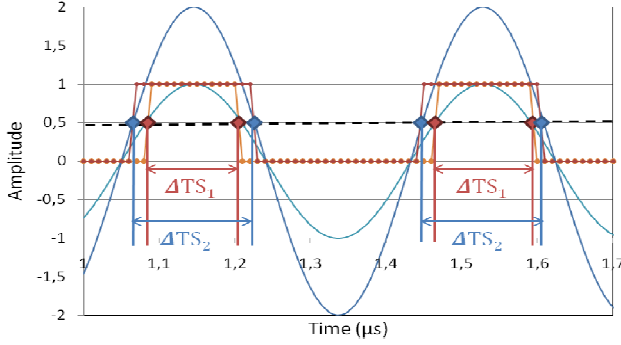

Figure 3. Time Stamps associated to level-crossings for two ideal sine-waves of different amplitude

Assume that this analog sine-wave is sampled by a 1-bit comparator with a reference level C different than zero, at a sampling rate f_{sample} . The resulting bit stream can be processed to determine the Time Stamps $TS_{R/F}$ associated with the level-crossings of the signal.

Figure 3 illustrates the Time Stamps associated to level-crossings for two ideal sine-waves with different amplitude. It can be seen that the larger the sine-wave amplitude, the larger the difference ΔTS between a rising and consecutive falling transitions. This difference is actually directly related to the sine-wave amplitude with:

$$A_i = \frac{C}{\cos(\pi * f * \Delta TS_i)} \quad (4)$$

The assumption here that the signal frequency is known is not a strong requirement. Indeed, either the signal frequency is effectively known from the application, either it can be easily determined from two successive rising (or falling) transitions of the zero-crossing vector with:

$$f = \frac{1}{TS_{R/F,i+1} - TS_{R/F,i}} \quad (5)$$

Finally, note that in practice we will not have ideal sine-waves but noisy ones, so the running average algorithm will be used to have a correct estimation of the Time Stamps. Besides, coherent under sampling can be implemented to handle high-frequency signals.

B. Amplitude demodulation

Let us now consider the case of an amplitude-modulated signal defined by:

$$S_{AM}(t) = A(t) * \sin(2\pi * f * t) \quad (6)$$

In the specific case of a modulation with a sinusoidal signal, we have:

$$S_{AM}(t) = [\alpha(1 + \beta \cos(2\pi * f_m * t + \phi))] * \sin(2\pi * f_c * t) \quad (7)$$

with $\alpha = A_0 + A_c$ and $\beta = A_m / A_0$

where A_c and f_c are the amplitude and the frequency of the carrier signal, A_m and f_m are the amplitude and the frequency of

the modulating signal (further called “the message”), and A_0 is the offset voltage.

Here again the demodulation principle is based on the Time Stamp determination previously introduced. The idea is to estimate, for each period of the AM-signal, the amplitude of the modulated signal with eq (4). This amplitude directly corresponds to the amplitude of the reconstructed signal at time $t_i = (TS_{R,i} + TS_{F,i}) / 2$.

Figure 4 summarizes the proposed flow, which is very similar to the FM-demodulation case. The only differences are that the comparator should be set with a reference level different than zero, and eq (4) is used to compute the message amplitude from the Time Stamps.

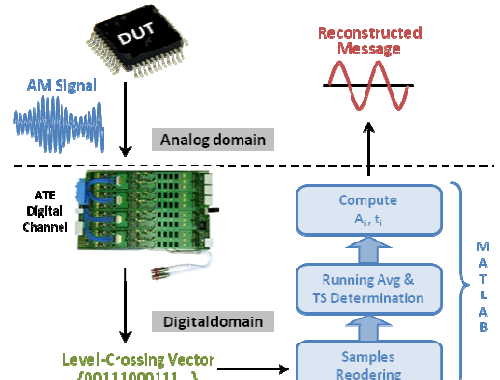

Figure 4. AM-demodulation using ATE digital channel

IV. SIMULATION RESULTS

In this section, we investigate the effectiveness of the proposed algorithm through simulations. First, we analyze on a simple sine-wave the impact of the comparator threshold, number of acquired samples, and noise level, on the accuracy of the estimated amplitude. Then, we evaluate the performances of the AM-demodulation algorithm on a practical case study.

A. Amplitude estimation results

A number of MATLAB simulations have been performed considering a simple sine-wave signal of amplitude 1V and varying the noise level and the ATE sampling rate, for different values of the comparator reference level. For each simulation, we have estimated the amplitude over 10,000 periods of the signal, and we have computed the mean value and the standard deviation of the estimated amplitude. Results are summarized in figure 5, which gives the estimation error on the mean value together with measurement standard deviation under different conditions.

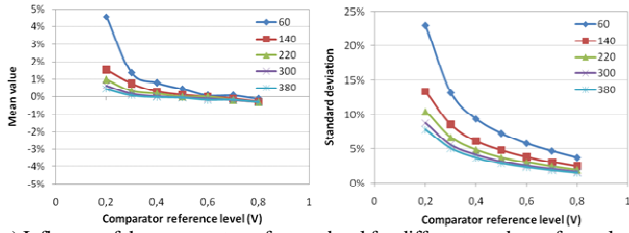

a) Influence of the comparator reference level for different numbers of samples per signal period with a noise level of 5%

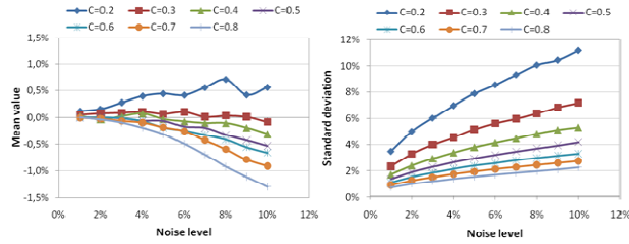

b) Influence of the noise level for different values of the comparator reference level with 380 samples per signal period

Figure 5. Amplitude estimation error: mean value and standard deviation

Figure 5.a analyzes the influence of the comparator reference level for different numbers of samples per period in case of a sine-wave with 5% noise. A first comment is that better results are obtained when the comparator reference level is higher than 50% of the signal amplitude. Indeed for all values of the comparator reference level above 0.5V, the estimation error on the mean amplitude value remains below $\pm 1\%$; the estimation error increases with a systematic overestimation of the signal amplitude for lower values of the comparator reference level.

These results show that the amplitude can be estimated with a good accuracy whatever the comparator reference level, provided that enough samples are collected. Indeed, the estimation error on the amplitude mean value can be as high as 5% when using only 60 samples per period with a comparator reference level at 0.2V whereas this error remains below $\pm 1\%$ when 220 samples or more are collected whatever the comparator reference level. So a first recommendation to achieve good accuracy in amplitude estimation is to collect at least 200 samples per signal period. Nevertheless, measurements show a relative dispersion, with a standard deviation that goes from 10% down to 1% when the comparator reference level increases from 20% to 80% of the signal amplitude range, for 220 or more samples per period. So a second recommendation is to set the comparator reference level as high as possible with respect to the signal amplitude.

To further validate these results, we have performed experiments varying the level of noise injected in the signal from 1% up to 10%. As illustrated by figure 5.b for 380 samples collected per period, the noise level has an impact on the accuracy of prediction but even in presence of 10% noise in the signal, the estimation error on the mean

amplitude value remains in the range of $\pm 1\%$ whatever the comparator reference level. However dispersion on the measurements can be relatively important depending on the comparator reference level.

B. AM-demodulation results

To validate the AM-demodulation algorithm, we consider an AM-signal with a carrier frequency $f_c = 2.5\text{GHz}$ and a modulating frequency $f_m = 40\text{MHz}$ as a practical case study. The ratio between the maximum amplitude and minimum amplitude of the AM-signal is set to 3 with $A_\theta = 2\text{V}$ and $A_c = A_m = 1\text{V}$. Moreover, to be able to perform an FFT with an acceptable resolution on the reconstructed message, the signal to be analyzed is made of 32 message periods.

The AM-demodulation algorithm has been simulated for different values of the comparator reference level from 20% up to 80% of the minimum AM-signal amplitude, which corresponds to about 6% up to 26% of the maximum AM-signal amplitude. A clock-jitter, modeled as a Gaussian random time-shift of the sampling event with $\sigma = 1\text{ps}$, has been included in all simulations in order to consider realistic practical conditions.

Figure 6 gives the time-domain and the spectral-domain representations of the reconstructed signal, for two different time resolutions of 2.5ps and 1ps. It clearly appears that in both cases the post-processing algorithm permits to retrieve the message, and this, whatever the value of the comparator reference level. However as expected, the quality of the reconstructed signal is better for higher comparator level and time resolution.

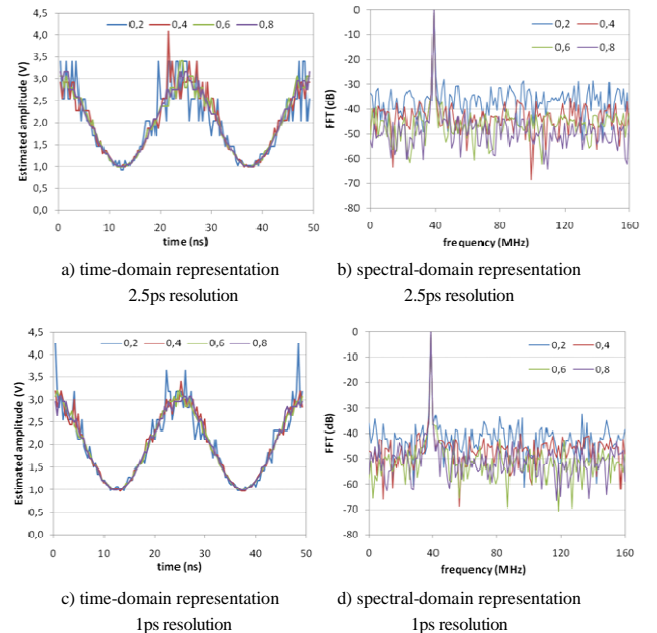

Figure 6. Reconstructed signal for different time resolutions and different comparator reference levels

These first results demonstrate the capability of the technique to perform AM-demodulation. In order to further validate the technique, we have performed similar simulations including noise in the signal. Results are summarized in Table I, which reports the SNR values measured over 160MHz bandwidth on the reconstructed signal with 2.5ps and 1ps resolution, for different levels of noise injected in the AM-signal.

TABLE I. SNR VALUES MEASURED ON THE RECONSTRUCTED SIGNAL FOR DIFFERENT TIME RESOLUTIONS AND DIFFERENT LEVELS OF NOISE INJECTED IN THE AM-SIGNAL

		Comparator reference level			
		0.2	0.4	0.6	0.8
2.5ps time resolution	without noise	15dB	22dB	25dB	24dB
	SNR _{IN} =34dB	15dB	21dB	25dB	23dB
	SNR _{IN} =26dB	12dB	20dB	23dB	20dB
	SNR _{IN} =20dB	9dB	17dB	21dB	18dB
1ps time resolution	without noise	20dB	26dB	29dB	31dB
	SNR _{IN} =34dB	19dB	26dB	29dB	30dB
	SNR _{IN} =26dB	17dB	24dB	26dB	30dB
	SNR _{IN} =20dB	14dB	22dB	25dB	28dB

Results are in agreement with the preliminary study performed in the previous section. We observe a smooth degradation of the quality of the reconstructed signal when the level of noise increases, with an SNR value that reduces by about 5dB when the noise level increases from 0 to 10%. In addition, we clearly observe the improvement in the quality of the reconstructed signal when increasing the number of acquired samples and for higher values of the comparator reference level. Note that even a comparator reference level at 80% of the minimum AM-signal amplitude is not the most favorable case for accurate amplitude estimation, as it only corresponds to 26% of the maximum AM-signal amplitude. To further improve the accuracy, a potential solution may consist in combining multiple level-crossings.

V. HARDWARE EXPERIMENTS

Hardware measurements have been performed to support these results. Hardware measurements have been carried out using the test setup depicted in figure 7. The signal to be analyzed is generated by an RF source (Agilent N9310A) directly connected to a PS3600 digital channel of the Verigy 93K ATE. The 10MHz output signal of the RF source is used to synchronize the tester. Indeed, the sample reordering process associated with the under-sampling method requires a very precise synchronization between the analog signal to be captured and the ATE sampling clock.

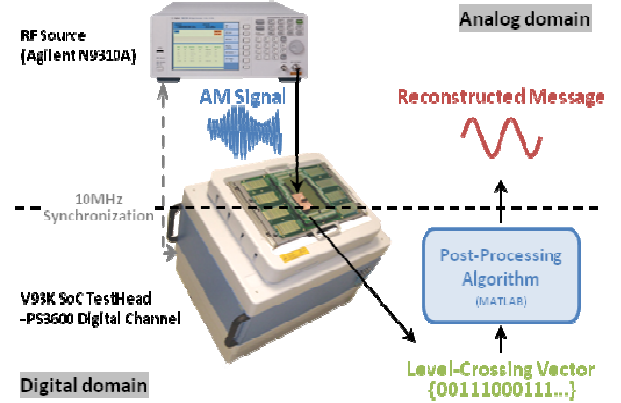

Figure 7. AM-demodulation setup using digital ATE

We have considered the case study used in simulation to experimentally validate the AM-demodulation algorithm. However due to the limited capabilities of our RF source, hardware measurements are performed with a downscaling of 1,000 with respect to simulation, i.e. the RF source is set to output an AM-modulated signal with 2.5MHz carrier frequency, 40kHz modulation frequency and a modulation depth of 50%. To maintain the same number of samples as in the simulation experiments, the downscaling of 1,000 is also applied on the ATE sampling frequency, which results in a time resolution of 2.5ns and 1ns for 320,000 and 800,000 captured samples respectively. Note that the 2.5ns resolution can be achieved with a direct acquisition of the samples without reordering, but that coherent under-sampling and reordering is mandatory to achieve the 1ns resolution (ATE sampling frequency limited to 400MHz).

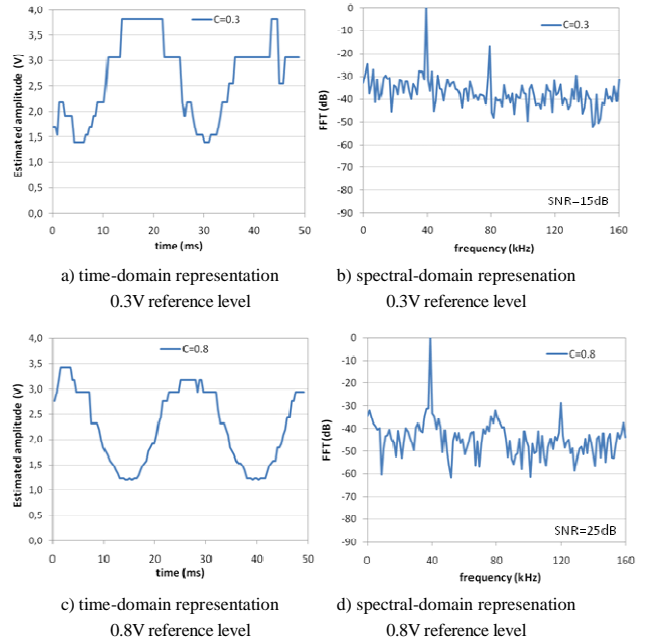

Figure 8. Reconstructed signal for 2.5ns resolution and different values of the comparator reference level

Figure 8 gives the time-domain and the spectral-domain representations of the reconstructed signal for the 2.5ns resolution and two different values of comparator reference level set at 30% and 80% of the minimum AM-signal amplitude. Analyzing these results, it can be clearly observed that a better reconstruction of the message is achieved when increasing the comparator reference level. The quantization in the time-domain reconstructed signal is visibly reduced, the overestimation is lessened; and the SNR improves from 15dB up to 25dB. These values are in rather good agreement with simulation results.

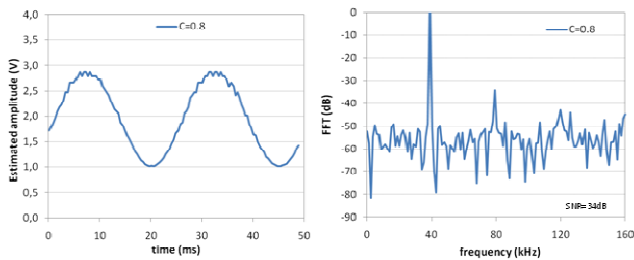

Figure 9. Reconstructed signal for 1ns resolution and 0.8V comparator reference level

Figure 9 gives the time-domain and the spectral-domain representations of the reconstructed signal when using a 1ns resolution and a comparator reference level at 80% of the minimum amplitude. A good accuracy on the message reconstruction is achieved with a clean time-domain representation, an estimated signal well-centered between 1V and 3V minimum and maximum amplitudes, and an SNR that improves up to 34dB. Here again, these results are in accordance with simulation results.

More generally, these hardware experiments validate the proposed technique since they actually show that the message of an AM-signal can be reconstructed from the sampling of the signal through a digital tester channel. The accuracy of the reconstruction depends on both the time resolution and the comparator reference level. Considering the practical case study investigated in this paper, an SNR around 15dB is obtained when using only 160 samples per carrier period and around 21dB when using 400 samples per carrier period, for a comparator reference level at 30% of the AM-signal minimum amplitude. When the comparator reference level is set to 80% of the AM-signal minimum amplitude, the SNR improves up to 25dB when using 160 samples per carrier period and 34dB when using 400 samples per carrier period.

VI. CONCLUSION

This paper investigates a signal acquisition protocol based on level-crossing and dedicated post-processing reconstruction algorithm in order to develop low-cost test strategies for

analog/RF devices. The idea is to use the comparator available in ATE digital channels to perform the signal capture and conversion in the digital domain; the resulting bit stream is then processed to retrieve the analog/RF signal characteristics. In this paper, we have focused on the analysis of amplitude-modulated signal. First, we have investigated the impact of acquisition parameters on the reconstruction quality, leading to basic rules for the determination of the sampling frequency and the comparator threshold. Then, we have investigated through simulation the performance of the AM-demodulation algorithm on a case study. Finally, hardware experiments have been presented demonstrating the viability of the proposed technique.

ACKNOWLEDGMENTS

The authors would like to acknowledge Dr. Beatrice Pradarelli for technical support during hardware validation. Hardware experiments have been performed using the equipment of the CNFM Test Resource Center in Montpellier sponsored by Verigy® and Région Languedoc Roussillon.

REFERENCES

- [1] Rivoir, J.; (Verigy), "Analog to digital signal conversion method and apparatus", Patent No. US 6,462,693 B1, Oct. 2002
- [2] Khaled, S.; Kaminska, B.; Courtois, B.; Lubaszewski, M., "Frequency-based BIST for analog circuit testing", Proc. IEEE VLSI Test Symposium, pp. 54-59, 1995.
- [3] Hao-Chiao Hong; Jiun-Lang Huang; Kwang-Ting Cheng; Cheng-Wen Wu, "On-chip analog response extraction with 1-bit Σ - Δ modulators", Proc. IEEE Asian Test Symposium, pp. 49-54, 2002.
- [4] Negreiros, M.; Carro, L.; Susin, A.A., "Low cost analogue testing of RF signal paths", Proc. Design, Automation and Test in Europe Conference and Exhibition, pp. 292-297, 2004.
- [5] Staszewski, R.B.; Bashir, I.; Eliezer, O., "RF Built-in Self Test of a Wireless Transmitter", IEEE Transactions on Circuits and Systems II: Express Briefs, Volume 54, Issue 2, pp. 186-190, Feb. 2007.
- [6] Variyam, P.N.; Chatterjee, A., "Enhancing test effectiveness for analog circuits using synthesized measurements", Proc. IEEE VLSI Test Symposium, pp. 132-137, 1998.
- [7] Haider, A.; Chatterjee, A., "Low-cost alternate EVM test for wireless receiver systems", Proc. IEEE VLSI Test Symposium, pp. 255-260, 2005.
- [8] Brosa, A.M.; Figueras, J., "Digital signature proposal for mixed-signal circuits", Proc. IEEE International Test Conference, pp. 1041-1050, 2000.
- [9] Su, C.C.; Chang, C.S.; Huang, H.W.; Tu, D.S.; Lee, C.L.; Lin, J.C.H., "Dynamic analog testing via ATE digital test channels", Proc. IEEE Asian Test Symposium, pp. 308-312, 2004.
- [10] Pous, N.; Azaïs, F.; Latorre, L.; Nouet, P.; Rivoir, J., "Exploiting zero-crossing for the analysis of FM modulated analog/RF signals using digital ATE", Proc. IEEE Asian Test Symposium, pp.308-321, 2009.
- [11] Pous, N.; Azaïs, F.; Latorre, L.; Nouet, P.; Rivoir, J., "Experiments on the analysis of phase/frequency-modulated RF signals using digital tester channels", Proc. IEEE Latin-American Test Workshop, 2010.