



HAL
open science

A Reconfigurable Robot for Cable-Driven Parallel Robotic and Industrial Scenario Proofing

Jean-Baptiste Izard, Marc Gouttefarde, Micaël Michelin, Olivier Tempier,
Cédric Baradat

► **To cite this version:**

Jean-Baptiste Izard, Marc Gouttefarde, Micaël Michelin, Olivier Tempier, Cédric Baradat. A Reconfigurable Robot for Cable-Driven Parallel Robotic and Industrial Scenario Proofing. 1st International Conference on Cable-Driven Parallel Robots (2012), 2012, Stuttgart, Germany. pp.135-148, 10.1007/978-3-642-31988-4_9 . lirmm-00737650

HAL Id: lirmm-00737650

<https://hal-lirmm.ccsd.cnrs.fr/lirmm-00737650>

Submitted on 31 May 2021

HAL is a multi-disciplinary open access archive for the deposit and dissemination of scientific research documents, whether they are published or not. The documents may come from teaching and research institutions in France or abroad, or from public or private research centers.

L'archive ouverte pluridisciplinaire **HAL**, est destinée au dépôt et à la diffusion de documents scientifiques de niveau recherche, publiés ou non, émanant des établissements d'enseignement et de recherche français ou étrangers, des laboratoires publics ou privés.

A Reconfigurable Robot for Cable-Driven Parallel Robotic Research and Industrial Scenario Proofing

Jean-Baptiste Izard, Marc Gouttefarde, Micaël Michelin,
Olivier Tempier and Cedric Baradat

Abstract Picturing the interest of research institutions and industrial actors, the list of research and demonstration parallel cable-driven robot prototypes is growing by the day. LIRMM and Tecnalía have decided to put knowledge in common in order to develop novel concepts for cable-driven parallel robotics and demonstrate its capabilities in industrial tasks. We have developed together a reconfigurable cable robot for this purpose. The robot main characteristics, e.g. footprint, mobile platform geometry and drawing point layout can be modified at will, making it particularly suitable for studying in good conditions new configurations or novel control laws, as well as any scenario suggested by our partners. The present paper first provides an overview of the robot. Afterwards, a more specific view on the different components and the capabilities of reconfiguration are presented, as well as examples of layouts meant for various research and industrial projects.

1 Introduction: Previous Art

The different scientific developments that occurred in the past years in cable-driven parallel robotics have brought today the introduction of these concepts in factories, civil work sites, buildings and warehouses just a step away. Scientific developments are still underway, e.g. on the control of cable-driven parallel robots in crane-like configurations, a promising branch of parallel cable-driven robotics in terms of applications. One of the major limitations to transposing cable-driven robots to industry is however them being accepted for carrying out real world applications. Parallel

J-B Izard (✉) · M. Michelin · C. Baradat
Tecnalía France MIBI, 672 rue du Mas de Verchant, 34000 Montpellier, France
e-mail: jeanbaptiste.izard@tecnalia.com

M. Gouttefarde · O. Tempier
LIRMM, UMR 5506, CC 477, 161 rue Ada, 34095 Montpellier Cedex 5, France

cable-driven robot reconfigurability is probably a key to this issue especially when various tasks are assigned to the robot.

Since the development of the FALCON [1] and of the Robocrane [2], which were among the first proofs of operability with good performances for fast manipulations, numerous contributors have developed various options for operation of cable-driven parallel robots. Applications requiring movements in a large workspace for crane-like applications [2], emergency deployable robots [3, 4], giant telescopes [5], aerial cameras [6, 7], service robotics [4] and positioning and measuring systems in wind tunnels [8] may be cited. Several others parallel cable-driven robots for research have been developed, e.g. the SEGESTA [9] and IPAnema [10].

Each of the aforementioned applications has specific requirements, which lead to different parallel cable robot configurations. At LIRMM and Tecnalía, we have considered the recent constraints in academic research that urged to develop new technical concepts, such as specific control laws and cable models, and on the other hand the pressing need by potential end users of cable-driven robots to have at their disposal a parallel cable-driven robot prototype. The main goal is to test different scenarios and different robot configurations: different operational spaces (e.g. planar, spatial, with different numbers of degrees of freedom), various platform configurations (flat, single point, spatial), different cable layouts (crane-type suspended configurations, fully constrained designs) and different constraints on the design due to the objectives of the scenario at hand. As a result, we have carried out research on choosing the optimal configuration for a specific scenario, but we also developed a parallel cable-driven prototype that is easily reconfigurable. This prototype is called ReelAx. The purpose of this paper is to describe the main components of ReelAx and the various configurations that have been tested so far.

2 Specifications

Geometry specifications are based on the positions of the cable output points, which are the points at which the cable are drawn out from the base frame, and the attachment points, where the cables are attached to the mobile platform. The first geometrical requirement of ReelAx is reconfigurability. It should be possible to easily modify the positions of the output points and of the attachment points, and also the cable connection between them.. In addition, the different elements of the cable robots should be easily transported. The maximum number of cables is 8.

The size of the maximum workspace of the robot is limited by the total length of each cable. This length has been set at 6.6 m to be able to cross the diagonal of a 4 m edge cube, and thus in order to be able to sweep through a workspace larger than that of most serial robot. The height of the output points shall be up to 3 m above the ground.

The platform maximum load is 25 kg. It has been decided that the cables should be able to resist the full weight of the platform each with some margin, that lead to

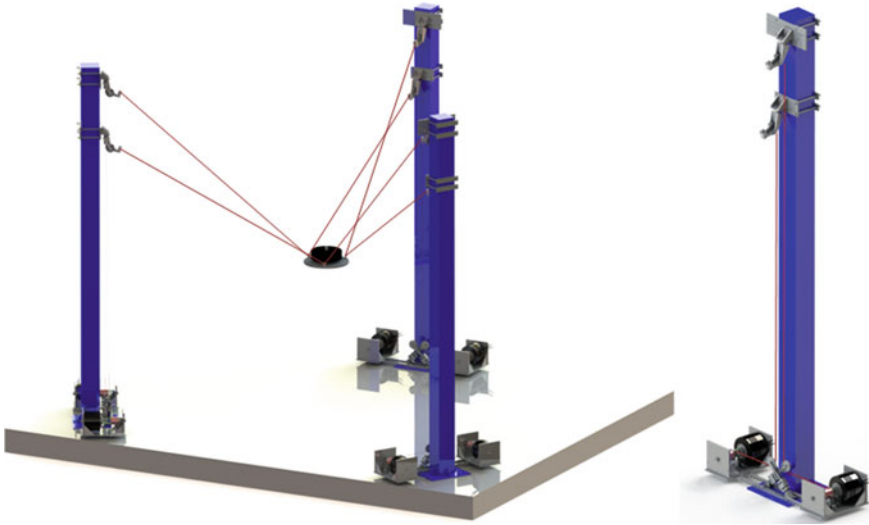

Fig. 1 *Left* general view of the suspended ReelAx6 configuration with three posts and six cables. *Right* view of a single post

a maximum tensile force in the cable of 300 N. Typical mobile platform velocities imply cable length modification speeds up to 1.5 m/s.

The cable routing between the drum and the output point should include a force sensor in a way that cable tension can be measured. In addition, in order to avoid any perturbation on the geometrical model of the robot, the routing path of the cable should be of the same length whatever the length of cable reeled in.

3 ReelAx Design Description

3.1 General Layout

A base frame must be built in order to assemble the various components of the cable-driven robot. This structure has to withstand the forces applied by the components which are due to the loading of the cables, whose sum is equal to the weight of the platform and the dynamic forces it undergoes. In the case of the robot ReelAx, the structure is composed of up to 4 steel posts that are 3 m high, with 2 cables being attached to each post (Fig. 1).

With these 4 posts, the reconfigurability is typically carried out in three steps:

- The first one is the selection of the number and of the positions of the posts around the workspace. It sets the horizontal dimensions of the maximal workspace and the number of cables.

- Second, the position of each post output points are configured, moving a block which redirects the cable. Indeed, each output point block can be clamped anywhere on the post, and the user is free to set the horizontal spacing between the output points (within a limited range).
- Third, the platform is designed to have the dimensions that are required by the application at hand, and built on purpose with standard interfaces for cables.

The winches are placed at the bottom of the posts. They cannot be moved. The cable goes out of the winch at the same position whatever the angular position of the drum and is then directed towards a vertical pulley, which deflects it to the output point block with a constant 90° angle. The vertical pulley is fitted with a force sensor that measures the effort on the pulley, thanks to the constant angle between the in and out portions of the cable in the pulley.

The robot is controlled using a MathWorks xPC Target based controller. As a result, control laws are designed using MATLAB and Simulink. The robot controller is connected to the posts using a real-time Ethernet bus, based on EtherCAT protocol, to which the drives of the motors are connected as well. Using this protocol, the posts can be up to 100 m apart from each other. Each post is equipped with one AccurET drive from ETEL Motion Technology that is able to control the two winches of the post. These latter are actuated by brushless direct-drive servo motors. Each drive also gathers the outputs of the force sensors to send them to the controller. Between each post run the power line and an emergency stop signal pair as well.

During an initialization phase, the cable tensions are brought to levels set by the user using a basic force control loop on the winches. The controller switches to a position or to a hybrid force/position feedback control loop once the cable lengths are initialized. The tensions in the cables should be high enough for the cables to be straight. During the initialization, it may be necessary to fix the platform to the ground or, in case of fully constrained configuration, to a collapsible stand (if the platform mass is too low, for example). Let us note that this initialization phase may be simplified if absolute multi-turn encoders are used. It is not currently the case for ReelAx which uses incremental encoders.

As the first reconfiguration step implies moving the posts, it should not be carried out very frequently since the posts must be either attached to the ground or attached to ballast at its base.

The two other reconfiguration steps can be more easily carried out, and will be used extensively as illustrated in the last section of this paper, in which the different configurations that have been tested with ReelAx are presented.

3.2 Winches

The main constraint on the design of the winches was to be able to reel in and out the cable without modifying the position of the point at which the cable is drawn out from the drum. In order to fulfill this requirement, the winches have been

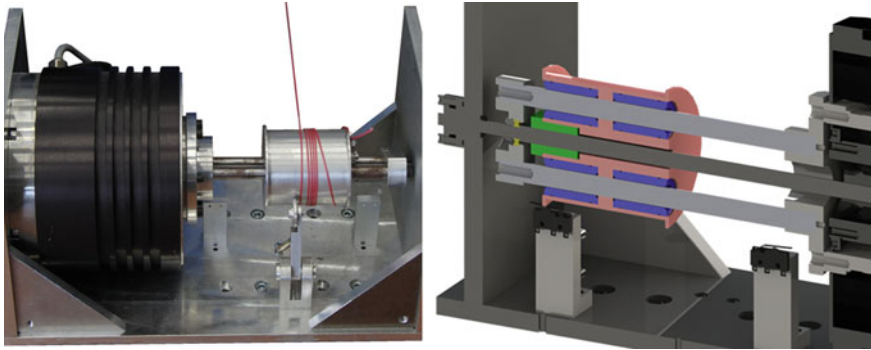

Fig. 2 Views of the first version of the winches. *Right* is a cut CAD view, with the drum part in *red*, the cylindrical bearings in *blue*, the screw nut in *green* and other turning parts in *grey*

designed with a drum having a combined translational and rotational movement so that, when the cable is wound or unwound on the drum, its exit point is kept at the same position. Several kinematic solutions have been studied, all of them using a screw/nut joint to generate the combined translational-rotational movement of the drum from the rotation of the motor. The solution has been chosen in order to optimize the compactness of the winch, regarding both the length of the winch with respect of that of the drum and the diameter of the drum. Simplicity of realization was also a concern that led to the actual design of the winch.

As shown in Fig. 2, the mechanism set in motion by the direct-drive motor uses two shafts on which sits the drum by means of two cylindrical bearings. The drum both sits on these bearings and on the nut of a ball screw, the screw being fixed to the main frame of the mechanism. As a result, the rotational motion of the motor is transmitted to the drum through the two shafts and cylindrical bearings, this rotational motion being transformed in a combined translational-rotational motion by the screw/nut joint.

Given the maximal tension in the cable of 300 N, the different parts have been dimensioned. Using a ball screw with a restrained cost implies a quite large nut, which forces the diameter of the drum up to 65 mm. Given this diameter, the motor should run at 440 rpm with a torque up to 10 Nm, preferably in direct drive: The ETEL Motion Technology direct-drive motor RTMB-140-070 has been selected. This motor has the advantage of having a hollow shaft so that the screw can run across the whole mechanism and the motor. 300 N corresponds to the maximum recommended tension in a $\varnothing 1$ mm steel wire with 1780 MPa tensile strength (50% of the breaking load), therefore the pitch of the screw has been set at 2 mm. The maximum cable diameter that may be used in ReelAx will therefore be $\varnothing 2$ mm, made of steel or other cable material such as Dyneema. With a 63 mm long drum, this corresponds to more than 6 m of cable that can be reeled in.

As shown in Fig. 3, a second version of the winch has been designed based on the experience of the first one. Indeed, the juxtaposition of the two sets of cylindrical ball

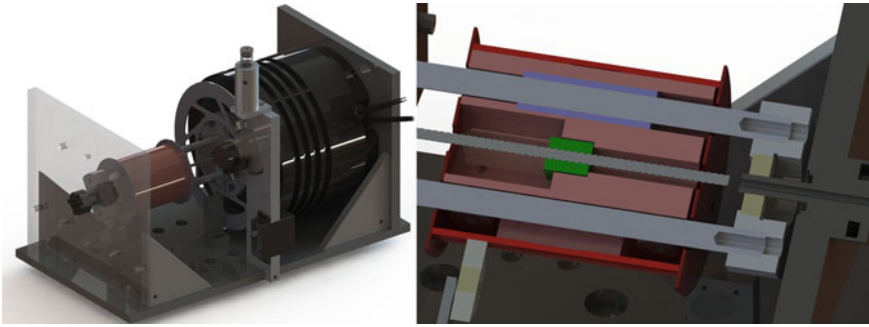

Fig. 3 *Left* CAD view of the final version of the winches; *Right* close-up on the cut view of the drum (same color coding as in Fig. 2)

bearings and the ball screw leads to an overconstrained design that induces internal forces in the mechanism and additional friction. In the second version, one of the rods is fitted with a pair of bronze bushings, while the other is held by a pair of rollers on the pulling side of the drum and a PTFE cushion on the other side, with a clearance of 0.5 mm. Using smaller rods, this could have led to smaller drums; however, we chose to keep the same drum outer diameter than the previous design in order not to change the speed and torque of the motor for a given tension and speed at the level of the cable. The ball screw has been replaced by a smaller screw with a low-friction Haydon-Kerk nut. In this second version of the winches, a notable difference is that the screw does not run through the whole mechanism. It is held on the side of the motor only. Misalignment is therefore compensated for by the flexibility of the screw induced by the long cantilever arm between the nut and the screw holding position (at least 170 mm) and the screw small diameter ($\text{\O}3.3$ mm). These nuts also exist in 1 and 0.5 mm pitch, which would allow reeling in longer cables if needed in future applications, with the constraint of using smaller cables. In addition, changing the screw pitch in the assembly requires little investment.

Moreover, a current loss brake system has been set in place for all of the winches. In addition, considering the poor behavior of Dyneema cables under stress (creeping, low breaking force when loaded for several hours) and in order to test the effect of sagging cables, the cables have been replaced by steel cables with a diameter of 1 mm and a breaking load of 600 N.

3.3 Output Blocks: Cable Exit Points

The output blocks shown in Fig. 4 have been designed with the following objectives: to provide a wide range of possibilities for the positioning of the output points for reconfigurability, to ensure that the positions of the output points do not change over

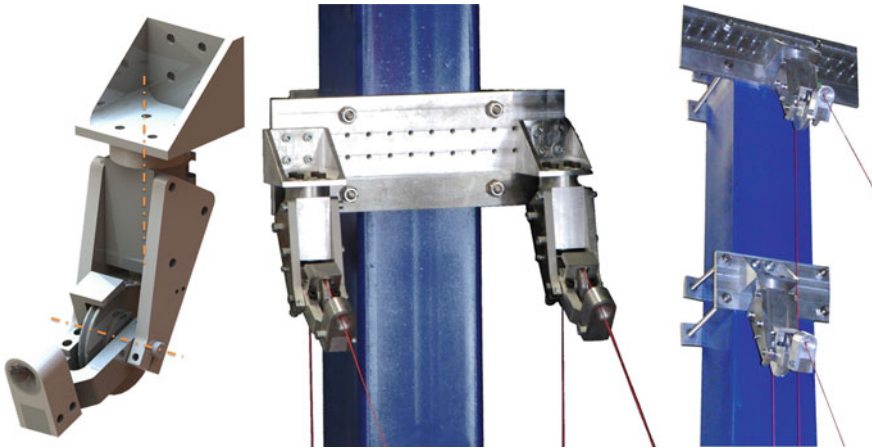

Fig. 4 Left to right CAD view of the output blocks, with orange lines showing the axes of rotation set by the user; two different configurations of the output blocks

time and to maintain the cable routing steady whatever the position and orientation of the robot mobile platform.

The reconfigurability constraint has been addressed by designing a generic output block that may be placed wherever it is needed on the post. In order to fix it, milled plates have been designed with an array of holes for placing and maintaining in place the output block. On each post, it is possible either to place the two pulleys on the same plate, thereby positioning the two output points at the same height separated by a distance from 75 to 300 mm (central picture in Fig. 4), or else to place them on different plates that may be clamped anywhere along the post, up to 3 m high (right picture in Fig. 4).

In each output block, the cable first comes in contact with a freewheeling pulley. This pulley is fixed on a part which can be turned around an axis materialized by the vertical part of the cable coming from the drum. The orientation of this rotating part is set by the user and held in place by a set of screws. The cable is then redirected toward any point in the workspace by means of an eyelet. This latter is a part having a pseudosphere shape obtained by revolving a portion of circle around its tangent, the tangent being the axis of the cable coming from the pulley. The cable sits and slides on this pseudosphere shaped part when pulled. The output point is considered to be where the axis of the cable and the circle generating the pseudosphere intersect (Fig. 5). In order to optimize the output point position, the user can set the eyelet towards the centre of the workspace by means of a user defined rotation about a horizontal axis as shown in the (left part of Fig. 4).

In order to have a strictly constant output point from which the length of the cable can be computed using the distance between this point and the attachment point on the mobile platform, the last part should feature a pseudosphere generated by a circle with a null radius. This is obviously not possible as it would severely

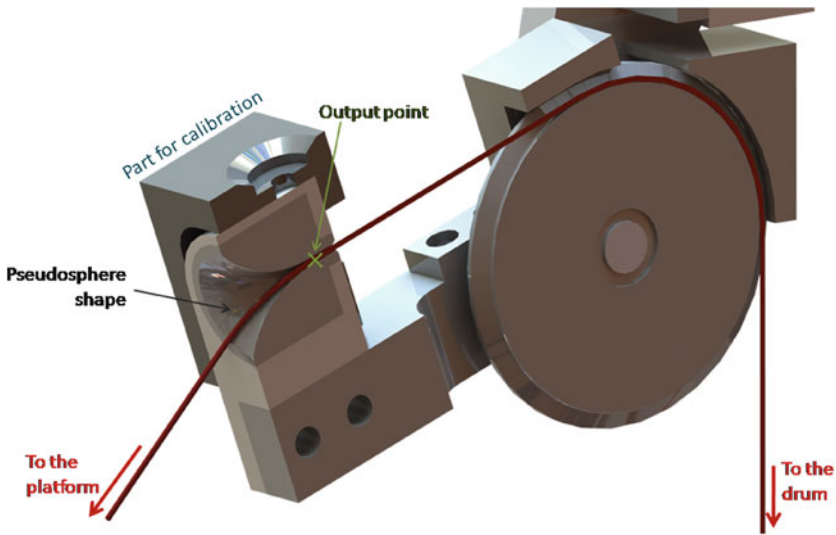

Fig. 5 Cut CAD view of the eyelet in the pulley assembly showing the elements of the eyelet

damage the cable when it runs on the eyelet. The radius has been set at 10 times the maximum cable diameter which is equal to 2 mm (corresponding to the pitch of the winch screw) that is to 20 mm. The maximum deflection angle is of 60° . With this design, the error between the distance separating the attachment point and the output point (taken as the cable length in the control law) and the actual cable length is 3.5 mm error on the cable length when the attachment point distance to the eyelet is 400 mm (the typical dimension of a platform) and the deflection of the cable at 60° from the revolution axis the pseudosphere. The error is less than 1.5 mm when this angle is 45° at the same conditions, which may happen when the workspace is square or rectangular with the posts at the corners.

Calibration of the position of the output points has been done using a laser tracker system. A specifically designed part, featuring cavities with magnets for placing the laser tracker target, is placed on the eyelet during the measures. This part is shown in Fig. 5.

4 Tested Configurations

4.1 ReelAx6: 6 Cable Suspended Triangle Configuration

The first tested configuration of the reconfigurable robot ReeAx was a suspended underconstrained configuration with 6 cables and 3 posts called ReelAx6 (Fig. 6). The mobile platform having 6 degrees of freedom (DOF), the robot was not redundantly

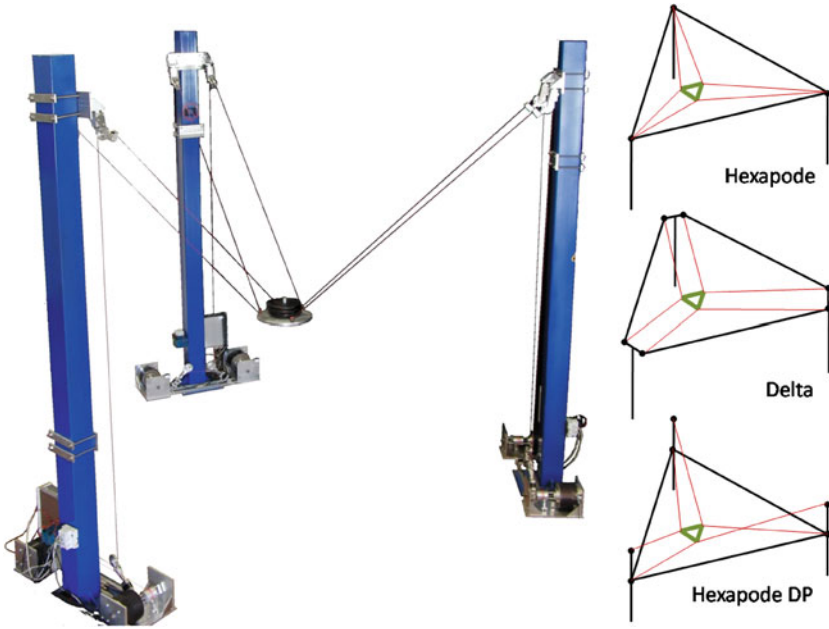

Fig. 6 ReelAx6 global view (*left*) and the three tested configurations (*right*)

actuated. The posts are placed at the vertices of an equilateral triangle measuring 3 m on each side. Its original purpose was to compare several typical geometries of parallel kinematic machines in the case of a parallel cable-driven parallel robot with a triangular footprint and a planar platform.

ReelAx6 used the first version of the winch design (Fig. 2) and the cables were Dyneema cables. The controller was very basic allowing us only to provide waypoints to each motor. To coordinate the movements of the winches, the trajectory was thus separated into several small continuous parts.

4.2 ReelAx 2D Paint: Redundant Fully Constrained Planar 2-DOF

The first reconfiguration of ReelAx occurred for a joint experimentation with the Ecole des Beaux-Arts, during which art students were to use new technologies to carry out creative art. The goal of the experiment was to reproduce famous paintings using a parallel cable-driven robot, which led us to change the design of ReelAx6 into a planar fully constrained design. The mobile platform was working in the vertical plane delimited by two posts from the ReelAx6 configuration (Fig. 7).

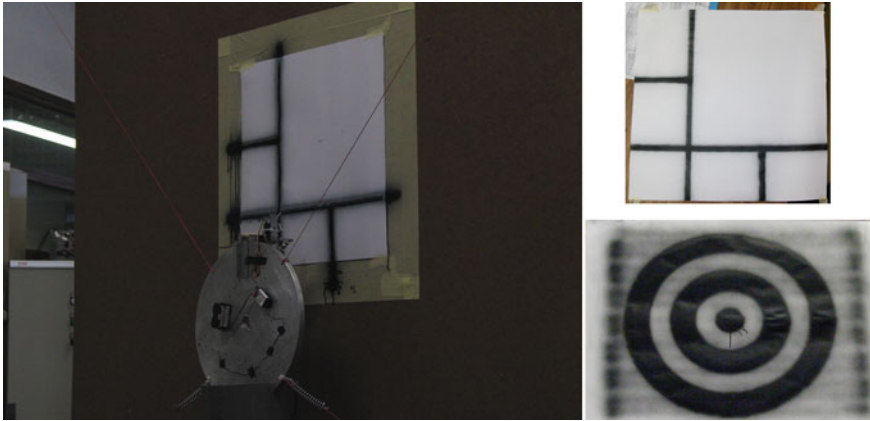

Fig. 7 View of the 2D paint configuration during operation. *Right pictures* show works painted using the robot, inspired by original works by Mondrian and Jasper Johns

Paint was delivered to the platform through an umbilical, and the operation of the paint spray gun was carried out remotely by the user.

In order to deal with the redundancy using the drives that, at this time, were not able to carry out torque control on the motors, the bottom cables have been attached to the mobile platform using springs. The flexibility thereby added allowed the use of the same basic control strategy as in ReelAx6.

4.3 Media-TIC: Redundant Fully-Constrained 6-DOF

ReelAx has also been reconfigured with an additional post and two winches in order to deal with redundantly actuated parallel cable robots. Cables are now steel cables, and the two added winches have been designed with the new version shown in Fig. 3.

The corresponding cable robot prototype has been called ReelAx8. The goal of the first studied configuration was to validate the ReelAx8 design with control laws that have been developed in the state of the art. The configuration chosen for these primary tests was a fully constrained 8 cable configuration (Fig. 8).

The goal of this research was also to validate the control laws foreseen to be used in a parallel cable-driven robot to be installed on the facade of an emblematic building of the city of Barcelona in Spain, the Media-TIC building. This project is currently in waiting for the construction permits to carry on the installation of the robot.

The control law that has been selected for its simplicity was developed by Lafourcade [11] for the SACSO robot, integrates two control parameters: the geometric target position, for following the trajectory, and the desired mean tension in the cables. In the case of the Media-TIC robot, the energy consumed is provided

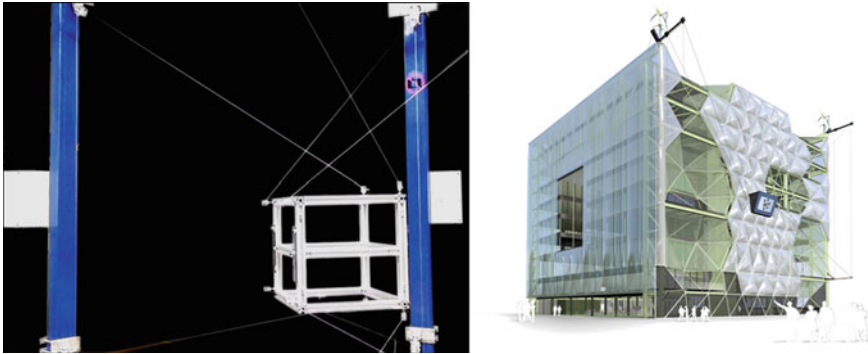

Fig. 8 *Left* the ReelAx8 fully-constrained configuration under testing. *Right* artist view of the Media-TIC building with a parallel cable-driven robot installed on one of its facades

by windmills: the mean tension parameter is therefore used to increase the lateral stiffness of the robot when wind is blowing to resist effects of gusts, which also increases the energy consumption. When wind is low, the energy consumption has to be decreased and the lateral stiffness is lower.

4.4 *ReelAx8: CoGiRo*

In the framework of the CoGiRo ANR project [12], an example of application has been suggested for the design of a parallel cable robot prototype, namely the transportation of loads over about 10 m, with optimization of the design to have the best robustness to non-centered loads. This leads us to the ReelAx8–CoGiRo design shown in Fig. 9 [13]. The robot overall occupied space measures $4 \times 3 \times 3 \text{ m}^3$ ($L \times l \times h$), while its platform is a cube measuring 400 mm in edge, weighting 6.2 kg. It is actuated with $\varnothing 1$ mm steel cables.

This ReelAx8 design has since been used to perform preliminary tests, notably of control laws, in prevision of the large size CoGiRo prototype shown in the bottom image of Fig. 9.

The final design of the CoGiRo prototype is a 16 m long, 12 m large, 6 m high cable-driven parallel robot, which should be able to lift a 500 kg payload at 2 m above the ground within a $10 \times 8 \text{ m}^2$ rectangle. It is actuated by $\varnothing 4$ mm cables, and features a self-supporting frame made of aluminium truss elements. The robot mobile platform is a cube measuring 1 m on the side. This design can cope with payload off-centered by 0.275 m, which is the best performance among 20738 configurations studied.

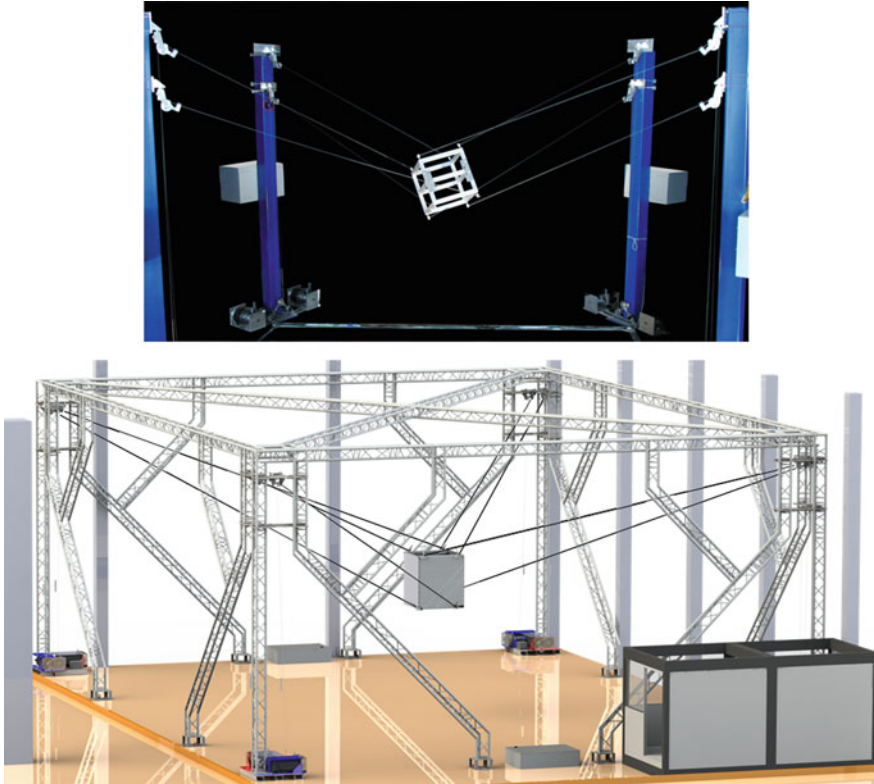

Fig. 9 *Top* ReelAx8 in a suspended redundantly actuated configuration (8 cables, 6 DOF), a preparation for the CoGiRo prototype shown in the *bottom* CAD image

4.5 ReelAx8 Light

A specific test on ReelAx8 related to the research topics of the ANR project CoGiRo has been carried out by changing the platform and checking the corresponding modifications of the robot. The main modification was to use a very light platform, in order to enhance the effects of sagging. It was made of balsa wood, and weights only 160 g, while the weight of all the cables deployed at the test position was around 140 g (Fig. 10). As a reminder, the weight of the platform in the original version of ReelAx8 was 6.2 kg.

The test carried out both with the normal and the light platform was to measure the local stiffness of the robot by pulling with a calibrated force on the platform in various directions and measuring the induced displacements in the same directions. Further work includes the development of a cable model including the effect of sagging in order to correlate with these results, based on the measurement of the sagging curve of a single cable.

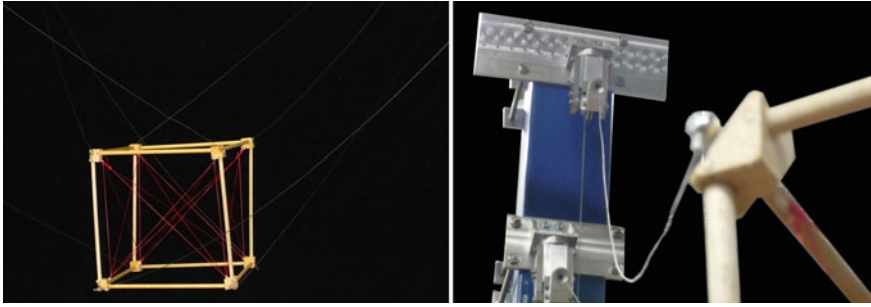

Fig. 10 Views of the ReelAx8 robot with very the light platform. The *right picture* shows a view in the line of sight between an attachment point and the corresponding output point, showing the sagging of the cable

5 Conclusion

This paper presented the LIRMM-Tecnia reconfigurable parallel cable-driven robot called ReelAx. The robot main characteristics, e.g. footprint, mobile platform geometry and drawing point layout can be modified, making it particularly suitable for studying new configurations or novel control laws as well as various application scenarios. The main components of ReelAx were presented in some technical details together with the various configurations of ReelAx tested so far.

Ongoing and future works are mainly focused on the ReelAx8–CoGiRo suspended redundantly-actuated configuration. The control of such a redundant under- constrained parallel cable-driven robot configuration is a challenging task. We thus plan to test various control schemes and to compare their performances and relative advantages. We also plan to make ReelAx8 perform pick-and-place tasks across its large workspace by embedding a gripper onto its mobile platform.

Acknowledgments The financial support of the ANR (grant 2009 SEGI 018 01) and of the Région Languedoc-Roussillon (grants 115217) are greatly acknowledged.

References

1. Kawamura, S., Choe, W., Tanaka, S., Pandian, S.R.: Development of an ultrahigh speed robot FALCON using wire drive system. In: IEEE International Conference on Robotics and Automation, Nagoya (1995). doi:[10.1109/ROBOT.1995.525288](https://doi.org/10.1109/ROBOT.1995.525288)
2. Albus, J., Bostelman, R., Dagalakis, N.: The NIST robocrane. *J. Robotic Syst.* **10**(5), 702–724 (1993)
3. Tadokoro, S., Verhoeven, R., Hiller, R., Takamori, T.: A portable parallel manipulator for search and rescue at large-scale urban earthquakes and an identification algorithm for the installation in unstructured environments. In: IEEE/RSJ International Conference on Intelligent Robots and Systems, Kyongju (1999)

4. Merlet, J.-P.: Kinematics of the wire-driven parallel robot MARIONET using linear actuators. In: IEEE International Conference on Robotics and Automation, Pasadena (2008)
5. Dewdney, P., Nahon, M.A., Veidt, B.: The large adaptive reflector: a giant radio telescope with an aero twist. *Can. Aeronaut. Space J.* **48**(4), 239–250 (2002)
6. SkyCam. <http://skycam.tv/>
7. SpyderCam. 2012. <http://spydercam.com/>
8. Lafourcade, P., Llibre, M., Reboulet, C.: Design of a parallel wire-driven manipulator for wind tunnels. In: Gosselin, M., Ebert-Uphoff, I. (eds.) *Workshop on Fundamental Issues and Future Research Directions for Parallel Mechanisms and Manipulators*, pp. 187–194, Quebec City (2002)
9. Hiller, M., Fang, S., Mielczarek, R., Verhoeven, R., Franitza, D.: Design, analysis and realization of tendon-based parallel manipulators. *Mech. Mach. Theory* **40**(4), 429–445 (2005). doi:[10.1016/j.mechmachtheory.2004.08.002](https://doi.org/10.1016/j.mechmachtheory.2004.08.002)
10. Pott, A.: An algorithm for real-time forward kinematics of cable-driven parallel robots. In: Lenaršič, J., Stanišič, M. M. (eds.) *Advances in Robot Kinematics: Motion in Man and Machine*, vol. 8, pp. 529–538. Springer, Heidelberg, (2010). doi:[10.1007/978-90-481-9262-5_57](https://doi.org/10.1007/978-90-481-9262-5_57)
11. Lafourcade, P.: Contribution à l'étude de manipulateurs parallèles à câbles, application à la conception d'une suspension active pour soufflerie. Ph. D. thesis, ONERA-DCSD, Toulouse (2004)
12. CoGiRo Project. <http://www2.lirmm.fr/cogiro/>
13. Riehl, N.: Modélisation et conception de robots parallèles à câbles de grande dimension. Ph.D. thesis, Université Montpellier II, Montpellier (2011)