



HAL
open science

Presentation of the MTCube CubeSat Project

Viyas Gupta, Luigi Dilillo, Frédéric Wrobel, Ali Mohammad Zadeh, Muriel Bernard, Georgios Tsiligiannis, Laurent Dusseau, Valérie Ponsa, Jean-Roch Vaillé

► **To cite this version:**

Viyas Gupta, Luigi Dilillo, Frédéric Wrobel, Ali Mohammad Zadeh, Muriel Bernard, et al.. Presentation of the MTCube CubeSat Project. 4S Symposium 2014 - Small Satellites Systems and Services, European Space Agency (ESA); Centre National d'Etudes Spatiales (CNES), May 2014, Majorca, Spain. lirmm-01272951

HAL Id: lirmm-01272951

<https://hal-lirmm.ccsd.cnrs.fr/lirmm-01272951>

Submitted on 28 Feb 2023

HAL is a multi-disciplinary open access archive for the deposit and dissemination of scientific research documents, whether they are published or not. The documents may come from teaching and research institutions in France or abroad, or from public or private research centers.

L'archive ouverte pluridisciplinaire **HAL**, est destinée au dépôt et à la diffusion de documents scientifiques de niveau recherche, publiés ou non, émanant des établissements d'enseignement et de recherche français ou étrangers, des laboratoires publics ou privés.

PRESENTATION OF THE MTCUBE CUBESAT PROJECT

V. Gupta⁽¹⁾, L. Dilillo⁽²⁾, F. Wrobel⁽¹⁾, A. Zadeh⁽³⁾, M. Bernard⁽⁴⁾, G. Tsiligiannis⁽²⁾,
L. Dusseau^(1,4,5), V. Ponsa^(1,4), J.-R. Vaillé^(1,6)

⁽¹⁾ *Institut d'Electronique du Sud/Radiac, Université Montpellier II / CNRS, UMR-CNRS 5214, Place Eugene Bataillon - 34095 Montpellier Cedex 5, France, +33(0)634117386/+33(0)467143825, {viyas.gupta, laurent.dusseau, valerie.ponsa}@univ-montp2.fr,*

{frederic.wrobel, jean-roch.vaille}@ies.univ-montp2.fr,

⁽²⁾ *Laboratoire d'Informatique, de Robotique et de Microélectronique de Montpellier (LIRMM) Université de Montpellier II/CNRS, 161 rue Ada - 34095 Montpellier Cedex 5, France, +33(0)467418526, email:{dilillo, tsiligiann}@lirmm.fr*

⁽³⁾ *European Space Agency (ESA), Keplerlaan 1, PO Box 299, NL-2200 AG Noordwijk, The Netherlands, +31(0)715655894, ali.mohammadzadeh@esa.int*

⁽⁴⁾ *University Space Center Montpellier Nîmes, CC 083 - Place Eugène Bataillon. 34095 Montpellier Cedex 5 - France, +33467143904, muriel.bernard@univ-montp2.f.r*

⁽⁵⁾ *CNRS, IES, UMR 5214, F-34000, Montpellier, France.*

⁽⁶⁾ *Université de Nîmes, Site des Carmes, Place Gabriel Péri, 30000 Nîmes, France.*

ABSTRACT

In this paper, we will present the MTCube project, with a focus on the preliminary considerations regarding the payload which will consist in flying different types of state-of-the-art COTS (Commercial Off the Shelf) memories. The objective of the mission is to assess their sensitivity with respect to SEEs (Single Event Effects) in the space environment in order to compare ground based tests results with in-flight data.

1 INTRODUCTION

The continuous technology development, improvement and miniaturization of electronic components have been advantageous to the development of spacecraft. However, the miniaturization of electronic components has led to a trend of increased sensitivity, especially considering Single Event Effects (SEE). Crucial devices in electronics are memories and it is of utmost importance to study how the new generation of memories behave and operate in space environment.

COTS (Commercial Off The Shelf) components, have already been considered for use by the space industry. They present the advantage of being at the same time cheap, low in mass and power consumption and easily purchasable compared to RadHard or military grade components. Nevertheless, as they are not designed carrying in mind their survivability in a space radiation environment, they have to be rigorously tested and characterized to ensure their reliability for space applications. While testing of memories can be performed in radiation facilities, they are not fully representative of the actual space environment, as it will be presented later. Besides, it is necessary to carry out in-flight technology demonstration of these memories in order to raise their TRL (Technology Readiness Level) for future applications in space missions.

The MTCube project, on which is proposed to fly the RES (Radiation Effect Study) Experiment, is a 1U CubeSat that aims at addressing the above. Its mission is to characterize and qualify state-of-

the art commercial memories like SRAMs, FLASHs, and emerging technologies such as MRAMs and FRAMs for future space applications. MTCube is based on the Robusta platform that has been designed and built by students of UM2 (Université Montpellier 2), thanks to the experience gained on Robusta 1A and Robusta 1B projects [1], [2].

2 COTS FOR SPACE APPLICATIONS

Since many years, electronic components used in space applications have been radiation hardened by design, by using schemes such as guard rings or triple well among others. Unfortunately, such hardening technology comes with a price: mass increases as well as power consumption and price.

In order to utilise the benefits of the emerging commercial technology like speed, low power consumption, lower mass and price, COTS components have been considered for use in space applications. This trend is closely linked to the emergence of small satellites, mainly built by Universities, such as the University of Surrey with the UoSAT serie, and thanks to improved capabilities in electronics allowing such a trend. Concerning the selection of COTS components, another important aspect, is the risk associated by the use of COTS: small satellites built by Universities are low risk missions unlike commercial or national space satellite projects. For some missions, radiation tolerance at the levels of COTS components may be considered sufficient.

As mentioned in the introduction, utilizing COTS components for space applications has been recently considered by national and international space agencies for the reasons mentioned above. In order to mitigate risks associated with the use of COTS components, several solutions may be implemented such as:

- Error Correction Codes (ECC)
- Redundancy
- Using several smaller components instead of one main component
- Periodical restarts of electronic components
- Optimizing the placement of components using other components to shield the most sensitive ones
- A combination of all the above

Depending on the space environment to which will be subjected electronic components, they may make use of the practices mentioned above. In order to evaluate the effects of radiation on the components that will be used for a specific space application, and consequently mitigate them, testing should be performed under similar conditions. Testing of components can be made in three different ways: simulation level testing, accelerated testing and real time testing. Space standards by ESA or NASA may be followed, such as [3] or [4] for SEE testing under heavy ion or proton irradiation.

One of the drawbacks of accelerated testing is its inability to be fully representative of the space environment: energies cannot reach the high energy levels found at space (always as a function of the environment the component is meant to operate) [5], synergetic effects may be not tested due to time and/or cost constraints (dose and SEE); often due to limited beam diameter only parts of the integrated components can be set under test, and not the entire system; most of the time radiation testing is performed with the beam perpendicular to the surface of the component sometimes only making an angular dependency study [6] whereas space radiation is often omnidirectional; due to time/cost constraint, radiation testing is performed at high flux that may not be representative of the space environment. Moreover, electrical degradation and temperature impact of the component after several years of mission in space environment is difficult to apprehend.

Hence, the possibility of testing components in a real space environment presents one of the best solutions that may be referred to as real-time testing. Results may provide valuable feedbacks to compare with accelerated testing results and simulation testing results, in order to evaluate how well they are representative of the actual environment.

This may also allow the improvement of the guidelines on radiation testing to improve Radiation Hardness Assurance (RHA) methodologies. In this respect, small satellites and CubeSats in particular, present a very good advantage: they present a low cost, quickly available testbed which can be used to qualify space components in complement of accelerated testing in order to characterise their response to radiation for future space missions.

3 TYPES OF MEMORIES

Memories are used for different tasks depending on their performances. For example, memories are used as storage devices for boot software and other software, cache memory for microprocessors but also storage devices for telemetry/telecommand and scientific data. In this section, we will briefly review the types of memories that may be part of the MTCube payload and briefly see what are some of the SEE sources for each type of memory.

SRAM (Static Random Access Memory) is a type of memory that has high performance in access time and it is volatile. As shown in Figure 1, the most common SRAM memory cell is based on 6 Transistors (6T) memory cell storing the bit, either '0' or '1', thanks to 4 MOS transistors connected in order to form two cross-coupled invertors (the two other transistors enable to access the memory cell) [7]. The miniaturisation trend makes necessary to constantly test the sensitivity to radiation of new technology nodes, as new type of effects may appear. For example, direct proton ionization at low proton energy are new sources of error, due to increased sensitivity and high density memory cells [8]. The number of MCUs (Multiple Cell Upsets) can considerably increase [9].

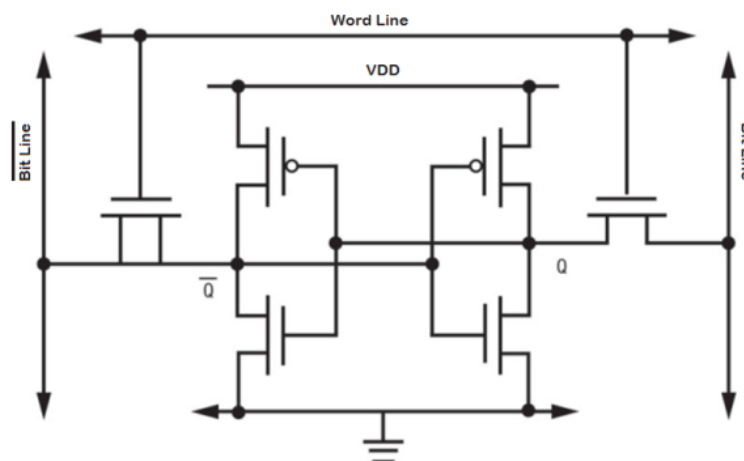

Figure 1. 6T memory cell diagram of an SRAM

FLASH memories are non-volatile memories, often used as mass data storage or used to retain the boot software for example. FLASH memory cells are less sensitive to the radiation environment compared to SRAMs, but they may still be affected, not only at cell level but also in their control circuitry. Faulty control logic may produce large cluster of errors for example during the occurrence of SEFI (Single Event Functional Interrupt). [10] provides a comprehensive list of potential effects

of heavy ions radiation on FLASH memories.

The other types of non-volatile memories such as MRAM or FRAMs appear to be interesting candidates since they present high endurance capabilities with lower access time if compared to FLASH technology. The bit storage mechanism provides a good inherent radiation robustness of the memory cells according to literature such as in [11], while most of the potential errors may arise from the CMOS based peripheral circuits. As those memories are rather new on the market of commercial memories, characterising their behaviour is essential to assess their potential use on future spacecraft.

4 SPACE RADIATION ENVIRONMENT

The harsh space radiation environment has been and remains an important aspect to be considered during the design of satellites, in order to ensure their reliability for the duration of the mission. Other environmental aspects such as vacuum, thermal, atomic oxygen in upper atmosphere, micrometeorites, charging due to plasma of electrons and protons may also be considered but are out of the scope of this paper.

Radiation is a field of energetic of high speed particles or electromagnetic waves, that can be ionizing or non-ionizing. The Earth natural ionizing space radiation environment can be divided in three generic components [12]:

- The trapped particles in the Earth's radiation belts (Van Allen belts)
- The particles originating from the Sun: solar wind, Coronal Mass Ejections, solar flares
- The Cosmic Galactic Rays (CGRs)

The Earth is surrounded by two radiation belts: the internal belt is mainly composed of protons and electrons whereas the external belt is mainly constituted of electrons. Alpha particles and heavy ions are also present but their proportion remains negligible. Figure 2 shows the extent of these radiation belts with respect to the Earth radius.

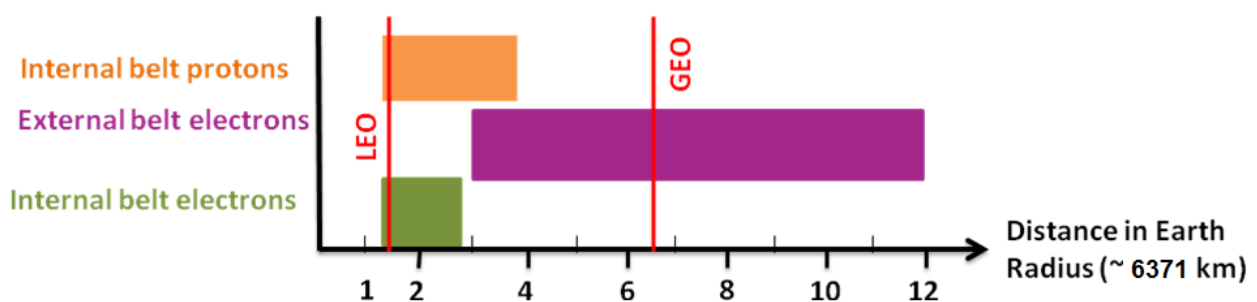

Figure 2. Altitude of the two Van Allen radiation belts. Internal belt mainly made of protons and electrons, external belt mainly made of electrons [13]

The energy and fluxes of the particles in the Van Allen radiation belts depend on the altitude and inclination. Moreover, the belts are not static but rather dynamic as they are distorted by the solar wind, affected by the Sun cycles and the Earth's rotation [14].

The Sun contributes in 3 different ways to the radiation environment of the solar system: the solar wind, the solar flare and the CMEs (Coronal Mass Ejections). The solar wind is a constant flow of electrons and protons at supersonic speed coming from the Sun. The solar flares are a more periodical event modulated by the 11 year solar cycle. Solar flares release mostly energetic protons,

but also alpha particles and heavy ions at nearly the speed of light along with electromagnetic radiation in all wavelengths. CMEs are larger events in which electromagnetic radiation as well as high energetic protons, alpha particles and heavy ions are released. High solar energetic particles can affect spacecrafts in the system solar but also spacecrafts protected by the Earth magnetic field especially spacecrafts with high inclinations and/or with higher altitudes.

Finally, CGRs originate from exploding stars in the Universe. They are considered omnidirectional and are constituted mainly of protons, alpha particles and heavy ions of very high energies in the order of GeV or higher some of which may penetrate the Earth radiation belts and affect any spacecraft in low earth orbit.

As mentioned in [15], the Space radiation environment is still being investigated and models are constantly being improved taking into account new advances in the scientific field in order to better understand their impact on constantly changing microelectronic technology.

5 RADIATION EFFECTS ON MEMORY DEVICES

The Space radiation environment, as presented in the previous section, affects microelectronics in two different ways via cumulative effects (Total Ionizing Dose, Displacement Damage) and Single Event Effects (SEEs). Effects of the particles mentioned in the previous section (protons, electrons and heavy ions) on semi-conductors are summarised in Figure 3.

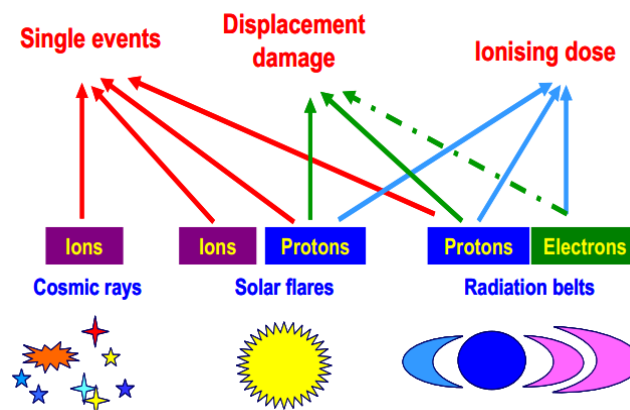

Figure 3. Comparison between radiation sources and effects [16]

The focus of the MTCube experiment as it will be presented below, are Single Event Effects mainly due to heavy ions and protons. SEEs are due to very highly energetic particles, such as protons and heavy ions from CGRs, SEP (Solar Energetic Particles) or even high energy protons from the Earth radiation belts. Those high energetic particles will pass through memory cells and matters, generating an ionized track of electron/hole pairs by two different mechanisms: direct ionization when the incoming particle generates itself electron/hole pairs; and indirect ionization when the incoming particle generates an ion recoil which will generate electron/hole pairs (Figure 4). If the ionized track is close enough to the sensitive region of a transistor (the drain), the created charges can be absorbed by the transistor and change its state (from OFF to ON). For an SRAM cell, this may induce a bit flip that can be classified as a Single Event Upset (SEU). Other types of SEE can be triggered by highly energetic particles, such as Multiple Cell Upsets (MCUs) or Single Event Latchups (SELs), amongst others.

MCUs are upsets occurring in a group of more than two adjacent cells as a result of the direct or indirect ionization of a single particle. MCUs are becoming a relevant phenomenon since the

number of involved cells involved is increasing with the density of memories.

SEL are latch ups created by the activation of an inherent PNP or NPN parasitic thyristor in CMOS technologies, triggered by an ionizing particle, leading to a high current flow in the transistor which in turn may produce a short eventually leading to the failure of the component.

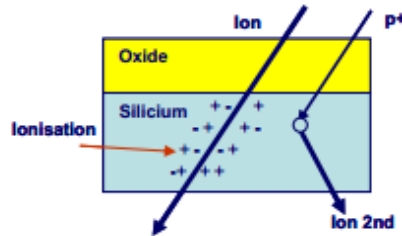

Figure 4. Basic mechanisms of radiation effects: generation of an ionizing track via direct or indirect ionization [16]

As discussed in [17], shielding of sensitive components may be done in the expense of increased mass. Shielding is only efficient in electron rich environment and not as much in proton rich environments. Besides, low energy nuclei from solar flares do not trigger a lot of SEE mechanisms. Hence, even if additional mass was not a penalty in the cost of a satellite (which is clearly not the case), shielding is not able to protect sensitive components from all radiation sources.

6 THE MTCUBE CUBESAT PROJECT

6.1 Background of the project

In Figure 5 the logos of the main actors of the MTCube project are presented. MTCube stands for Memory Test CubeSat.



Figure 5. The main actors of the MTCube project along with the logo of the project

The “Centre Spatial Universitaire” (CSU) was created by the RADIAC research group, one of the world leading groups in the field of radiation effects on electronics and part of the IES research entity formed by the collaboration of the Université Montpellier 2 and CNRS (Centre National de la Recherche Scientifique). For more than 25 years, RADIAC has been providing support to industries and agencies in this field of radiation effects by investigating basic mechanisms and providing them with accelerated test methodologies. The CSU comes from the collaboration between the RADIAC group and the IUT of Nîmes. The CSU developed the Robusta platform which followed the CubeSat standard [18].

The Van Allen foundation, aims at supporting nanosatellite activities in France, with corporate sponsorship of prestigious industrial partners such as Université Montpellier 2, Astrium, Intespace, 3D plus, ESA and CNES.

MTCube will fly different types of memories that may be used for future space applications. The selected memories will constitute the RES (Radiation Effect study by SEE) Experiment payload of MTCube which will be built under an ESA collaboration contract.

The main payload will be built by LIRMM, Laboratoire d'Informatique, de Robotique et de Microélectronique de Montpellier, which is a research laboratory run in collaboration between Université Montpellier 2 and CNRS.

6.2 Objectives of the mission

The RES Experiment will consist in flying different types of memories in order to assess their sensitivity in the space environment thus providing data to be compared with accelerated testing and simulations.

The primary objective of MTCube is hence to develop, test and fly the RES Experiment and gather data for 2 years (nominal mission duration). During the development phase, a set of COTS memories will be selected for the experiment. The RES Experiment will use the Robusta 1U CubeSat platform [1], [2].

Upon completion of the primary objective, the subsequent objectives will be:

- to assess the in-orbit radiation sensitivity (SEE) of various state-of-the-art memory devices (SEU and SEL)
- to map the SEE response of these memories along the orbit
- to compare ground based RHA processes with in-flight radiation data
- to develop and provide a technology test bed for novel memory devices
- to measure the on-orbit radiation dose by the use of an in-house built dosimeter

The MTCube CubeSat will be developed, built and tested by the CSU as a student project implying a strong education aspect. Students from all level and several disciplines will be involved and trained under the lead of a team of professors. None of the Robusta platform subsystems are off the shelf equipment bought from CubeSat manufacturers.

Finally, during the full project, best practices as close as possible to the ECSS standards will be followed especially regarding Product Assurance (PA) but taking into account the specificities of a CubeSat project.

6.3 The Robusta CubeSat Platform

The MTCube CubeSat will be based on the 1U Robusta platform developed at the Université Montpellier 2 [1], [2].

The 1U Robusta platform is built with the objective of being modular and allowing to “plug and play” the experiment board depending on the mission. Therefore the most fundamental structure of the Robusta platform consists of an in-house built 1U structure to which is mounted a motherboard.

The platform presents a common CAN Bus and Power BUS that are used by the other subsystems.

Hence, the major task of the project will be to design and build the payload, adapt the current Robusta platform to the needs of the payload, and perform environmental tests at system level in order to guarantee the good integrity of the satellite.

Two improvements between Robusta 1B and MTCube are related to the EPS (adding a micro-controller to manage intelligently the power distribution), and the Communication subsystems that are being upgraded. The Robusta 1B EPS and Communication subsystems will be implemented in MTCube.

Finally, the UM2 ground station will be the main ground station that will be used during the MTCube mission. Another secondary ground station will be the BMSTU ground station in Moscow (University of Bauman). It is possible that more ground stations may be used in collaboration with other universities but agreements are not confirmed at present.

7 MTCUBE RES EXPERIMENT PAYLOAD

7.1 Payload preliminary description

Besides the FLASH memory, we target to evaluate two recent SRAM technologies to compare the response of two technology nodes and architecture to space environment. The MRAM and FRAM are also proposed to compare the effects of a similar space radiation environment on those different commercial non-volatile memories. The final selection of the memories will be done when an exhaustive campaign of irradiation tests will be concluded.

Beyond the considered memories, the RES Experiment board will also comprise a dose monitoring system based on an OSL (Optically Stimulated Luminescence) dosimeter developed at by the RADIAC group. This OSL-NG is based on a previous OSL that flew on the ICARE instrument of the CARMEN-2 mission that flew onboard the JASON-2 CNES satellite [19].

The RES Experiment board will be designed to work fully autonomously during the nominal mission. The experiments will be run by a finite state machine (FSM implemented in a FLASH based FPGA which will be also responsible of the communications with the platform communication bus. The FPGA will include the Experiment controller, and a CAN controller. The FPGA will be coded in VHDL. The experiments will run concurrently but the experiment will adapt to the power supplied to the payload that may evolve during the satellite operation.

Besides the use of anti-latchup devices, in order to prevent any malfunctions due to the radiation environment, logic hardening methods will be used on the FPGA, as well as the CAN communication, experience and buffer controllers. The memory buffer will be hardened using a data reliability method by software. The buffer, that will store the error events detected on the memories prior to be sent to the main on-board computer subsystem, will have to be non-volatile to be able to store the data in the unlikely event of a power shutdown of the payload. Frequent resets of the FPGA will avoid any fault accumulations. A software watchdog will be added in the FPGA.

The following information will be gathered on orbit: data of the word that was corrupted along with the address, the timestamp and all additional information allowing to know during which test exactly the single events occurred. There will also be a record of the occurring latch up specifying the concerned devices as well as the timestamp of the event.

A simplified layout of the RES Experiment board is proposed on Figure 6. The FPGA will be directly connected to each memory while the FLASH memory will have a dedicated FPGA. The Voltage converter is not represented nor is the A/D converter will be used for the thermocouple measurements. Depending on space availability, it will be possible to integrate components on both sides of the PCB.

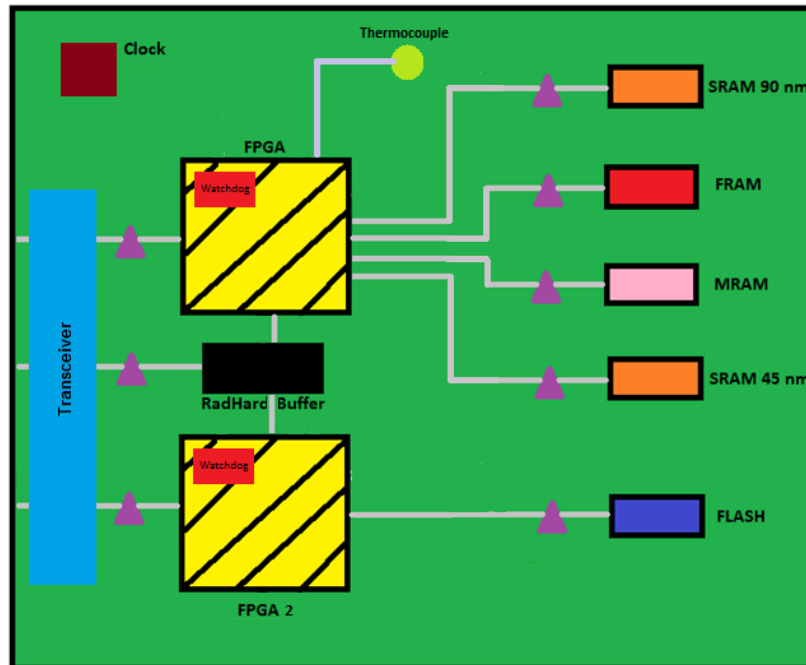

Figure 6: Layout of the proposed RES Experiment. The electrical circuitry is not represented besides the anti-latch up circuitry (the purple triangles) that will be used to count SEL on each memory.

7.2 Description of the tests performed

It is proposed that the memories shall be tested through two different types of tests. During static mode testing, a data pattern ('1's, '0's, or a combination of both) is stored in the memory cells. During the testing time, no operations are applied to the memory. After a defined time, the memory is read back and the stored data is compared with the initial one in order to detect any bit flips. On the contrary, as presented in [20], dynamic testing stresses more the memory by successive read and write operations on the memory cells during the actual testing, increasing their sensitivity to radiation. For SRAMs, this operational mode is more realistic as the memory is often used as a cache memory requiring constant access to its data. One of the advantages of dynamic mode testing is its ability to assess the sensitivity of the peripheral circuitry which is constantly solicited during read/write operations, which is not the case in static mode testing. In [21], different dynamic patterns have been applied under neutron beam irradiation and the same patterns are being tested under heavy ion and proton beams [22].

A scheduler will be responsible for a round robin scheme which will apply dynamic mode testing consecutively to all the memories while the others will be in static mode testing. This allows to obtain a homogeneous test time for the different devices and minimize the power consumption. The data will be processed by the FPGA and detected errors will be stored on a hardened memory buffer.

7.3 Selection of the tested memories

Initial radiation tests of memories have been initiated in order to better characterise the memories and select the most suitable commercial memories for the RES Experiment. Currently, two radiation tests have been made at the RADEF facilities at the University of Jyväskylä in Finland [22], one with heavy ions and the other one with protons. The test setup and some results of heavy ions irradiation campaign are presented in Figure 8. During these tests, different types of SRAMs and a FRAM memory were tested under heavy ions [23]. Further tests will be performed to other types of memories in the next few months.

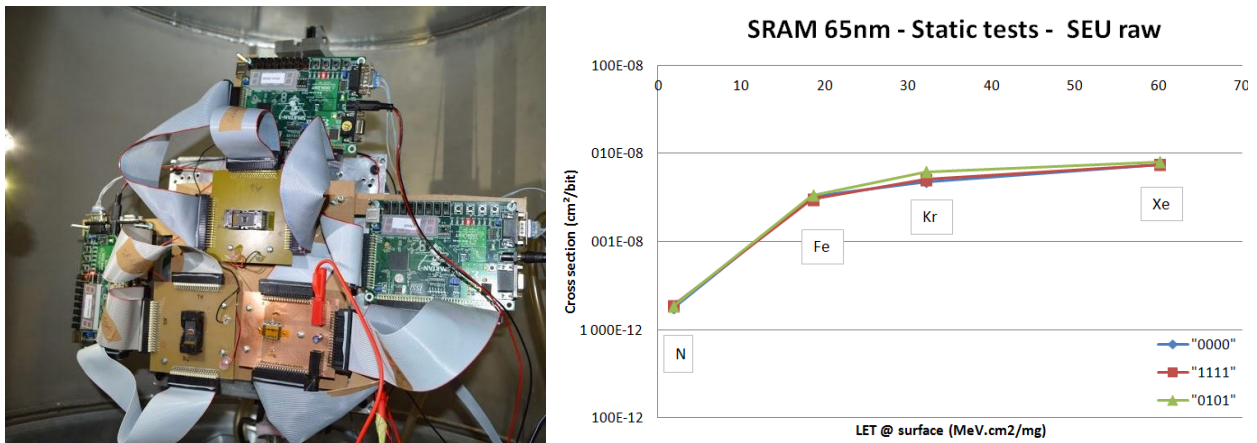

Figure 8: (left) test set-up for radiation testing, (right) cross section curve of the SRAM 65 nm under Heavy Ion irradiation.

Those tests will allow to extensively characterise the sensitivity of memories against SEEs. This will then allow obtaining the cross-section curve of the memories enabling to estimate the probability of a SEE for a particular type of energetic particle. This can then be extrapolated to the energetic radiation spectrum of the space environment to assess SEE probability for the mission. In-flight data will also provide feedbacks on those simulation tools in order to compare assumptions made by those simulation tools such as, for example, the sensitive volume depth.

7.4 Further steps

Some additional irradiation campaigns are planned to test all the potential memory candidates to heavy ion and protons at energy and flux levels representative of the space environment as well as to test the other devices that will compose the payload. Simulation will be performed to better understand the mechanism triggering SEEs. Thanks to the characterization of the memories by beam tests, an estimation of the number of SEUs will be performed through the tools OMERE, SPENVIS, MC-Oracle [24] and other simulation tools.

The RES Experiment card will be designed and fully verified through functional and irradiation tests. In the meantime, improvements on the Robusta platform will be implemented, while the search for a suitable launcher will be made.

8 CONCLUSION

In this paper, we have briefly presented the space radiation environment and its effects on memories, focusing on SEEs. We have highlighted the crucial relevance of testing memories for future space applications. Then, we have introduced and detailed the MTCube project. The main goal of this project is to retrieve in-orbit data from state-of-the-art memories in order to assess their sensitivity under real space environment and compare with on-ground test results and simulations. A major focus will put on SEE and those events that will be investigated during the nominal 2 year mission of MTCube. The low cost and short development time a CubeSat based platform will allow targeting such important objectives at academic level.

9 ACKNOWLEDGEMENT

This work was funded by Labex NUMEV.

10 REFERENCES

- [1] C. Deneau, N. Roche, S. Jarrix, and L. Dusseau, *Robusta the firstborn French modular Cubesat*, proceedings Small Satellite Systems and Services, Funchal, Madeira, Portugal, 31 May - 4 June 2010.
- [2] S. Perez, C. Deneau, N. J-H. Roche, M. Bernard, L. Dusseau, S. Jarrix, *Concepts for Modularity and Standardization of Electronic Boards on Small Satellites*, IAC 61th conference (International Astronautical Congress), Prague, Czech Republic, 27 Sept. - 1er Oct. 2010.
- [3] *Single Event Effects Test Methods and Guidelines*, ESCC Basic Specification No. 25100, Issue 1, October 2012.
- [4] *Test Procedures for the Measurement of Single-Event Effects in Semiconductor Devices from Heavy Ion Irradiation*, JEDEC Test Standard, No 57, December 1996.
- [5] V. Ferlet-Cavrois, *Influence of Beam Conditions and Energy for SEE Testing*, IEEE Transactions On Nuclear Science, Vol. 59, No. 4, August 2012.
- [6] A. D. Tipton, *Device-Orientation Effects on Multiple-Bit Upset in 65 nm SRAMs*, IEEE Transactions On Nuclear Science, Vol. 55, No. 6, December 2008.
- [7] R.C. Baumann, *Radiation-Induced Soft Errors in Advanced Semiconductor Technologies*, IEEE Transactions on Device and Materials Reliability, Vol. 5, No.3, Sept 2005.
- [8] R.K. Lawrence et al., *Soft Error Sensitivities in 90 nm Bulk CMOS SRAMs*, Radiation Effects Data Workshop, July 2009.
- [9] E. H. Cannon et al., *Multi-Bit Upsets In 65nm SOI SRAMs*, CFP08RPS-CDR 46th Annual International Reliability Physics Symposium, Phoenix, 2008.
- [10] M. Bagatin et al., *Key Contributions to the Cross Section of NAND Flash Memories Irradiated With Heavy Ions*, TNS, Vol. 55, No. 6, December 2008.
- [11] T. Nuns et al., *Evaluation of Recent Technologies of Nonvolatile RAM*, IEEE Transactions On

Nuclear Science, Vol. 55, No. 4, August 2008.

[12] J.H. Adams et al., *Cosmic ray effects on microelectronics, Part 1: The near-earth particle environment*, August 1981 referenced in A. Holmes-Siedle and L. Adams, *Handbook of Radiation Effects*, 1993, Oxford Science Publications, p.18.

[13] C. Deneau, *Développement d'un dosimètre OSL intégré sur satellite pour la mesure de l'environnement radiatif spatial*, Thesis manuscript, Decembre 2012.

[14] NASA/Goddard Space Flight Center, Earth's radiation belt: Van Allen probes reveal 'zebra stripes' in space, <http://www.sciencedaily.com/releases/2014/03/140319153200.htm>, March 19 2014, last accessed on 06/04/2014.

[15] J. L. Barth, Senior Member , IEEE, C. S. Dyer, and E. G. Stassinopoulos, Member, *Space, Atmospheric, and Terrestrial Radiation Environments*, IEEE Transactions On Nuclear Science, Vol. 50, No. 3, June 2003.

[16] R. Ecoffet, *Spacecraft Anomalies Associated with Radiation Effects*, RADECS 2013 Short Course Proceedings Chap. VIII, 2013.

[17] J. R. Schwank, M.R. Shaneyfelt, and P.E. Dodd, *Radiation Hardness Assurance Testing of Microelectronic Devices and Integrated Circuits: Radiation Environments*, Physical Mechanisms, and Foundations for Hardness Assurance, IEEE Transactions On Nuclear Science, Vol. 60, No. 3, June 2013.

[18] *CubeSat Design Specification*, Cal Poly SLO, Rev. 12.

[19] C. Deneau, J.R. Vaille, F. Bezerra, E. Lorfèvre, R. Ecoffet, L. Dusseau, *A compact dosimeter for space applications*, Real Time Conference (RT), June 2012.

[20] A. Bosio, L. Dilillo, P. Girard, S. Pravossoudovitch, A. Virazel, *Advanced Test Methods for SRAMs -Effective Solutions for Dynamic Fault Detection in Nanoscaled Technologies*, Springer Ed. (2009) 978-1-4419-0937-4 171.

[21] G. Tsiligiannis et al., *Evaluation of test algorithms stress effect on SRAMs under neutron radiation*, in Proc. IEEE International On-Line Testing Symposium (IOLTS), pp.121-122, 2012.

[22] A. Virtanen, R. Harboe-Sorensen, A. Javanainen, H. Kettunen, H. Koivisto, I. Riihimaki, *Upgrades for the RADEF Facility*, IEEE Radiation Effects Data Workshop, pp. 38-41, July 2007

[23] G. Tsiligiannis, L. Dilillo, V. Gupta, A. Bosio, P. Girard, A. Todri, A. Virazel, H. Puchner, A. Bosser, A. Javanainen, A. Virtanen, F. Wrobel, L. Dusseau and F.Saigné, *Efficient Dynamic Test Methods for COTS SRAMs Under Heavy Ion Irradiation*, selected for poster presentation NSREC 2014, July 2014.

[24] F. Wrobel, F. Saigné, *MC-ORACLE: A tool for predicting Soft Error Rate*, Computer Physics Communications, 182 (2011) 317–321.