



HAL
open science

A Simple Conditioner for Resonant Intraocular Pressure Sensor

Fabien Soulier, Frédérick Mailly, Vincent Kerzérho, Anthony Deluthault,
Serge Bernard, Philippe Cauvet

► **To cite this version:**

Fabien Soulier, Frédérick Mailly, Vincent Kerzérho, Anthony Deluthault, Serge Bernard, et al. A Simple Conditioner for Resonant Intraocular Pressure Sensor. EUROSENSORS, Sep 2016, Budapest, Hungary. pp.67-70, 10.1016/j.proeng.2016.11.149 . lirmm-01426019

HAL Id: lirmm-01426019

<https://hal-lirmm.ccsd.cnrs.fr/lirmm-01426019>

Submitted on 4 Jan 2017

HAL is a multi-disciplinary open access archive for the deposit and dissemination of scientific research documents, whether they are published or not. The documents may come from teaching and research institutions in France or abroad, or from public or private research centers.

L'archive ouverte pluridisciplinaire **HAL**, est destinée au dépôt et à la diffusion de documents scientifiques de niveau recherche, publiés ou non, émanant des établissements d'enseignement et de recherche français ou étrangers, des laboratoires publics ou privés.



Distributed under a Creative Commons Attribution - NonCommercial - NoDerivatives 4.0 International License



30th Eurosensors Conference, EUROSENSORS 2016

A simple conditioner for resonant intraocular pressure sensor

F. Soulier^{a,*}, F. Mailly^a, V. Kerzérho^a, A. Deluthault^a, S. Bernard^a, P. Cauvet^b

^aLIRMM-University of Montpellier, 161 rue Ada, 34095 Montpellier, France

^bOphthalmia, 5 esplanade Anton Philips Campus EffiScience, 14460 Colombelles, France

Abstract

Intra-ocular pressure sensors embedded in contact lenses will be of great benefit to long-term treatments of glaucoma. This paper focuses on the resonant type of this kind of sensor and proposes a minimal power consuming conditioning. The system is based on the harmonic oscillator principle and uses very few discrete components to realize a proof of concept. After the description of the eye-care professionals identified needs, we present the sensing principle, and give details on the realized circuit. Brief results are given with signal capture from a prototype to validate the concept.

© 2016 The Authors. Published by Elsevier Ltd. This is an open access article under the CC BY-NC-ND license

(<http://creativecommons.org/licenses/by-nc-nd/4.0/>).

Peer-review under responsibility of the organizing committee of the 30th Eurosensors Conference

Keywords: Analog signal; capacitive; resonating; passive; conditioning; biomedical; glaucoma; pressure.

1. Introduction

Glaucoma is a degenerative optic neuropathy that affects more than 60 millions of people and is the second cause of blindness over the world [1]. It is known that a high intra-ocular pressure (IOP) often rises the risk of the disease. Thus the treatment includes medication aimed to lower the IOP. Unfortunately, the efficiency of these treatments decreases with time, resulting in higher doses and several side effects. Then regular monitoring of IOP must be carried on to adapt the treatment. This is done thanks to a *tonometer*, a quite bulky instrument by eye-care professionals.

The main problem with this procedure is that it can only provide a punctual measure of the IOP whereas it is known to vary on a 24-hour cycle and with significant differences between healthy and glaucomatous subjects [2]. To deal with this, active sensors embedded in contact lenses have been developed [3], notably by the *Sensimed* company. More recently, the *Ophthalmia* company designed a portable IOP sensor in the form of a passive resonant circuit embedded in a soft contact lens (fig. 1). The resonant frequency of the equivalent RLC circuit belongs to the 27 MHz ISM band (fig. 2) and varies linearly with the deformation of the cornea caused by the IOP variations. The conversion rate being approximately 330 Hz/mmHg [4].

* Corresponding author. Tel.: +33-467-149-764; fax: +33-467-418-585.

E-mail address: Fabien.Soulier@lirimm.fr

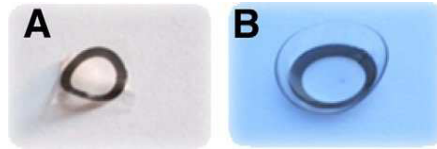

Fig. 1. The passive sensor before (A) and after (B) encapsulation in a soft eye lens. Courtesy of *Ophthalmia* company.

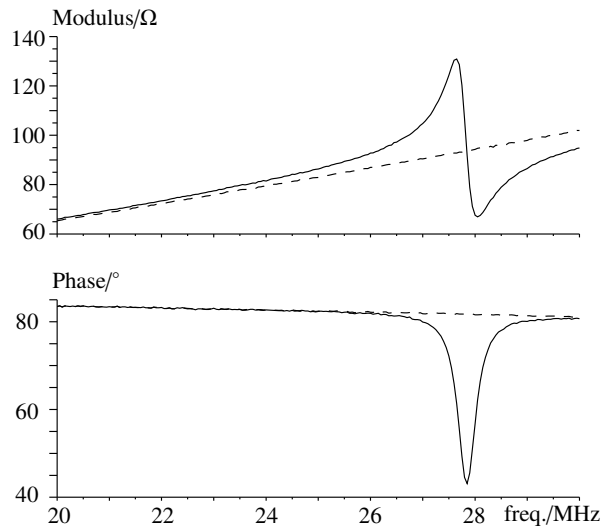

Fig. 2. Measured impedance (modulus and phase) of the sensor-coupled antenna (solid line) and of the non-coupled antenna (dashed line).

2. Conditioning system

To be of wide acceptance, the whole system must perform repetitive contactless measures of the sensor resonant frequency for more than 24 hours, while keeping a relatively small form factor. This implies quick and low-power conditioning. We meet these needs by using a near-field inductive coupling of the sensor with an antenna located on a pair of glasses. The very small electronic circuit and battery can easily fit in the glass branches.

We design the conditioner system as a harmonic oscillator. Thus, a IOP acquisition can be done with a simple measure of the oscillator frequency. The resonant part of the circuit must be the antenna coupled with the sensor. Unfortunately, the equivalent impedance does not present a directly exploitable resonance (fig. 2). Instead, we choose to use the differential impedance (ΔZ) between the coupled antenna and the same antenna but without any sensor. This differential impedance exhibits a maximum that can be used as the oscillator operating point (fig. 3).

This approach leads to the differential structure of the fig. 4. Two identical current sources are connected to antennas. The voltage difference between the antennas then depends linearly to ΔZ . It is amplified and back-fed to the current-source inputs.

An equivalent single-input, single-output model can be deduced from the differential structure (fig. 5). This is the classical positive-feedback closed-loop model of a harmonic oscillator. This structure can generate spontaneous oscillations provided that the Barkhausen's criterion is met.

$$G G_m \Delta Z = 1. \quad (1)$$

This relation is used to adjust the gain G . Practically, the gain must be slightly over-tuned in order for the oscillations to start and to compensate potential weaker coupling.

The circuit itself only uses four large-band op-amps and some matched resistors (fig. 6) to realize a harmonic oscillator. The design mimics the model of fig. 4. The leftmost op-amps form the differential voltage amplifier stage.

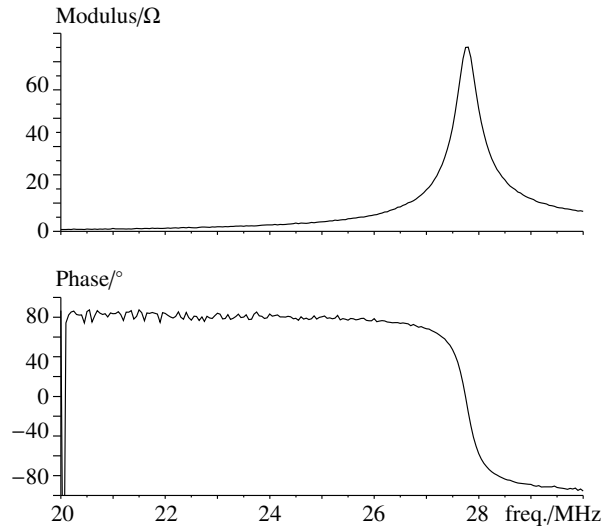

Fig. 3. Impedance difference between the coupled and non-coupled antenna (ΔZ).

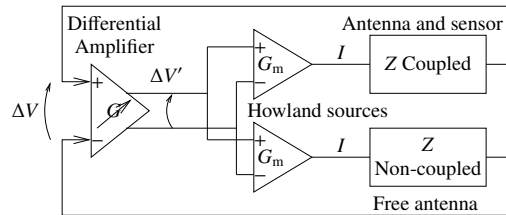

Fig. 4. Conditioning circuit overview showing the differential architecture.

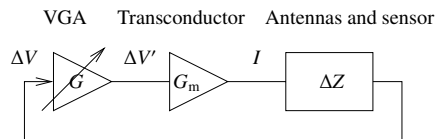

Fig. 5. Single-input, single-output equivalent model of the system.

It is absolutely similar to the one of an instrumentation amplifier. A variable resistor is used to adjust the gain G of this stage.

Each of the two other op-amps is connected as a Howland current source [5]. Both have differential inputs and generate a current I proportional to $\Delta V'$. Howland sources characteristics degrades with resistance variability. Thus, we use network of matched resistors. Moreover, this guarantees a good matching of the currents in the two antennas.

The circuit as been connected to two antennas, among which only one is inductively coupled with the IOP sensor (fig. 1). Each antenna is made of three turns of PCB track. After tuning the gain, oscillations can be observed on $\Delta V'$ (fig. 7). It is easy to read the frequency of 27.527 MHz corresponding to the sensor resonance. The non-harmonic aspect of the curve is due to the asymmetric saturation of the Howland sources.

3. Discussion and conclusion

The frequency of the oscillations is then constrained to the resonant frequency of the sensor. Thus, getting the patient's IOP is as simple as measuring the voltage frequency. Obviously, a fully functional system would embed frequency measure and automatic gain control.

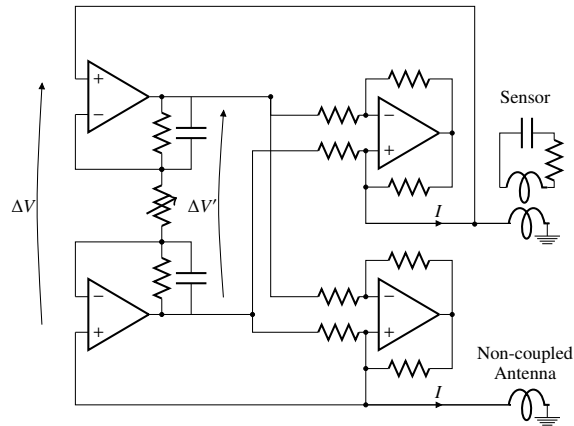

Fig. 6. Schematics of the conditioning circuit.



Fig. 7. Measured $\Delta V'$ voltage oscillations from the conditioner prototype.

This analog approach of conditioning minimizes the time and power consumption in comparison to a solution based, for example, on the response to a swept sine excitation, or on a PLL. Contrarily, our system does not require any sine generator. Moreover, the differential design makes it more robust against EM perturbations since the two antennas are expected to be placed in the same way on the glasses.

Eventually, this approach can be extended to other wireless resonant sensors. In the case where even lower consumption or higher frequency would be needed, the principle can be easily adapted to ASIC design instead of discrete components.

References

- [1] A. V. Mantravadi, N. Vadhar, Glaucoma, *Primary Care Ophthalmology* 42 (2015) 437–449.
- [2] C. Noël, A. M. Kabo, J. P. Romanet, A. Montmayeur, A. Buguet, Twenty-four-hour time course of intraocular pressure in healthy and glaucomatous africans: relation to sleep patterns, *Ophthalmology* 108 (2001) 139–144.
- [3] M. Leonardi, P. Leuenberger, D. Bertrand, A. Bertsch, P. Renaud, First steps toward noninvasive intraocular pressure monitoring with a sensing contact lens, *Investigative Ophthalmology & Visual Science* 45 (2004) 3113–3117.
- [4] P. Auvray, L. Rousseau, G. Lissorgues, F. Soulier, O. Potin, S. Bernard, F. Dieuleveult, E. Scorsone, P. Bergonzo, L. Chicaud, S. Picaud, J. Sahel, A passive pressure sensor for continuously measuring the intraocular pressure in glaucomatous patients, *IRBM* 33 (2012).
- [5] A Comprehensive Study of the Howland Current Pump, Texas Instrument, 2008. Application Report AN-1515.