



HAL
open science

On repetition thresholds of caterpillars and trees of bounded degree

Borut Lužar, Pascal Ochem, Alexandre Pinlou

► **To cite this version:**

Borut Lužar, Pascal Ochem, Alexandre Pinlou. On repetition thresholds of caterpillars and trees of bounded degree. *The Electronic Journal of Combinatorics*, 2018, 25 (1), pp.#P1.61. 10.37236/6793 . lirmm-01730276

HAL Id: lirmm-01730276

<https://hal-lirmm.ccsd.cnrs.fr/lirmm-01730276>

Submitted on 20 Dec 2019

HAL is a multi-disciplinary open access archive for the deposit and dissemination of scientific research documents, whether they are published or not. The documents may come from teaching and research institutions in France or abroad, or from public or private research centers.

L'archive ouverte pluridisciplinaire **HAL**, est destinée au dépôt et à la diffusion de documents scientifiques de niveau recherche, publiés ou non, émanant des établissements d'enseignement et de recherche français ou étrangers, des laboratoires publics ou privés.

On repetition thresholds of caterpillars and trees of bounded degree

Borut Lužar*, Pascal Ochem†, Alexandre Pinlou‡

September 11, 2018

Abstract

The *repetition threshold* is the smallest real number α such that there exists an infinite word over a k -letter alphabet that avoids repetition of exponent strictly greater than α . This notion can be generalized to graph classes. In this paper, we completely determine the repetition thresholds for caterpillars and caterpillars of maximum degree 3. Additionally, we present bounds for the repetition thresholds of trees with bounded maximum degrees.

Keywords: Infinite word; Repetition threshold; Graph coloring

1 Introduction

A word w of length $|w|=r$ over an alphabet \mathbb{A} is a sequence $w_1 \dots w_r$ of r letters, i.e. r elements of \mathbb{A} . A *prefix* of a word $w = w_1 \dots w_r$ is a word $p = w_1 \dots w_s$, for some $s \leq r$.

A *repetition* in a word w is a pair of words p (called the *period*) and e (called the *excess*) such that pe is a factor of w , p is non-empty, and e is a prefix of pe . The *exponent* of a repetition pe is $\exp(pe) = \frac{|pe|}{|p|}$. A β -*repetition* is a repetition of exponent β . A word is α^+ -*free* (resp. α -*free*) if it contains no β -repetition such that $\beta > \alpha$ (resp. $\beta \geq \alpha$).

Given $k \geq 2$, Dejean [7] defined the repetition threshold $\text{RT}(k)$ for k letters as the smallest α such that there exists an infinite α^+ -free word over a k -letter alphabet.

Dejean initiated the study of $\text{RT}(k)$ in 1972 for $k = 2$ and $k = 3$. Her work was followed by a series of papers which determine the exact value of $\text{RT}(k)$ for any $k \geq 2$.

Theorem 1 ([2, 4, 5, 6, 7, 9, 10, 12, 13]).

- (i) $\text{RT}(2) = 2$ [7];
- (ii) $\text{RT}(3) = \frac{7}{4}$ [7];
- (iii) $\text{RT}(4) = \frac{7}{5}$ [12];

*Faculty of Information Studies, Novo mesto, Slovenia. E-Mail: borut.luzar@gmail.com

†LIRMM, Université de Montpellier, Montpellier, France. E-Mail: pascal.ochem@lirmm.fr

‡LIRMM, Université Paul-Valéry Montpellier 3, Montpellier, France.

E-Mail: alexandre.pinlou@lirmm.fr

(iv) $\text{RT}(k) = \frac{k}{k-1}$, for $k \geq 5$ [2, 4, 5, 6, 9, 10, 12, 13].

The notions of α -free word and α^+ -free word have been generalized to graphs. A graph G is determined by a set of vertices $V(G)$ and a set of edges $E(G)$. A mapping $c : V(G) \rightarrow \{1, \dots, k\}$ is a k -coloring of G . A sequence of colors on a non-intersecting path in a k -colored graph G is called a *factor*. A coloring is said to be α^+ -free (resp. α -free) if every factor is α^+ -free (resp. α -free).

The notion of repetition threshold can be generalized to graphs as follows. Given a graph G and k colors,

$$\text{RT}(k, G) = \inf_{k\text{-coloring } c} \sup \{ \exp(w) \mid w \text{ is a factor in } c \} .$$

When considering the repetition threshold over a whole class of graphs \mathcal{G} , it is defined as

$$\text{RT}(k, \mathcal{G}) = \sup_{G \in \mathcal{G}} \text{RT}(k, G) .$$

In the remainder of this paper, \mathcal{P} , \mathcal{C} , \mathcal{S} , \mathcal{T} , \mathcal{T}_k , \mathcal{CP} , and \mathcal{CP}_k respectively denote the classes of paths, cycles, subdivisions¹, trees, trees of maximum degree k , caterpillars and caterpillars of maximum degree k .

Since α^+ -free words are closed under reversal, the repetition thresholds for paths are clearly defined as $\text{RT}(k, \mathcal{P}) = \text{RT}(k)$, and thus Theorem 1 completely determines $\text{RT}(k, \mathcal{P})$.

In 2004, Aberkane and Currie [1] initiated the study of the repetition threshold of cycles for 2 letters. Another result of Currie [3] on ternary circular square-free word allows to determine the repetition threshold of cycles for 3 letters. In 2012, Gorbunova [8] determined the repetition threshold of cycles for $k \geq 6$ letters.

Theorem 2 ([1, 3, 8]).

(i) $\text{RT}(2, \mathcal{C}) = \frac{5}{2}$ [1];

(ii) $\text{RT}(3, \mathcal{C}) = 2$ [3];

(iii) $\text{RT}(k, \mathcal{C}) = 1 + \frac{1}{\lceil k/2 \rceil}$, for $k \geq 6$ [8].

Gorbunova [8] also conjectured that $\text{RT}(4, \mathcal{C}) = \frac{3}{2}$ and $\text{RT}(4, \mathcal{C}) = \frac{4}{3}$.

For the classes of graph subdivisions and trees, the bounds are completely determined [11].

Theorem 3 ([11]).

(i) $\text{RT}(2, \mathcal{S}) = \frac{7}{3}$;

(ii) $\text{RT}(3, \mathcal{S}) = \frac{7}{4}$;

(iii) $\text{RT}(k, \mathcal{S}) = \frac{3}{2}$, for $k \geq 4$.

¹A subdivision of a graph G is a graph obtained from G by a sequence of edge subdivisions. Note that by a graph subdivision, a ‘‘large enough’’ subdivision is always meant.

Theorem 4 ([11]).

(i) $\text{RT}(2, \mathcal{T}) = \frac{7}{2}$;

(ii) $\text{RT}(3, \mathcal{T}) = 3$;

(iii) $\text{RT}(k, \mathcal{T}) = \frac{3}{2}$, for $k \geq 4$.

In this paper, we continue the study of repetition thresholds of trees under additional assumptions. In particular, we completely determine the repetition thresholds for caterpillars of maximum degree 3 (Theorems 5 to 7 and 11) and for caterpillars of unbounded maximum degree (Theorems 5 and 6) for every alphabet of size $k \geq 2$. We determine the repetition thresholds for trees of maximum degree 3 for every alphabet of size $k \in \{4, 5\}$ (Theorem 12). We finally give a lower and an upper bound on the repetition threshold for trees of maximum degree 3 for every alphabet of size $k \geq 6$ (Theorem 13). We summarize the results in Table 1 (shaded cells correspond to our results).

	$ \mathbb{A} = 2$	$ \mathbb{A} = 3$	$ \mathbb{A} = 4$	$ \mathbb{A} = 5$	$ \mathbb{A} = k, k \geq 6$
\mathcal{P}	2	$\frac{7}{4}$	$\frac{7}{5}$	$\frac{5}{4}$	$\frac{k}{k-1}$
\mathcal{C}	$\frac{5}{2}$	2	?	?	$1 + \frac{1}{\lceil k/2 \rceil}$
\mathcal{S}	$\frac{7}{3}$	$\frac{7}{4}$	$\frac{3}{2}$	$\frac{3}{2}$	$\frac{3}{2}$
\mathcal{CP}_3	3	2	$\frac{3}{2}$	$\frac{4}{3}$	$1 + \frac{1}{\lceil k/2 \rceil}$
\mathcal{T}_3	?	?	$\frac{3}{2}$	$\frac{3}{2}$	$1 + \frac{1}{2 \log k} + o\left(\frac{1}{\log k}\right)$
\mathcal{CP}	3	2	$\frac{3}{2}$	$\frac{3}{2}$	$\frac{3}{2}$
\mathcal{T}	$\frac{7}{2}$	3	$\frac{3}{2}$	$\frac{3}{2}$	$\frac{3}{2}$

Table 1: Summary of repetition thresholds for different classes of graphs.

2 Caterpillars

A *caterpillar* is a tree such that the graph induced by the vertices of degree at least 2 is a path, which is called *backbone*.

Theorem 5. $\text{RT}(2, \mathcal{CP}) = \text{RT}(2, \mathcal{CP}_3) = 3$.

Proof. First, we show that the repetition threshold is at least 3. Note that it suffices to prove it for the class of caterpillars with maximum degree 3. Suppose, to the contrary, that $\text{RT}(2, \mathcal{CP}_3) < 3$. Then, the factor xxx is forbidden for any $x \in \mathbb{A}$. Therefore, in any 3-free 2-coloring, every vertex colored with x has at most one neighbor colored with x . It follows that four consecutive backbone vertices of degree 3 cannot be colored $xyxy$ for any $x, y \in \mathbb{A}$, since the 3-repetition $xyxyxy$ appears. The factor xyx is also forbidden. Indeed, xyx must extend to $xyxyx$ on the backbone since $xyxy$ is forbidden. Then, $xyxyx$ must extend to $xyxyxyx$ on the backbone since xxx is forbidden. Finally, $xyxyxyx$ must extend to the 3-repetition $xyxyxyxyx$ in the caterpillar. Thus, the binary word on the backbone must avoid xxx and xyx . So, this word must be $(0011)^\omega$ which is not 3-free, a contradiction. Hence, $\text{RT}(2, \mathcal{CP}_3) \geq 3$.

Now, consider a 2-coloring of an arbitrary caterpillar such that the backbone induces a 2^+ -free word (which exists by Theorem 1(i)) and every pendent vertex gets the

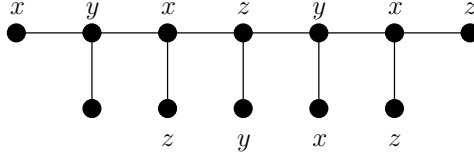

Figure 1: After a factor xyx , the remaining colors are forced.

color distinct from the color of its neighbor. Clearly, this 2-coloring is 3^+ -free, and so $\text{RT}(2, \mathcal{CP}) \leq 3$. \square

Theorem 6. $\text{RT}(3, \mathcal{CP}) = \text{RT}(3, \mathcal{CP}_3) = 2$.

Proof. We start by proving $\text{RT}(3, \mathcal{CP}_3) \geq 2$. So, suppose, for a contradiction, that there is a 2-free 3-coloring for any caterpillar with maximum degree 3. In every 2-free 3-coloring, the factor xyx appears on the backbone, since otherwise the word on the backbone would be $(012)^\omega$ which is not 2-free. Then, we have no choice to extend the factor xyx to the right (see Figure 1). This induces a 2-repetition $yxzyxz$.

Now, we show that $\text{RT}(3, \mathcal{CP}) \leq 2$ by constructing a 2^+ -free 3-coloring of an arbitrary caterpillar. Take a 2^+ -free 2-coloring of the backbone (which exists by Theorem 1), and color the pendent vertices with the third color. \square

Theorem 7. $\text{RT}(4, \mathcal{CP}_3) = \frac{3}{2}$.

Proof. By Theorem 4(iii), we have $\text{RT}(4, \mathcal{CP}_3) \leq \frac{3}{2}$. Let us show that any 4-coloring c of a caterpillar of maximum degree 3 contains a $\frac{3}{2}$ -repetition. Consider six consecutive vertices $u_0, u_1, u_2, u_3, u_4, u_5$ of the backbone. Let v_i be the pendent neighbors of u_i . In any $\frac{3}{2}$ -free coloring, the vertices u_1, u_2, u_3, v_2 must get distinct colors: say $c(u_1) = x, c(u_2) = y, c(u_3) = z, c(v_2) = t$. Either u_0 or u_4 must be colored with color t ; w.l.o.g. assume $c(u_4) = t$. Then, either u_5 or v_4 must be colored by y , and we obtain the $\frac{5}{3}$ -repetition $tyzty$. \square

Lemma 8. For every integer $k \geq 5$, we have $\text{RT}(k, \mathcal{CP}_3) \geq 1 + \frac{1}{\lceil k/2 \rceil}$.



(a) There exist 2η vertices at distance at most η from each other.

(b) Even case.

Figure 2: Illustrations of Lemma 8.

Proof. Let $\eta = \lceil \frac{k}{2} \rceil$. Suppose, to the contrary, that there exists a $(1 + \frac{1}{\eta})$ -free k -coloring c for any caterpillar with maximum degree 3. Then, every two vertices at distance at most η must be colored differently. In caterpillars with maximum degree 3, we can have 2η vertices being pairwise at distance at most η (see Figure 2a). If k is odd, then $2\eta > k$, and thus c is not $(1 + \frac{1}{\eta})$ -free. If k is even, the vertices x_i of Figure 2b necessarily get distinct colors, say x_i gets color i . Then, we have $c(y) \in \{1, 3\}$ and w.l.o.g. $c(y) = 1$. We also have $2 \in \{c(z_1), c(z_2)\}$ and w.l.o.g. $c(z_1) = 2$. Then we obtain a $(1 + \frac{2}{\eta+1})$ -repetition with excess $c(y)c(z_1) = 12$, a contradiction. \square

Lemma 9. $\text{RT}(5, \mathcal{CP}_3) \leq \frac{4}{3}$.

Proof. We start from a right infinite $\frac{5}{4}^+$ -free word $w = w_0w_1\dots$ on 5 letters. We associate to w its Pansiot code p such that $p_i = 0$ if $w_i = w_{i+4}$ and $p_i = 1$ otherwise, for every $i \geq 0$ [12]. Let us construct a $\frac{4}{3}^+$ -free 5-coloring c of the infinite caterpillar such that every vertex on the backbone has exactly one pendant vertex. For every $i \geq 0$, $c[0][i]$ is the color of the i -th backbone vertex and $c[1][i]$ is the color of the i -th pendant vertex.

We define below the mapping $h[t][\ell]$ such that $t \in \{0, 1\}$ corresponds to the type of transition in the Pansiot code and $\ell \in \{0, 1\}$ corresponds to the type of vertex ($\ell = 0$ for backbone, $\ell = 1$ for leaf):

$$\begin{aligned} h[0][0] &= 150251053150352053 \\ h[0][1] &= 033332322221211110 \\ h[1][0] &= 143123021324123103 \\ h[1][1] &= 000044440400004444 \end{aligned}$$

Notice that the length of $h[t][\ell]$ is 18. Given $t \in \{0, 1\}$ and $\ell \in \{0, 1\}$, let us denote $h[t][\ell][j]$, for $j \in \{0, \dots, 17\}$, the j^{th} letter of $h[t][\ell]$ (e.g. $h[0][0][3] = 2$).

The coloring is defined by $c[\ell][18i + j] = w_{i+h[p_i][\ell][j]}$ for every $\ell \in \{0, 1\}$, $i \geq 0$, and $j \in \{0, \dots, 17\}$. Let us prove that this coloring is $\frac{4}{3}^+$ -free.

We check exhaustively that there exists no forbidden repetition of length at most 576 in the caterpillar. Now suppose for contradiction that there exists a repetition r of length $n > 576$ and exponent $\frac{n}{d} > \frac{4}{3}$ in the caterpillar. This implies that there exists a repetition of length $n' \geq n - 2$ and period of length d in the backbone. This repetition contains a repetition r' consisting of full blocks of length 18 having length at least $n' - 2 \times (18 - 1) \geq n - 36$ and period length d . Given $n > 576$ and $\frac{n}{d} > \frac{4}{3}$, the repetition r' has exponent at least $\frac{n-36}{d} > \frac{5}{4}$.

The repetition r' in the backbone implies a repetition of exponent greater than $\frac{5}{4}$ in w , which is a contradiction. \square

Lemma 10. For every integer $k \geq 6$, we have $\text{RT}(k, \mathcal{CP}_3) \leq 1 + \frac{1}{\lceil k/2 \rceil}$.

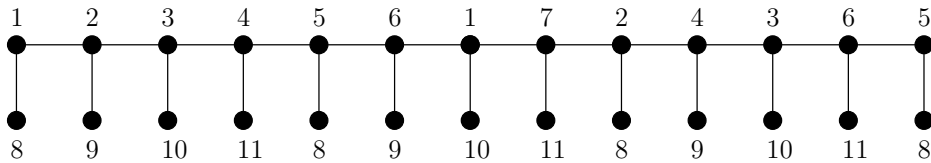

Figure 3: A $(1 + \frac{1}{6})^+$ -free 11-coloring of a caterpillar with maximum degree 3.

Proof. First notice that it suffices to construct colorings for odd k 's, since $1 + \frac{1}{\lceil k/2 \rceil} = 1 + \frac{1}{\lceil (k-1)/2 \rceil}$ for k even. So, let k be odd and let $\eta = \lceil \frac{k}{2} \rceil$.

By Theorem 1(iv), we can color the vertices of the backbone by a $(1 + \frac{1}{\eta})^+$ -free $(\eta + 1)$ -coloring. Then, it remains to color the pendant vertices: let us color them cyclically using the remaining $k - (\eta + 1) = \eta - 2$ unused colors (see Figure 3 for an example with $k = 11$). Clearly, the repetition which does contain a pendant vertex are $(1 + \frac{1}{\eta})^+$ -free. Moreover, for a repetition containing a pendant vertex, the length of the excess is at most 1 and the period length is at least η . Thus, its exponent is at most $\frac{\eta+1}{\eta} = 1 + \frac{1}{\eta}$.

This shows that this k -coloring is $(1 + \frac{1}{\eta})^+$ -free. \square

Lemmas 8 to 10 together imply the following theorem.

Theorem 11. For every integer k , with $k \geq 5$, we have $\text{RT}(k, \mathcal{CP}_3) = 1 + \frac{1}{\lceil k/2 \rceil}$.

Observe that for all $k \geq 4$, we have $\text{RT}(k, \mathcal{CP}) = \frac{3}{2}$. Indeed, caterpillars are trees and thus $\text{RT}(k, \mathcal{CP}) \leq \text{RT}(k, \mathcal{T}) = \frac{3}{2}$. On the other hand, we have $\text{RT}(k, \mathcal{CP}) \geq \text{RT}(k, K_{1,k}) = \frac{3}{2}$ (where $K_{1,k}$ is the star of degree k).

3 Trees of maximum degree 3

The class of trees of maximum degree 3 is denoted by \mathcal{T}_3 . Let $T \in \mathcal{T}_3$ be the infinite embedded rooted tree whose vertices have degree 3, except the root which has degree 2. Thus, every vertex of T has a left son and a right son. The *level* of a vertex of T is the distance to the root (the root has level 0).

Since every tree of maximum degree 3 is a subgraph of T , we only consider T while proving that $\text{RT}(k, \mathcal{T}_3) \leq \alpha$ for some k and α .

Note first that $\text{RT}(4, \mathcal{CP}_3) \leq \text{RT}(4, \mathcal{T}_3) \leq \text{RT}(4, \mathcal{T})$ and thus $\text{RT}(4, \mathcal{T}_3) = \frac{3}{2}$.

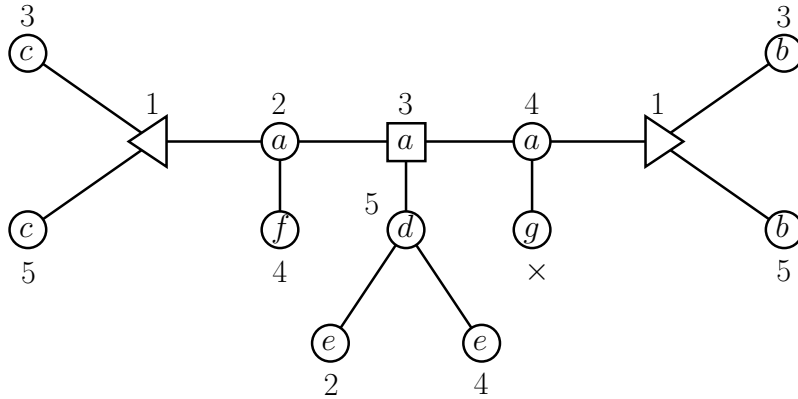

Figure 4: Construction for Theorem 12

Theorem 12. $\text{RT}(5, \mathcal{T}_3) = \frac{3}{2}$.

Proof. Note first that $\text{RT}(5, \mathcal{T}_3) \leq \text{RT}(5, \mathcal{T}) = \frac{3}{2}$. Let us show that this bound is best possible.

Let $G \in \mathcal{T}_3$ be the graph depicted in Figure 4 and let $v \in V(G)$ be the squared vertex. In every 5-coloring of G , at least two among the six vertices at distance 2 of v will get the same color. In every $\frac{3}{2}$ -free 5-coloring, the distance between these two vertices is four. W.l.o.g., the two triangle vertices of Figure 4 are colored with the same color, say color 1. Then, we color the other vertices following the labels in alphabetical order (a vertex labelled x is called an x -vertex). The a -vertices have to get three distinct colors (and distinct from 1), say 2, 3, and 4. The b -vertices can only get colors 3 or 5 and they must have distinct colors in every $\frac{3}{2}$ -free 5-coloring. This is the same for c -vertices. The d -vertex must then get color 5. Therefore the e -vertices can only get colors 2 or 4. The f -vertex must get color 4. Finally, the g -vertex cannot be colored without creating a forbidden factor. Thus $\text{RT}(5, \mathcal{T}_3) \geq \frac{3}{2}$, and that concludes the proof. \square

Theorem 13. *For every $t \geq 4$, we have*

$$\text{RT}((t+1)2^{\lfloor (t+1)/2 \rfloor}, \mathcal{T}_3) \leq 1 + \frac{1}{t} \leq \text{RT}(3(2^{\lfloor t/2 \rfloor} - 1), \mathcal{T}_3).$$

Proof. To prove that $\text{RT}((t+1)2^{\lfloor (t+1)/2 \rfloor}, \mathcal{T}_3) \leq 1 + \frac{1}{t}$, we color T as follows. Let f be the coloring of T mapping every vertex v to a color of the form (γ, λ) with $0 \leq \gamma \leq 2t+1$ and $\lambda \in \{0, 1\}^{\lfloor (t-1)/2 \rfloor}$. Let us describe each component of a color:

γ -component: Let us consider a Dejean word w over $t+1$ letters which is $(1 + \frac{1}{t})^+$ -free since $t \geq 4$. We apply to w the morphism m which doubles every letter, that is for every letter i such that $0 \leq i \leq t$, $m(i) = i_0 i_1$. Let $w' = m(w)$ and, given $\ell \geq 0$, let $w'[\ell]$ be the ℓ -th letter of w' . Every vertex at level ℓ gets $w'[\ell]$ as γ -component.

λ -component: Given a vertex v , let u be its ancestor at distance $\lfloor \frac{t-1}{2} \rfloor$ (or the root if v is at level $\ell < \lfloor \frac{t-1}{2} \rfloor$). Let $u = u_0, u_1, u_2, u_3, \dots, u_{\lfloor \frac{t-1}{2} \rfloor} = v$ be the path from u to v . The λ -component of v is the binary word built as follows: if u_{i+1} is the left son of u_i , then $\lambda[i] = 0$; otherwise, $\lambda[i] = 1$. If v is at level $\ell < \lfloor \frac{t-1}{2} \rfloor$, add $\lfloor \frac{t-1}{2} \rfloor - \ell$ 0's as prefix of λ .

Let us prove that f is a $(1 + \frac{1}{t})^+$ -free coloring.

Suppose that there exists a forbidden repetition such that the repeated factor is a single letter a , that is a factor axa where $|ax| < t$. Let u and v be the two vertices colored $f(u) = f(v) = (\gamma, \lambda)$. The vertices u and v must lie on the same level, since otherwise they would be at distance at least $2t$ due to γ . Since u and v are distinct and have the same λ , their common ancestor is at distance at least $\lfloor \frac{t-1}{2} \rfloor + 1$ from each of them. Thus u and v are at distance at least $2(\lfloor \frac{t-1}{2} \rfloor + 1) \geq t$, which contradicts $|ax| < t$.

Suppose now that there exists a forbidden repetition such that the length of the repeated factor is at least 2. Suppose first that the path supporting the repetition is of the form $l_i, l_{i-1}, l_{i-2}, \dots, l_1, l_0 = u = r_0, r_1, r_2, \dots, r_j$ where l_1 and r_1 are the left son and the right son of u , respectively. Let $l_i, l_{i-1}, \dots, l_1, l_0$ be the *left branch* and $r_0, r_1, \dots, r_{j-1}, r_j$ be the *right branch* of the path. W.l.o.g., assume that $1 \leq j \leq i$. Therefore, there exist two vertices l_k and l_{k-1} of the left branch such that $f(l_k l_{k-1}) = f(r_{j-1} r_j)$. Let us show that, given the γ -components of the colors of two adjacent vertices, it is possible to determine which vertex is the father. W.l.o.g. the two γ -components are i_0 and j_1 . If $i = j$, then the father is the vertex with γ -component i_0 ; otherwise, $i \neq j$ and the father is the vertex with γ -component j_1 . This is a contradiction since l_{k-1} is the father of l_k and r_{j-1} is the father of r_j . Suppose finally that the path supporting the repetition does not contain two brothers. This is equivalent to say that $m(w)$ is not $(1 + \frac{1}{t})^+$ -free. It is clear that if the m -image of a word contains an e -repetition, then this word necessarily contains an e -repetition. This implies that w is not $(1 + \frac{1}{t})^+$ -free, a contradiction.

Therefore, we have $\text{RT}((t+1)2^{\lfloor (t+1)/2 \rfloor}, \mathcal{T}_3) \leq 1 + \frac{1}{t}$.

To prove that $\text{RT}(3(2^{\lfloor t/2 \rfloor} - 1), \mathcal{T}_3) \geq 1 + \frac{1}{t}$, we consider the tree $T \in \mathcal{T}_3$ consisting of a vertex and all of its neighbors at distance at most $\lfloor t/2 \rfloor$. The distance between every two vertices in T is at most t . Thus, no two vertices of T have the same color in a $(1 + \frac{1}{t})$ -free coloring. Since T contains $3(2^{\lfloor t/2 \rfloor} - 1) + 1$ vertices, it admits no $(1 + \frac{1}{t})$ -free coloring with $3(2^{\lfloor t/2 \rfloor} - 1)$ colors, which gives $\text{RT}(3(2^{\lfloor t/2 \rfloor} - 1), \mathcal{T}_3) \geq 1 + \frac{1}{t}$. \square

Note that Theorem 13 can be generalized to trees of bounded maximum Δ . This would give the following:

$$\text{RT}(2(t+1)(\Delta-1)^{\lfloor (t-1)/2 \rfloor}, \mathcal{T}_\Delta) \leq 1 + \frac{1}{t} \leq \text{RT}\left(\frac{\Delta((\Delta-1)^{\lfloor t/2 \rfloor} - 1)}{\Delta-2}, \mathcal{T}_\Delta\right)$$

4 Conclusion

In this paper, we continued the study of repetition thresholds in colorings of various subclasses of trees. We completely determined the repetition thresholds for caterpillars and caterpillars of maximum degree 3, and presented some results for trees of maximum degree 3. There are several open questions in the latter class for which it appears that more advanced methods of analysis should be developed. In particular, our bounds show that

$$3 \leq \text{RT}(2, \mathcal{T}_3) \leq \frac{7}{2} \quad \text{and} \quad 2 \leq \text{RT}(3, \mathcal{T}_3) \leq 3,$$

however, we have not been able to determine the exact bounds yet. Additionally, the repetition thresholds in trees of bounded degrees for alphabets of size at least 6 remain unknown.

Acknowledgement. The research was partially supported by Slovenian research agency ARRS program no. P1-0383 and project no. L1-4292 and by French research agency ANR project COCOGRO.

References

- [1] A. Aberkane and J. D. Currie. There exist binary circular $5/2^+$ power free words of every length. *Electron. J. Combin.*, 11:#R10, 2004.
- [2] A. Carpi. On Dejean's conjecture over large alphabets. *Theoret. Comput. Sci.*, 385(1-3):137-151, 2007.
- [3] J. D. Currie. There are ternary circular square-free words of length n for $n \geq 18$. *Electron. J. Combin.*, 9:1-7, 2002.
- [4] J. D. Currie and N. Rampersad. Dejean's conjecture holds for $n \geq 27$. *RAIRO - Theoretical Informatics and Applications*, 43(4):775-778, 2009.
- [5] J. D. Currie and N. Rampersad. Dejean's conjecture holds for $n \geq 30$. *Theoret. Comput. Sci.*, 410(30-32):2885-2888, 2009.
- [6] J. D. Currie and N. Rampersad. A proof of Dejean's conjecture. *Math. Comp.*, 80:1063-1070, 2011.
- [7] F. Dejean. Sur un théorème de Thue. *J. Combin. Theory Ser. A*, 13:90-99, 1972.
- [8] I. A. Gorbunova. Repetition threshold for circular words. *Electron. J. Combin.*, 19(4):P11, 2012.
- [9] M. Mohammad-Noori and J. D. Currie. Dejean's conjecture and Sturmian words. *Europ. J. Combin.*, 28(3):876-890, 2007.

- [10] J. Moulin Ollagnier. Proof of Dejean's conjecture for alphabets with 5, 6, 7, 8, 9, 10 and 11 letters. *Theoret. Comput. Sci.*, 95(2):187–205, 1992.
- [11] P. Ochem and E. Vaslet. Repetition thresholds for subdivided graphs and trees. *RAIRO - Theoretical Informatics and Applications*, 46(1):123–130, 2012.
- [12] J.-J. Pansiot. A propos d'une conjecture de F. Dejean sur les répétitions dans les mots. *Discrete Appl. Math.*, 7(3):297–311, 1984.
- [13] M. Rao. Last cases of Dejean's conjecture. *Theoret. Comput. Sci.*, 412(27):3010–3018, 2011.