



HAL
open science

Frequency Injection Locking-Controlled Oscillations for Synchronized Operations in VO₂ Crossbar Devices

Elisabetta Corti, Corentin Delacour, Aida Todri-Sanial, Siegfried Karg

► **To cite this version:**

Elisabetta Corti, Corentin Delacour, Aida Todri-Sanial, Siegfried Karg. Frequency Injection Locking-Controlled Oscillations for Synchronized Operations in VO₂ Crossbar Devices. DRC 2021 - 79th Device Research Conference, Jun 2021, Santa Barbara (Virtual), United States. pp.1-2, 10.1109/DRC52342.2021.9467129 . lirmm-03197330

HAL Id: lirmm-03197330

<https://hal-lirmm.ccsd.cnrs.fr/lirmm-03197330>

Submitted on 11 Nov 2021

HAL is a multi-disciplinary open access archive for the deposit and dissemination of scientific research documents, whether they are published or not. The documents may come from teaching and research institutions in France or abroad, or from public or private research centers.

L'archive ouverte pluridisciplinaire **HAL**, est destinée au dépôt et à la diffusion de documents scientifiques de niveau recherche, publiés ou non, émanant des établissements d'enseignement et de recherche français ou étrangers, des laboratoires publics ou privés.

Frequency Injection Locking-Controlled Oscillations for Synchronized Operations in VO₂ Crossbar Devices

Elisabetta Corti^{1*}, Corentin Delacour^{2*}, Aida Todri-Saniai² and Siegfried Karg¹

*contributed equally

¹IBM Research Zurich, Säumerstrasse 4, 8803 Rüschlikon, Switzerland

²LIRMM CNRS, 161, rue Ada, 34095 Montpellier, France

Email: corentin.delacour@lirmm.fr / Phone: +33 (0) 4 67 14 97 44

Introduction

Compact oscillating devices can be realized by exploiting the insulator-to-metal transition of VO₂ (IMT). Coupled oscillators can be locked in frequency and phase through connections realized with resistors or capacitors. Oscillatory neural networks based on VO₂ devices are researched as neuromorphic computing hardware for image recognition applications [1,2]. Physical demonstrations of large networks of coupled oscillators are yet hindered by the device-to-device variability [3]. In this work, we present a frequency-injection scheme which allows additional tuning and control of the oscillator network comprising non-ideal VO₂ devices.

Results

The VO₂ devices are realized in a crossbar (CB) geometry on a Si/SiO₂ substrate using a CMOS compatible process. Planarized bottom contacts have been fabricated with ebeam-lithography and lift-off. Consequently, a VO₂ film is prepared with atom layer deposition and post-anneal. Finally, with a last lithography step the top contact is defined (Fig.1). Due to the polycrystalline nature of the VO₂ layer, some device-to-device variability occurs. The current-voltage (IV) characteristics of the device is measured with a current source in a temperature-controlled environment and exhibits an IMT transition which a negative differential resistance (NDR) behavior (Fig.2). Relaxation oscillators were formed biasing the VO₂ device in the NDR region using a series transistor as load (Fig.3). It has been shown in literature that the greatest limitation in experimentally achieving large systems of coupled oscillators is indeed the device-to-device mismatch, which causes the natural frequency of the oscillators to diverge and therefore doesn't allow for the devices to lock in frequency [3]. The harmonic injection (HI) approach achieves tuning of the output oscillating frequency through the injection of an AC signal superimposed to the gate voltage of the biasing transistor. The spontaneous oscillations of a VO₂ device measured at the drain of the transistor is shown in Fig. 4 a together with the applied gate voltage (V_{G1} kept at 1.1 V). The VO₂ device presents spontaneous oscillations at 4.7 kHz (Fig. 4 b). When V_{G1} is modulated with a 200 mV peak-to-peak harmonic injection (HI) AC signal at 5 kHz, the VO₂ device locks in frequency with the input AC signal (Fig. 4 c and d). Systematic experiments show that the VO₂ oscillator output frequency locks with the AC input for a wide range of frequencies, down to 3.5 kHz and up to 6 kHz. Outside these values the synchronization is lost (Fig. 5). Therefore, the HI technique enables to tune the oscillation frequency of the single oscillators and to promote coupling of devices which present device-to-device variability. This is demonstrated experimentally in Fig. 6, where two VO₂ oscillators with the same dimensions present different oscillating threshold voltages. Through the coupling with a resistor and the HI in the gate voltages, the oscillators are coupled in frequency and achieve in-phase and out-of-phase synchronization.

We assess the impact of device-to-device variability on oscillator frequency by performing circuit-level simulations of two coupled VO₂ devices. At circuit-level, we emulate the oscillator's frequency mismatch by varying the load capacitor C_p from 0.8 to 1.2 nF to obtain variations with respect to the nominal case at 300 kHz. Then, we simulate two mismatched VO₂-oscillators coupled by a 6 k Ω -resistor, using the VO₂ compact model from [4] to determine the synchronization region (Fig. 7) for two different configurations: 1) without harmonic injection and 2) with harmonic injection where we apply the same 200 mVpp sinusoidal gate voltage at 300 kHz. In the first configuration, up to 5% of frequency deviation is tolerated when one oscillator switches at the nominal frequency, whereas up to 18% frequency mismatch is tolerated using the frequency injection technique. Overall the synchronization region is enlarged, making the frequency injection attractive for oscillatory neural networks design where information is contained in the phase between frequency-locked oscillators.

We would like to acknowledge the founding of the HORIZON 2020 NEURONN project (Grant no. 871501).

[1] G. Csaba and W. Porod, Appl. Phys. Rev. 7, 2020

[2] Corti et al., Front. in Neurosc. 15, 2021

[3] Corti et al., Solid State Elect. 168, 2020

[4] P. Maffezzoni et al., IEEE Trans. on Cir. and Syst. I, 62, 2015

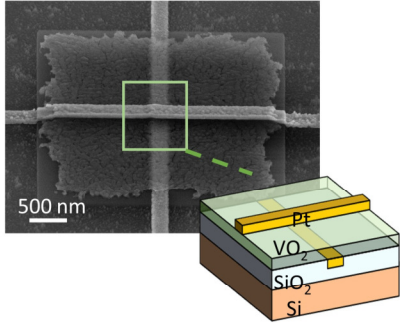

Fig.1: Scanning Electron Microscope picture of a crossbar device and corresponding device schematic.

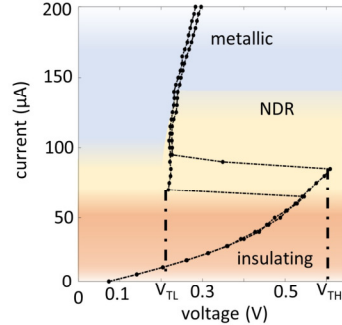

Fig.2: IV characteristic of a VO₂ CB device. The insulating, metallic and NDR regime are highlighted.

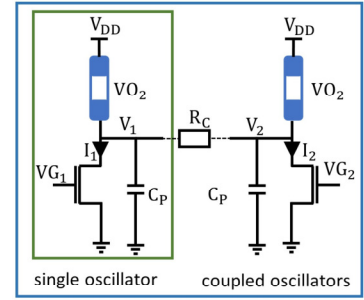

Fig.3: Electrical connections for a single and coupled oscillator experiment.

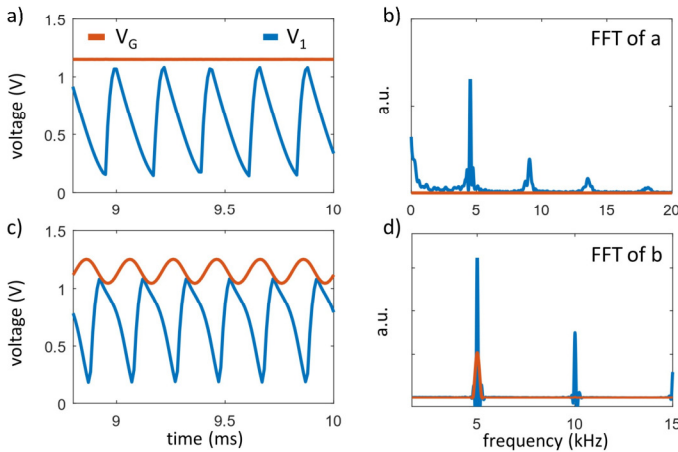

Fig.4: Experimental curves of a single VO₂ oscillator. a) and b) oscillations and corresponding fast Fourier transform (FFT) with a constant gate voltage. c) and d) superimposing an AC signal at the gate voltage, the VO₂ oscillator output signal locks to the AC input frequency, allowing for frequency tuning.

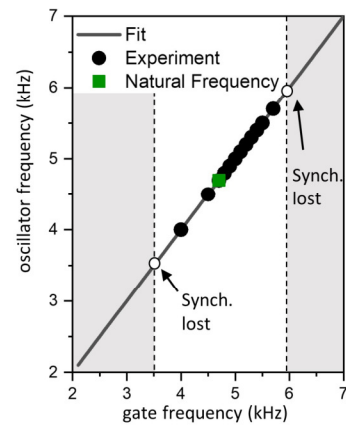

Fig.5: experimental results of frequency injection locking. Changing the frequency of the gate signal, we can tune the oscillator frequency. For $|f_g - f_n| > 25\% f_n$, the VO₂ oscillator cannot follow anymore the input gate voltage and synchronization is lost.

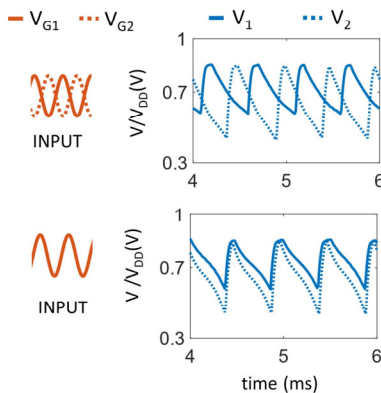

Fig.6: Experimental curves of two oscillator with variable threshold voltage values (V_{TH} and V_{TL}) locked in frequency thanks to the HI synchronization scheme. The relative phase of the oscillators can be controlled through the phase of the AC input.

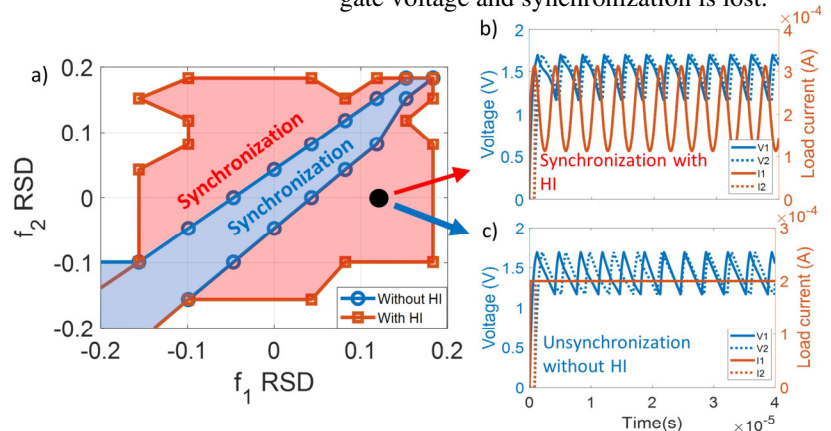

Fig.7: a) Simulations shows the synchronization space of two resistively-coupled VO₂ oscillators with different natural frequencies. Without the HI technique, the synchronization space is limited, with the HI technique synchronization is achieved for diverging natural frequencies up to 18% Relative Standard Deviation (RSD). b) and c) examples of oscillator output with and without HI.