



**HAL**  
open science

## Exploration of a digital-based solution for the generation of 2.4GHz OQPSK test stimuli

Thibault Vayssade, Mouhamad Chehaitly, Florence Azaïs, Laurent Latorre,  
François Lefèvre

### ► To cite this version:

Thibault Vayssade, Mouhamad Chehaitly, Florence Azaïs, Laurent Latorre, François Lefèvre.  
Exploration of a digital-based solution for the generation of 2.4GHz OQPSK test stimuli.  
ETS 2021 - 26th IEEE European Test Symposium, May 2021, Bruges, Belgium. pp.1-6,  
10.1109/ETS50041.2021.9465473 . lirmm-03426321

**HAL Id: lirmm-03426321**

**<https://hal-lirmm.ccsd.cnrs.fr/lirmm-03426321>**

Submitted on 12 Nov 2021

**HAL** is a multi-disciplinary open access archive for the deposit and dissemination of scientific research documents, whether they are published or not. The documents may come from teaching and research institutions in France or abroad, or from public or private research centers.

L'archive ouverte pluridisciplinaire **HAL**, est destinée au dépôt et à la diffusion de documents scientifiques de niveau recherche, publiés ou non, émanant des établissements d'enseignement et de recherche français ou étrangers, des laboratoires publics ou privés.

# Exploration of a digital-based solution for the generation of 2.4GHz OQPSK test stimuli

Thibault VAYSSADE  
Univ. Montpellier, CNRS, LIRMM  
Montpellier, France

Mouhamad CHEHAITLY  
Univ. Montpellier, CNRS, LIRMM  
Montpellier, France

Florence AZAIS  
Univ. Montpellier, CNRS, LIRMM  
Montpellier, France

Laurent LATORRE  
Univ. Montpellier, CNRS, LIRMM  
Montpellier, France

François LEFEVRE  
NXP Semiconductors  
Caen, France

**Abstract**— In this paper, we explore a digital-based solution for the generation of 2.4GHz OSQSK test stimuli. The objective is to reduce the testing costs of ZigBee receivers by enabling their test on a standard digital Automatic Test Equipment (ATE). The proposed strategy relies on the generation of a modulated square wave signal in the intermediate frequency band using a digital tester channel, and the filtering of one of its harmonics to produce the RF signal. Appropriate modulation format has to be encoded in the square-wave signal so that the typical characteristics of a ZigBee signal are present in the chosen harmonic component. A dedicated pre-processing algorithm has been developed to determine this encoding. The proposed strategy is then evaluated through Matlab simulations, taking into account the practical constraints imposed by a standard digital ATE.

**Keywords**— RF signal generation; digital ATE; signal processing, ZigBee; OQPSK

## I. INTRODUCTION

The conventional solution for testing RF devices relies on the use of an ATE equipment with RF resources in order to generate/analyze RF signals. This solution offers good test quality but suffers from high cost due to the price of RF tester channels, which are extremely expensive compared to their digital counterpart. The reduction of RF testing costs is today a major concern for most of the semiconductor manufacturing companies, especially with respect to the very competitive market of the Internet-of-Things (IoT).

An interesting approach is to develop digital solutions, as preconized by the ITRS. A number of works can be found in the literature, e.g. based on the use of a reference transceiver accompanied by a FPGA to handle the interface between the transceiver and a digital ATE [1], or based on the use of a processor embedded in a radio SoC to implement self-test and provide low-frequency digital output [2], or defining a digital ATE system with multi-level drivers and comparators for direct modulation/demodulation of QAM signals [3]. More recently, a solution based on direct 1-bit under-sampled acquisition has been proposed that permits the test of ZigBee transmitters on a standard digital ATE [4,5].

In this work, our objective is to explore a digital solution for the generation of a 2.4GHz OSQPSK test stimulus in order to enable the test of ZigBee receivers on a standard digital ATE. Note that some works exist in the literature dealing with the generation of analog test stimuli from digital resources [6-8], but not applicable to test stimulus generation in the RF frequency range. An original approach for the excitation of RF devices is suggested in [9,10], which consists in using the

harmonic tones of a pulse sequence. We intend to exploit this principle in order to generate a ZigBee test stimulus.

## II. BACKGROUND

### A. ZigBee Signal Characteristics

This section briefly summarizes the main characteristics of the signal to be generated, which are specified by the IEEE Std 802.15.4™. In this work, we focus on the 2.4GHz band, which is an ISM band accepted worldwide.

The modulation format is Offset Quadrature Phase Shift Keying (OQPSK) with half-sine pulse shaping. OQPSK is a variant of QPSK where an offset of one-bit period (half-symbol period) is added on the signal in the Q branch in order to ensure that signals in the I and Q branches never change at the same time, which limits the phase jump to 90° and reduces amplitude variations. Moreover, half sine pulse shaping is applied in each branch after the classical NRZ encoding to smooth the phase transitions and ensure a constant modulation envelope. These two features permit to obtain a better spectral efficiency than the classical QPSK modulation format. Finally, another feature specified by the standard is the use of Direct Sequence Spread Spectrum (DSSS) technique in order to reduce the overall signal interference. As a consequence, the chip rate is much higher than the input data rate, i.e. 2Mchip/s at the input of the modulator while only 250kb/s for the input data rate.

### B. Current test solution for RF receivers

The current industrial practice for production testing of RF receivers relies on the use of an ATE equipped with RF tester channels that generate the test stimulus. As illustrated in Figure 1, such channels comprise specific hardware resources (DACs, filters, mixers, ...) that implement a baseband generator and an IQ modulator. The baseband generator provides the modulating signals from the binary data stored in the ATE memory. These signals are then multiplied in the IQ modulator by a high frequency carrier and added to form the RF signal.

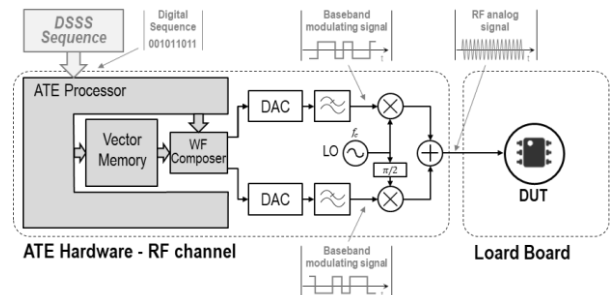

Fig. 1. Current industrial solution for generation of the test stimulus

The main drawback of this solution is its cost. Indeed, because of the required hardware resources with very exigent performances, the cost of a RF tester channel is extremely high and constitutes a major contributor to RF testing costs.

### III. PROPOSED STRATEGY

#### A. Principle

Our strategy to reduce RF testing costs is to propose new solutions that can be applied using standard digital tester channels instead of RF instrumentation. The targeted solution for the generation of the test stimulus is illustrated in Figure 2. The basic principle is to use the standard resources of a digital ATE channel for the generation of a modulated square-wave signal. For this, the digital sequence stored in the ATE memory is simply read and formatted according to programmed voltage and timing setups to produce the electrical signal delivered by the tester channel driver. However, the frequency of the generated signal is obviously limited by the maximum value of the ATE operating frequency, which determines the reading rate of the digital data stored in the memory. For a standard ATE, the maximum operating frequency is typically 1.6Gs/s, which means that the generation of a simple square-wave is limited to 800MHz, and even less in case of a modulated square-wave. This is obviously not sufficient in the context of our objective, i.e. the test of ZigBee receivers operating around 2.4GHz.

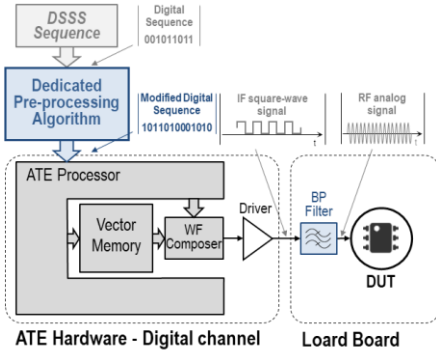

Fig. 2. Targeted solution for generation of the test stimulus

To cope with this issue, our idea is to exploit harmonic filtering. Indeed, a square-wave signal exhibits harmonic components located at odd multiples of the signal frequency. Our proposal is to use a filter centered on one of these harmonic components in order to obtain a signal in the RF band from the square-wave signal generated in the IF band. This filter can be placed on the load board that realizes the interface between the ATE and the Device Under Test (DUT).

Then the second challenge is how to define the appropriated modulation of the base square-wave signal generated by the ATE such that the filtered signal exhibits the same characteristics as a ZigBee signal. For this, the main assumption is that the replicas around each harmonic contain an image of the base signal but with a modified phase modulation index  $\beta_i = i * \beta_1$ , where  $i$  is the order of the harmonic component and  $\beta_1$  is the phase modulation index of the square signal generated by the ATE (this assumption can be easily demonstrated based on Fourier expansion).

In this context, the first requirement for the generation of the base square-wave signal is that its fundamental frequency should be an odd submultiple of the RF signal carrier frequency:

$$f_{square} = \frac{f_c}{N} \text{ with } N \text{ belonging to } \{3, 5, 7, \dots\} \quad (1)$$

where  $f_c$  is the carrier frequency of the RF signal and  $N$  is the selected harmonic component that will be filtered to generate the RF signal.

The second requirement is that its modulation index used to encode the base square-wave signal should be equal to the modulation index of the targeted RF signal divided by the selected harmonic component:

$$\beta_{square} = \frac{\beta}{N} \quad (2)$$

where  $\beta$  is the modulation index of the targeted RF signal.

To summarize, the proposed strategy relies on (i) the generation of a modulated square-wave signal in the IF band using a standard digital tester channel, and (ii) the filtering of one of its harmonic component in order to obtain a signal in the RF band. According to the targeted RF signal, the modulated square-wave signal should be generated with a downscaling factor of  $1/N$  on both its fundamental frequency and modulation index. This principle is illustrated in Figure 3 for  $N = 5$  and  $f_c = 2.405GHz$ .

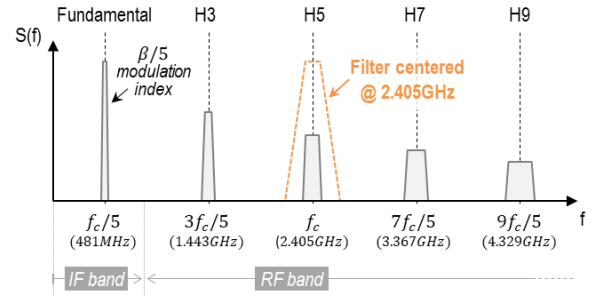

Fig. 3. Principle of the proposed strategy with  $N = 5$

An essential element of this strategy is the pre-processing algorithm that permits to transform the input DSSS sequence into a modified digital sequence stored in the ATE, which will encode the appropriate modulation in the base square-wave signal. This algorithm is detailed in the following section.

#### B. Pre-processing algorithm

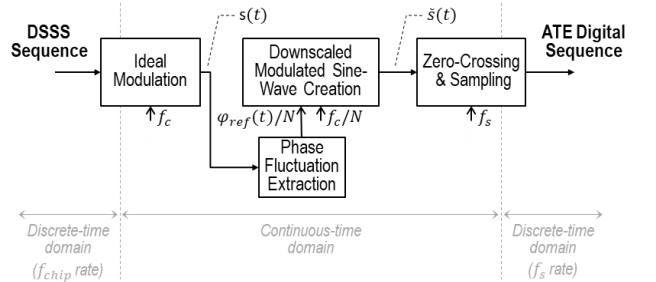

Fig. 4. Block diagram of the pre-processing algorithm

The software algorithm that generates the ATE digital sequence from the input DSSS sequence has been developed in the Matlab® environment. The principle is (i) to generate an ideal modulated RF signal corresponding to the input DSSS sequence, (ii) transform this signal into a downscaled version and, (iii) convert the downscaled version into a square-wave signal sampled at the ATE operating frequency. The block diagram of the processing algorithm is given in Figure 4 and the different steps are detailed hereafter.

The first step is to generate the ideal modulated RF signal  $s(t)$  corresponding to the DSSS sequence. For this, the DSSS sequence is applied at the input of an ideal OQPSK modulator with half-sine pulse shaping. The block diagram of this ideal modulator is illustrated in Figure 5. The binary data stream is first split into two branches. Even bits are fed in the in-phase branch ( $I$  branch) and odd bits in the quadrature-phase branch ( $Q$  branch). A bipolar NRZ coding is then applied on each branch, followed by half-sine pulse shaping. A delay of one-bit period is added on the signal in the  $Q$  branch. The in-phase and quadrature-phase components are then modulated onto two orthogonal basis functions and finally summed to form the RF signal. Note that in this model, interpolation is included after the serial-to-parallel conversion in order to obtain a pseudo continuous-time representation of the signals in the  $I$  and  $Q$  branches, where each bit has a duration of  $2T_{chip}$ .

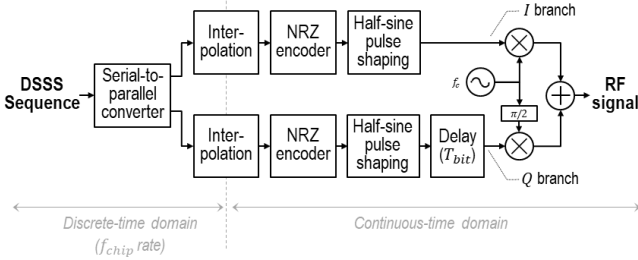

Fig. 5. Block diagram of ideal OQPSK modulator with half-sine pulse shaping

The second step is to create a downsampled version  $\tilde{s}(t)$  of the ideal modulated RF signal  $s(t)$ . For this, the instantaneous phase of the RF signal  $\Phi_i(t)$  is first extracted using the Hilbert transform:

$$\Phi_i(t) = \text{atan} \left( \frac{HT[s(t)]}{s(t)} \right) \quad (3)$$

Due to the  $\text{atan}$  function, the computed instantaneous phase is a wrapped phase. By unwrapping  $\Phi_i(t)$ , we obtain a linear evolution of the instantaneous phase  $\Phi_u(t)$ , which can be expressed as:

$$\Phi_u(t) = 2\pi f_c t + \varphi_{ref}(t) \quad (4)$$

where the first term corresponds to the linear phase of a signal with a carrier frequency  $f_c$  and the second term corresponds to the phase fluctuation  $\varphi_{ref}(t)$  of the ideal modulated RF signal.

By subtracting the linear term, we obtain the phase fluctuation  $\varphi_{ref}(t)$  of the ideal modulated RF signal:

$$\varphi_{ref}(t) = \Phi_u(t) - 2\pi f_c t \quad (5)$$

Finally, to create the downsampled version  $\tilde{s}(t)$  of the ideal modulated RF signal, we just have to insert the phase fluctuation divided by  $N$  within a sine-wave with a frequency at  $f_c/N$ :

$$\tilde{s}(t) = \sin \left( 2\pi \frac{f_c}{N} t + \frac{\varphi_{ref}(t)}{N} \right) \quad (6)$$

The last step of the pre-processing algorithm is to convert this downsampled signal into a square-wave signal and determine the binary value present in this signal at each  $T_s = 1/f_s$  instant, where  $f_s$  is the ATE operating frequency. This is accomplished by a zero-crossing operation associated with sampling. The output of this step is a digital sequence defined at  $f_s$  rate, and corresponds to the digital sequence that has to be stored in the tester memory.

It is important to highlight that, because of this sampling process, there is a discretization of the phase fluctuation encoded in the square-wave that will be delivered by the ATE. This creates additional frequency components that are susceptible to modify the expected spectrum of the modulated square-wave and therefore modify the characteristics of the signal filtered around the 5<sup>th</sup> harmonic. The objective of this study is to explore by simulation whether we can identify one or several ATE operating frequencies that permits, despite this phenomenon, to preserve the characteristics of a ZigBee signal around one of its harmonics.

### C. Constraints for practical implementation on digital ATE

The proposed strategy relies on the generation of a modulated square-wave signal with a fundamental frequency at  $f_c/N$ . A primary requirement is therefore that this fundamental frequency is compatible with the maximum ATE operating frequency  $f_{smax}$ :

$$f_c/N < f_{smax}/2 \quad (7)$$

In our context, we target the generation of a modulated RF signal at  $f_c = 2.405GHz$ . Considering the typical value of  $f_{smax} = 1.6Gs/s$  for a standard digital ATE, the smallest integer that permits to satisfy the requirement of Eq.(7) is  $N = 5$ . This is the choice used in this work (fundamental frequency of the modulated square-wave signal fixed at 481MHz).

Then, the first constraint on the setting of the ATE operating frequency is related to the Nyquist criterion, i.e. the ATE frequency should be set at least at twice the fundamental frequency of the base modulated signal ( $f_s > 962MHz$ ).

The second constraint is related to the timing resolution of the ATE. Indeed, the setting of the operating frequency is usually done by the definition of a cycle duration, also called tester period. On the targeted equipment (PS1600 on Advantest 93k), a cycle can contain up to 8 edges, each one associated either to a read or write event. The minimum cycle duration is 5ns, which corresponds to a maximum generation rate of 1.6GS/s (8 edges associated with a write event and uniformly spread over one tester period). However, the setting of the cycle duration can be done only with a fixed resolution of 0.1ns, which means that the operating frequency can take only a certain number of discrete values. In our case, to satisfy the constraint  $f_s > 962MHz$ , we have 34 possible values for the tester period, ranging from the minimum cycle duration of 5ns ( $f_s = 1.6GHz$ ) up to 8.3ns ( $f_s = 963.9MHz$ ).

Finally, the last element to be specified is the analog bandpass filter that will be placed on the load board. This filter must be centered on the carrier frequency of the RF signal, i.e. around 2.4GHz, and have a bandwidth at least equal to the bandwidth of a ZigBee signal, i.e. 5MHz. Obviously, the quality of the generated signal will be affected by the filter bandwidth. Indeed, we expect that the smaller this bandwidth, the better the filtering of unwanted components and the better the quality of the generated signal. However, in this frequency range, the design of a filter with such a narrow bandwidth is quite challenging. Off-the-shelf components (SAW filters) today commercially available in this frequency range actually present a bandwidth in the order of few tens of MHz. Therefore, in this study, we will investigate the use of a filter with a bandwidth from 10MHz up to 80MHz.

#### IV. SIMULATION SETUP

An experimental simulation setup has been developed in the Matlab® environment to explore the proposed strategy. This setup, illustrated in Figure 6, comprises a first part dedicated to the generation of the modulated RF signal and a second one dedicated to the analysis of this signal. Details on the two parts are given in the following sections.

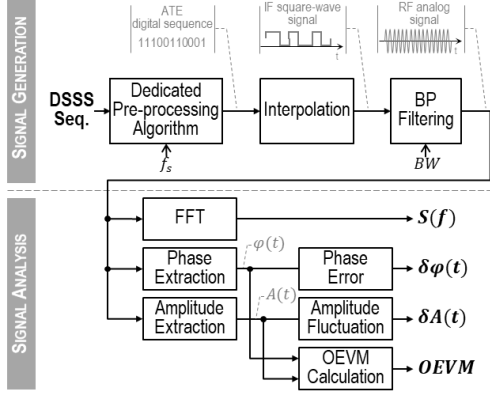

Fig. 6. Simulation setup

##### A. Signal generation

The first part of the simulation setup is dedicated to the generation of the modulated RF signal using a digital tester channel. It takes as inputs the DSSS sequence, the ATE operating frequency and the filter bandwidth.

In a first step, the dedicated pre-processing algorithm is applied to the input DSSS sequence to produce the digital sequence that will be stored in the tester memory, for a given ATE frequency  $f_s$ . A representation of the electrical square-wave signal that will be delivered on the output of the digital tester channel is then obtained by converting the digital sequence into the continuous-time domain using interpolation. Finally, bandpass filtering is applied on this waveform to generate the RF modulated signal. In this work, we use a software digital 4<sup>th</sup> order Butterworth filter with a bandwidth defined by  $BW$ , and we implement a zero-phase filter using the forward-backward filtering technique.

##### B. Signal analysis

The second part of the simulation setup is dedicated to signal analysis. It takes as input the filtered signal obtained from the square-wave signal generated by the digital tester channel. Various computations are then applied on this signal to evaluate its quality.

First, FFT computation is applied to obtain the spectrum  $S(f)$  of the generated signal. This spectrum will be compared to the spectrum of an ideal modulated RF signal.

Then, the Hilbert Transform is used to extract the phase fluctuation  $\varphi(t)$  of the generated signal (same procedure than the one used in section III.B to extract the phase fluctuation of the ideal modulated RF signal). The phase error between the generated signal and the ideal one is computed with:

$$\delta\varphi(t) = \varphi(t) - \varphi_{ref}(t) \quad (8)$$

The Hilbert Transform is also used to extract the envelope  $A(t)$  of the generated signal:

$$A(t) = \sqrt{s(t)^2 + HT[s(t)]^2} \quad (9)$$

Although the ideal modulated RF signal has a constant amplitude, it is likely that the envelope of the generated signal exhibits some fluctuations, which are computed with:

$$\delta A(t) = A(t) - A_{mean} \quad (10)$$

To quantify the magnitude of the phase error and of the amplitude fluctuation, we will use the Normalized Root Mean Square (NRMS), which is respectively computed by:

$$NRMS-\delta\varphi = \frac{\sqrt{\frac{1}{n} \sum_{i=1}^n (\delta\varphi(t_i))^2}}{2\pi} * 100 \quad (11)$$

$$NRMS-\delta A = \frac{\sqrt{\frac{1}{n} \sum_{i=1}^n (\delta A(t_i))^2}}{A_{max}} * 100 \quad (12)$$

Finally, the last computation concerns the Error Vector Magnitude (EVM), which is the most widely used metric to express the modulation quality in wireless communication systems. Basically, it is a measure of the signal constellation deviation from its ideal reference. It is computed from error vectors defined in the I-Q plane at the instants in time when symbols are detected, and therefore takes into account both phase and amplitude errors. EVM is defined as the RMS amplitude of the error vector over a sequence of emitted symbols, normalized to ideal signal amplitude reference:

$$EVM(\%) = \frac{\sqrt{\frac{1}{N} \sum_{j=1}^N (\delta I_j^2 + \delta Q_j^2)}}{A_{max}} * 100 \quad (13)$$

with:

$$\delta I_j = A(t_j) \cos(\varphi(t_j)) - A_{max} \cos(\varphi_{ref}(t_j)) \quad (14)$$

$$\delta Q_j = A(t_j) \sin(\varphi(t_j)) - A_{max} \sin(\varphi_{ref}(t_j)) \quad (15)$$

For ZigBee products, IEEE Std 802.15.4™ specifies normalization with the maximum signal amplitude. Also note that for the OQPSK modulation format, the computation is slightly adapted to take into account the one-bit period offset between I and Q data ( $\delta I_j$  and  $\delta Q_j$  are evaluated at different instants separated by one-bit period). In this case, the computed value is called Offset Error Vector Magnitude (OEVM).

#### V. RESULTS

##### A. Principle validation

The first experiment has been conducted with a theoretical tester period  $T_{cycle} = 0.125ns$ , which corresponds to a sampling frequency  $f_s = 64GHz$ . Obviously, such a high sampling frequency is not achievable with a standard ATE. However, the purpose of this experiment is to validate the principle of the proposed strategy, and in particular the modulation encoding scheme. Indeed, using a high sampling frequency permits a fine adjustment of the instantaneous frequency of the generated square-wave, and therefore a small discretization of the phase modulation encoded in the signal. Hence, we assume that the additional frequency components created by the discretization do not significantly modify the expected spectrum of the square-wave signal.

To illustrate this point, Figure 7 shows the spectrum of the base square-wave signal computed on 512 DSSS bits for the frequency range from DC to 6GHz. The harmonic components located at odd multiples of the base square-wave frequency are clearly visible and with a much higher magnitude than any other frequency component.

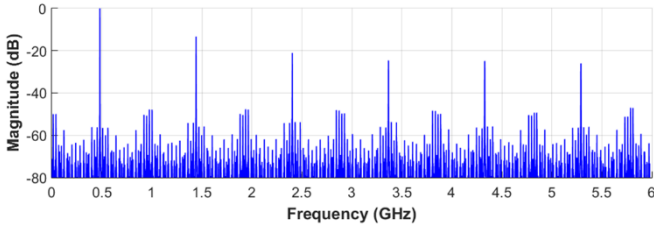

Fig. 7. Spectrum of base square-wave (full frequency range)

Then, to visualize the modulation encoded in this signal, we take a close look around its main components with a frequency span of 10MHz (Figure 8). The first comment is that the spectrum observed around each harmonic component indeed corresponds to the spectrum of a phase-modulated signal. As expected, we observe an attenuation in the spectrum magnitude for the 3<sup>rd</sup> and 5<sup>th</sup> harmonic components, and an enlargement of the bandwidth that reveals an increase of the modulation index. The spectrum obtained around the 5<sup>th</sup> harmonic component actually corresponds to the characteristic spectrum of a ZigBee signal, with a principal lobe about 2MHz wide centered at 2.405GHz surrounded by well-defined side lobes spaced 1MHz apart and with a strong attenuation compared to the principal lobe. This result therefore validates the encoding scheme of the square-wave signal.

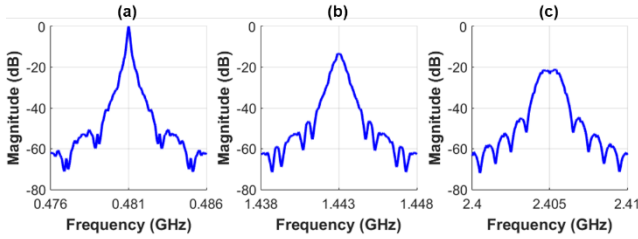

Fig. 8. Close look around: (a) base-frequency, (b) third harmonic, and (c) fifth harmonic

To corroborate this result, the quality metrics defined in the previous section have been computed on the signal obtained after application of a filter centered on the 5<sup>th</sup> harmonic, varying the filter bandwidth between 10MHz and 80MHz by step of 10MHz. Results are summarized in Table I that reports the NRMS value of the phase error, the NRMS value of the amplitude fluctuation and the achieved OEVM for the different values of the filter bandwidth. Whatever the filter bandwidth, the filtered signal presents very low phase error ( $<0.26\%$ ), very low amplitude fluctuation ( $<0.12\%$ ) and very low OEVM ( $<0.28\%$ ). These results demonstrate that, when modulation encoding is performed with a high sampling frequency, the proposed strategy enables the generation of a high-quality RF signal with the desired characteristics.

TABLE I. QUALITY METRICS OF THE GENERATED SIGNAL ( $f_s = 64\text{GHz}$ ) FOR DIFFERENT VALUES OF THE FILTER BANDWIDTH

	Filter Bandwidth (MHz)							
	10	20	30	40	50	60	70	80
NRMS- $\delta\phi$ (%)	0.16	0.07	0.05	0.08	0.13	0.28	0.22	0.25
NRMS- $\delta A$ (%)	0.12	0.02	0.01	0.01	0.02	0.02	0.02	0.02
OEVM (%)	0.27	0.08	0.05	0.04	0.04	0.04	0.05	0.05

As an illustration, Figure 9 compares the spectrum of the ideal RF modulated signal with the one of the generated signal in case of a 40MHz bandwidth filter (normalization with respect to maximum magnitude). An excellent agreement is observed between both spectrums.

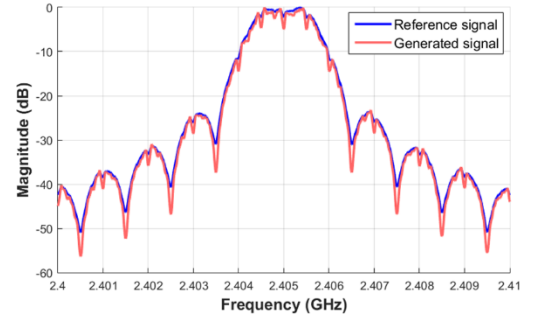

Fig. 9. Comparison between ideal RF signal spectrum and generated RF signal spectrum ( $f_s = 64\text{GHz}$ ,  $BW = 40\text{MHz}$ )

### B. Validation taking into account digital ATE capabilities

Further experiments have been conducted with a tester period compatible with the capabilities of a standard digital ATE. More precisely, simulations have been performed for the 34 possible values of the tester period ranging from 5ns up to 8.3ns (cf. Section III.C), varying here again the filter bandwidth between 10MHz and 80MHz by step of 10MHz.

Results are summarized in Figure 10, which presents a color chart representative of the signal quality for the different simulated conditions, in terms of OEVM values computed on the filtered signal. Several comments arise from the analysis of this chart. First, we can observe that a limited number of cases leads to a signal with a good modulation quality: only 46 among 272 simulated cases lead to a signal with an OEVM inferior to 2.5%. Then, it is impossible to identify a general trend with respect to the tester period. For instance, considering a filter bandwidth of 20MHz, a good OEVM is obtained by using 7.3ns tester period, a bad OEVM by using 7.4ns, and again a good OEVM by using 7.5ns. Finally, regarding the influence of the filter bandwidth, there is globally a trend that the smaller the bandwidth, the lower the OEVM. However, the situation significantly differs depending on the tester period. For instance, there is a smooth OEVM degradation as the filter bandwidth enlarges in case of 5.9ns tester period, but a severe degradation as soon as the

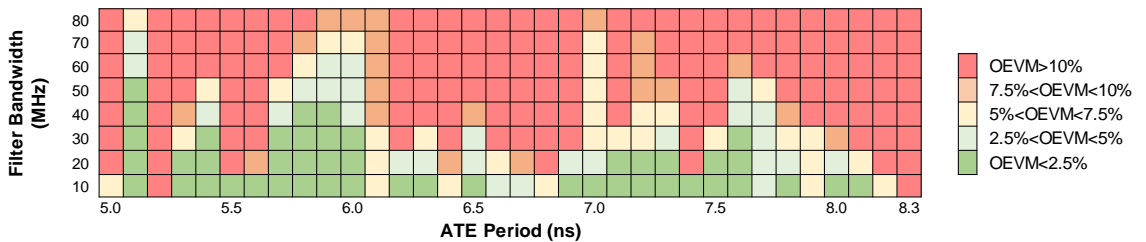

Fig.10. OEVM vs. ATE period and filter bandwidth



filter bandwidth increases from 10MHz to 20MHz in case of 5.5ns.

TABLE II. QUALITY METRICS OF THE GENERATED SIGNAL ( $f_s = 1.569GHz$ ) FOR DIFFERENT VALUES OF THE FILTER BANDWIDTH

	Filter Bandwidth (MHz)							
	10	20	30	40	50	60	70	80
NRMS- $\delta\phi$ (%)	0.47	0.85	1.36	1.74	2.07	2.41	2.80	3.24
NRMS- $\delta A$ (%)	0.23	0.31	0.32	0.44	0.44	0.56	0.88	1.24
OEVM (%)	0.60	0.67	1.18	1.67	2.32	3.10	4.12	5.28

From these experiments, the best setting clearly appears as the choice of a tester period  $T_{cycle} = 5.1ns$ , which corresponds to a sampling frequency  $f_s = 1.569GHz$ . Table II reports the quality metrics obtained in this case, for the different values of the filter bandwidth. Compared to the previous experiment where the encoding and the generation of the square-wave signal was done with a high sampling frequency, there is a clear degradation of computed metrics. However, it is still possible to achieve a good-quality signal, provided the use of a filter with a relatively small bandwidth. Concretely, a filter bandwidth of 40MHz is easily achievable using commercially available products. In this case, the generated signal exhibits a NRMS phase error below 2%, a NRMS amplitude fluctuation below 0.5% and an OEVM value around 1.7%. Such quality is largely sufficient to use the generated signal as stimulus for the test of ZigBee receivers.

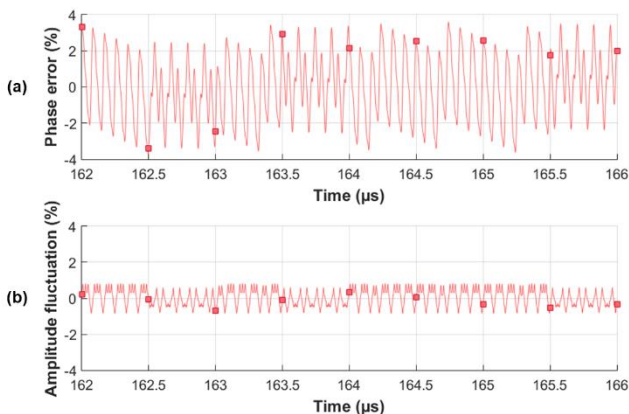

Fig.11. Phase error (a) and amplitude fluctuation (b) of generated signal ( $f_s = 1.569GHz$ ,  $BW = 40MHz$ )

To further illustrate the quality of the generated signal, Figure 11 shows the time-domain behavior of the phase error and of the amplitude fluctuation (zoom on 4 bits of the DSSS sequence, markers indicate values sampled for I/Q data used in OEVM computation). It can be observed that the maximum phase error does not exceed 3.8%, and the amplitude fluctuation is contained below 1%.

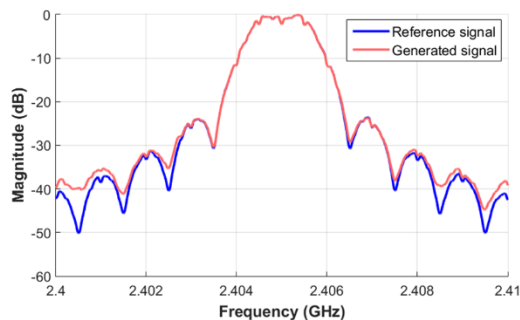

Fig.12: Comparison between ideal RF signal spectrum and generated RF signal spectrum ( $f_s = 1.569GHz$ ,  $BW = 40MHz$ )

Finally, Figure 12 compares the spectrum of the generated signal with the spectrum of the ideal RF modulated signal (normalization with respect to maximum magnitude). A good agreement can be observed, validating the chosen solution.

## VI. CONCLUSION

In this paper, we have explored a digital-based solution for the generation of 2.4GHz OQPSK test stimuli. The principle relies on an appropriate encoding of a square-wave-signal generated by a digital ATE associated with harmonic filtering. A dedicated pre-processing algorithm has been developed to determine the digital sequence that has to be stored in the ATE for the generation of the base square-wave. The proposed solution has been evaluated through simulation experiments performed in the Matlab® environment. Results have shown that, despite the constraints imposed by the ATE, the generation of a good quality modulated RF signal can be achieved. The proposed solution has therefore the potential to significantly reduce the testing costs of ZigBee receivers, by enabling their test on a standard digital ATE. Future work will target the hardware validation of this strategy.

## ACKNOWLEDGMENT

This work has been carried out under the framework of PENTA-EUREKA project "HADES".

## REFERENCES

- [1] I. Kore et al., "Multi-site test of RF transceivers on low-cost digital ATE," Proc. IEEE International Test Conference (ITC), pp. 1-10, 2011.
- [2] C. H. Peng et al., "A novel RF self test for a combo SoC on digital ATE with multi-site applications," Proc. Int'l Test Conf. (ITC), pp. 1-8, 2014.
- [3] M. Ishida K. Ichiyama, "An ATE System for Testing RF Digital Communication Devices With QAM Signal Interfaces," IEEE Design & Test, vol. 33, no. 6, pp. 15-22, 2016.
- [4] T. Vayssade et al., "Power measurement and spectral test of ZigBee transmitters from 1-bit under-sampled acquisition," Proc. IEEE European Test Symposium (ETS), pp. 1-6, 2019.
- [5] T. Vayssade et al., "EVM measurement of RF ZigBee transceivers using standard digital ATE," Proc. IEEE Int'l Symp. on Defect and Fault Tolerance (DFT), pp. 1-6, 2020.
- [6] J-L. Huang, and K-T. Cheng, "A sigma-delta modulation based BIST scheme for mixed-signal circuits," Proc. Asian Design Automation Conf. (ASP-DAC), 2000, pp. 605-610, 2000.
- [7] H. Malloug et al., "Mostly digital design of sinusoidal signal generators for mixed-signal bist applications using harmonic cancellation," Proc. IEEE Int'l Mixed-Signal Testing Workshop (IMSTW), pp. 1-6, 2016.
- [8] S. David-Grignot et al., "Analytical study of on-chip generations of analog sine-wave based on combined digital signals," Proc. IEEE Int'l Mixed Signals Testing Workshop (IMSTW), pp. 1-5, 2017.
- [9] A. Banerjee et al., "Optimized digital compatible pulse sequences for testing of RF front end modules," Proc. Inter'l Mixed-Signals, Sensors and Systems Test Workshop (IMS3TW), pp. 1-6, 2010.
- [10] M. A. Zeidan et al., "Phase-Aware Multitone Digital Signal Based Test for RF Receivers," IEEE Trans. on Circuits and Systems I, vol. 59, no. 9, pp. 2097-2110, 2012.