



HAL
open science

Target set selection with maximum activation time

Lucas Keiler, Carlos V.G.C. Lima, Ana Karolinna Maia, Rudini Sampaio,
Ignasi Sau

► **To cite this version:**

Lucas Keiler, Carlos V.G.C. Lima, Ana Karolinna Maia, Rudini Sampaio, Ignasi Sau. Target set selection with maximum activation time. *Procedia Computer Science*, 2021, 195, pp.86-96. 10.1016/j.procs.2021.11.014 . lirmm-03772657

HAL Id: lirmm-03772657

<https://hal-lirmm.ccsd.cnrs.fr/lirmm-03772657v1>

Submitted on 8 Sep 2022

HAL is a multi-disciplinary open access archive for the deposit and dissemination of scientific research documents, whether they are published or not. The documents may come from teaching and research institutions in France or abroad, or from public or private research centers.

L'archive ouverte pluridisciplinaire **HAL**, est destinée au dépôt et à la diffusion de documents scientifiques de niveau recherche, publiés ou non, émanant des établissements d'enseignement et de recherche français ou étrangers, des laboratoires publics ou privés.

Target set selection with maximum activation time

Lucas Keiler

Dept. Computação, Centro de Ciências, Universidade Federal do Ceará, Fortaleza - CE, Brazil
lucas.keiler@hotmail.com

Carlos Vinicius Gomes Costa Lima 

Dept. Computação, Centro de Ciências, Universidade Federal do Ceará, Fortaleza - CE, Brazil
gclima@lia.ufc.br

Ana Karolinna Maia 

Dept. Computação, Centro de Ciências, Universidade Federal do Ceará, Fortaleza - CE, Brazil
karolmaia@ufc.br

Rudini Sampaio 

Dept. Computação, Centro de Ciências, Universidade Federal do Ceará, Fortaleza - CE, Brazil
rudini@ufc.br

Ignasi Sau 

LIRMM, Université de Montpellier, CNRS, Montpellier, France
ignasi.sau@lirmm.fr

Abstract

A *target set selection model* is a graph G with a threshold function $\tau : V \rightarrow \mathbb{N}$ upper-bounded by the vertex degree. For a given model, a set $S_0 \subseteq V(G)$ is a *target set* if $V(G)$ can be partitioned into non-empty subsets S_0, S_1, \dots, S_t such that, for $i \in \{1, \dots, t\}$, S_i contains exactly every vertex v having at least $\tau(v)$ neighbors in $S_0 \cup \dots \cup S_{i-1}$. We say that t is the *activation time* $t_\tau(S_0)$ of the target set S_0 . The problem of, given such a model, finding a target set of minimum size has been extensively studied in the literature. In this article, we investigate its variant, which we call TSS-TIME, in which the goal is to find a target set S_0 that maximizes $t_\tau(S_0)$. That is, given a graph G , a threshold function τ in G , and an integer k , the objective of the TSS-TIME problem is to decide whether G contains a target set S_0 such that $t_\tau(S_0) \geq k$. Let $\tau^* = \max_{v \in V(G)} \tau(v)$. Our main result is the following dichotomy about the complexity of TSS-TIME when G belongs to a minor-closed graph class \mathcal{C} : if \mathcal{C} has bounded local treewidth, the problem is FPT parameterized by k and τ^* ; otherwise, it is NP-complete even for fixed $k = 4$ and $\tau^* = 2$. We also prove that, with $\tau^* = 2$, the problem is NP-hard in bipartite graphs for fixed $k = 5$, and from previous results we observe that TSS-TIME is NP-hard in planar graphs and $W[1]$ -hard parameterized by treewidth. Finally, we present a linear-time algorithm to find a target set S_0 in a given tree maximizing $t_\tau(S_0)$.

2012 ACM Subject Classification Mathematics of computing \rightarrow Graph algorithms.

Keywords and phrases Target set selection, activation time, complexity dichotomy, fixed-parameter tractability, bounded local treewidth, planar graph, tree, bipartite graph.

Funding Supported by CAPES [88887.143992/2017-00] DAAD Probral and [88881.197438/2018-01] STIC AmSud, CNPq Universal [401519/2016-3], [425297/2016-0] and [437841/2018-9], FUNCAP [4543945/2016] Pronem, and French projects DEMOGRAPH (ANR-16-CE40-0028) and ESIGMA (ANR-17-CE23-0010).

1 Introduction

In the *target set selection model* (TSS model for short), as formulated by Chen [20], it is given an undirected graph $G = (V, E)$ and a *threshold function* τ in G , which is a function $\tau : V(G) \rightarrow \mathbb{N}$ satisfying $1 \leq \tau(v) \leq d(v)$ for every vertex v , where $d(v)$ is the degree of v . We say that a set $S_0 \subseteq V(G)$ is a *target set* if the vertex set $V(G)$ can be partitioned into non-empty subsets S_0, S_1, \dots, S_t such that, for $i \in \{1, \dots, t\}$, S_i contains exactly every vertex v outside $S_0 \cup \dots \cup S_{i-1}$ having at least $\tau(v)$ neighbors in $S_0 \cup \dots \cup S_{i-1}$. We say that t is the *activation time* $t_\tau(S_0)$ of the target set S_0 , since this represents an activation process starting with S_0 : initially all vertices in the target set S_0 become *active*, the other vertices are *inactive*, and active vertices remain active forever (that is, it is an irreversible and monotone process). At any step of the process, each inactive vertex gets activated if the number of its active neighbors is at least its threshold. The process is synchronous, that is, all inactive vertices update their status at the same time in each step of the process.

The INFLUENCE MAXIMIZATION problem, that consists in finding a subset of vertices of size k that maximizes the expected number of vertices activated by the process described above in a given graph, was first studied by Kempe et al. [44, 45] with thresholds randomly chosen from a given range. The TSS model defined above (with deterministic thresholds) was introduced in [20], where the considered problem was to find a target set S_0 of minimum size. Let us call this problem TSS-SIZE. Since then, a number of articles investigated the TSS-SIZE problem [1, 9, 10, 21, 22, 25, 35, 52].

For a TSS model, there may exist different targets sets (of minimum size or not), yielding different activation times. Motivated by a recent line of research arising from a question of Bollobás on extremal properties of a closely related model discussed below (see the introduction of [53] and [48] for a detailed discussion), we define the following parameter: the *maximum activation time* $t_\tau(G)$ of a TSS model (G, τ) is the maximum $t_\tau(S_0)$ among all target sets S_0 of G . We consider the complexity of the decision version of the problem of determining $t_\tau(G)$, defined as follows.

TARGET SET SELECTION-TIME (TSS-TIME)

Instance: A graph $G = (V, E)$, a threshold function $\tau : V(G) \rightarrow \mathbb{N}$, and a positive integer k .

Question: Is $t_\tau(G) \geq k$?

For an instance (G, τ, k) of the TSS-TIME problem, we let $\tau^* := \max_{v \in V(G)} \tau(v)$. To the best of our knowledge, the above problem had not been considered before (we discuss related work in the next paragraph). Clearly, we may assume G as connected, since otherwise we may solve the problem independently in each connected component. Intuition suggests that the maximum time of activation processes might be obtained with minimum target sets, but this is not true in general. For example, Figure 1 depicts a tree T formed by a root vertex v together with $k + 1$ disjoint induced paths on t vertices, v being adjacent to an endvertex of each path, for positive integers t and $k > 1$. The thresholds are in red and the target sets are marked in gray. Figure 1a represents the (unique) minimum target set S of T of size one (containing the root v) with activation time t (achieved at the leaves of T). Figure 1b shows a target set S' of size k given by any k leaves of T , with activation time $2t$ (achieved at the leaf labeled $u_{t, k+1}$). Thus, the difference between the cardinalities of a minimum target set and of a target set achieving the maximum activation time can be arbitrarily large.

There are several recent articles in the literature dealing with problems similar to TSS-TIME, but considering different models or different activation processes. For example, the

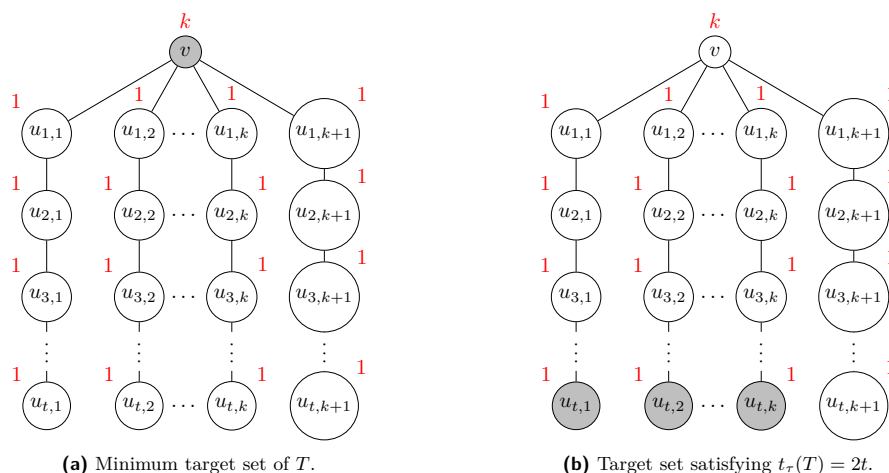

■ **Figure 1** A tree T with (unique) minimum target set S of size one and $t_\tau(S) = t$, and such that $t_\tau(G) = 2t$, for any positive integer t . The thresholds are in red, while the vertices of S and S' are marked in gray in [Figure 1a](#) and [Figure 1b](#), respectively.

r -neighbor bootstrap percolation model [2–6, 18, 42, 51, 54] is almost equivalent to the TSS model with all thresholds being equal to r but it accepts thresholds greater than the degree of a vertex. Motivated by this, we define a *generalized threshold function* in a graph G as any function $\tau' : V(G) \rightarrow \mathbb{N}$. Thus, a threshold function τ is a generalized threshold function satisfying $1 \leq \tau(v) \leq d(v)$ for any vertex v of G . Let the *generalized TSS model* be the analogous of TSS model with generalized threshold functions, instead of threshold functions. Hence, for an integer $r > 0$, the r -neighbor bootstrap percolation model is equivalent to the generalized TSS model with all thresholds equal to r . The r -NEIGHBOR BOOTSTRAP PERCOLATION-TIME and GENERALIZED TARGET SET SELECTION-TIME (GTSS-TIME for short) problems are defined analogously to TSS-TIME for the corresponding models. Observe that, for those problems, vertices whose threshold is greater than its degree must be in any target set (activation time 0) and vertices with threshold 0 are always activated at time at most 1.

Considering the 2-neighbor bootstrap percolation model and the parameter $t_{P_3}(G)$ (the analogous to the parameter $t_\tau(G)$ defined above for our problem), Przykucki [53] determined the value of the maximum percolation time on the hypercube $2^{[n]}$ as a function of n , and Benevides and Przykucki [13, 14] obtained similar results for the square grid $[n]^2$. It was also proved that deciding whether $t_{P_3}(G) \geq k$ is polynomial-time solvable for fixed $k \leq 3$ [48], and NP-complete for fixed $k \geq 4$ [11]. In bipartite graphs, it is polynomial-time solvable for fixed $k \leq 4$ and NP-complete for fixed $k \geq 5$ [48]. Finally, it was proved in [50] that 2-NEIGHBOR BOOTSTRAP PERCOLATION-TIME is W[1]-hard parameterized by the treewidth of the input graph. Clearly, all these hardness results extend to GENERALIZED TSS-TIME. However, they cannot be applied directly to TSS-TIME, since all these hardness reductions use vertices of degree 1, which have an important role in them, and which are not allowed in our setting when all thresholds are equal to 2.

In the GEODESIC (RESP. MONOPHONIC) CONVEXITY-TIME problem, threshold functions are not taken into account, and at any step of the activation process, each inactive vertex gets activated if it is in a shortest (resp. induced) path between two activate vertices. The maximum activation time obtained in these processes has been studied [12, 26, 40]. For each parameter, deciding if its value is greater or equal to k (for fixed k) is NP-complete when

$k \geq 2$ and $k \geq 1$, respectively, and the input graph is bipartite [12, 26]. Both problems are polynomial-time solvable for distance-hereditary graphs [12].

With respect to the parameterized complexity of these problems, the published articles mainly focus on the generalized version of the TSS-SIZE problem, for which there are no degree restrictions on the threshold function, denoted by GENERALIZED TSS-SIZE, and the cases in which the maximum threshold is small or the threshold of every vertex is at least half of its degree. Namely, GENERALIZED TSS-SIZE is FPT parameterized by the size of a minimum vertex cover [7, 52], and W[1]-hard for each of the following parameterizations: distance to cluster [22], neighborhood diversity [34], and distance to forest and pathwidth [52]. The case when all thresholds are exactly half of the degree for each vertex is also W[1]-hard parameterized by pathwidth [22]. For constant thresholds, the problem becomes FPT parameterized by distance to cluster [22], by neighborhood diversity [34], and by treewidth [10]. Ben-Zwi et al. [10] also proved that TSS-SIZE cannot be solved in $\mathcal{O}(n^{\sqrt{\text{tw}(G)}})$ time, where n and $\text{tw}(G)$ denote the number of vertices and the treewidth of the input graph G , respectively. Recently, Hartmann [41] gave an FPT algorithm for TSS-SIZE parameterized by clique-width and the maximum value of the threshold function. Cicalese et al. [23, 24] considered the problem in which the number of rounds of the process is bounded. For graphs of bounded clique-width, given parameters a, b, ℓ , they gave polynomial-time algorithms to determine whether there exists a target set of size b , such that at least a vertices are activated in at most ℓ time steps.

Our results and techniques. In this paper we initiate an analysis of the computational complexity of the TSS-TIME problem, in particular from the viewpoint of parameterized complexity. We start by showing that reductions of [11] and [50] for the 2-NEIGHBOR BOOTSTRAP PERCOLATION-TIME problem can be easily adapted in order to prove that TSS-TIME is NP-hard in planar graphs and graphs of bounded degree, and W[1]-hard when parameterized by the treewidth of the input graph (Corollary 7). We then provide NP-completeness results for fixed values of the activation time k and the value $\tau^* = \max_{v \in V(G)} \tau(v)$. Namely, by adapting another reduction in [11] from 3-SAT, we prove (Theorem 8) that TSS-TIME is NP-complete in general graphs for any fixed $k \geq 4$ and $\tau^* = 2$. This result is sharp in terms of τ^* since, as we observe in Lemma 6, the problem can be easily solved in polynomial time when $\tau^* = 1$. By reducing from the RESTRICTED PLANAR 3-SAT problem [29] instead of 3-SAT and modifying appropriately the planar embedding given by the incidence graph of the formula, we prove (Theorem 9) that TSS-TIME remains NP-complete for any fixed $k \geq 4$ and $\tau^* = 2$ even if the input graph is an apex graph, that is, a graph in which there exists a vertex whose removal yields a planar graph. Finally, by modifying the reduction of Theorem 8 by using bipartite gadgets, we prove (Theorem 11) that TSS-TIME is NP-complete in bipartite graphs for any fixed $k \geq 5$ and $\tau^* = 2$.

Motivated by these NP-completeness results, we study the parameterized complexity of the TSS-TIME problem considering k and τ^* as parameters. We manage to provide a dichotomy on the complexity of TSS-TIME when the input graph G belongs to a minor-closed graph class \mathcal{C} . Namely, we prove (Theorem 16) that if \mathcal{C} has bounded local treewidth (cf. Section 2 for the definition), then TSS-TIME is FPT with parameters k and τ^* ; otherwise it is NP-complete for any fixed $k \geq 4$ and $\tau^* = 2$. Note that, as discussed above, TSS-TIME is NP-hard in planar graphs (even with $\tau^* = 2$), which is a minor-closed graph class of bounded local treewidth, and therefore in our complexity dichotomy, “FPT” cannot be replaced by “solvable in polynomial time”. It is pertinent to mention here that the title of the article of Ben-Zwi et al. [10] is “treewidth governs the complexity of target set selection”, referring to the TSS-SIZE problem. In this spirit, one of the the main conclusions of our article is

that “local treewidth governs the complexity of target set selection with maximum activation time”. Let us now discuss how we prove [Theorem 16](#).

In order to prove this dichotomy, on the positive side we provide ([Theorem 15](#)) an FPT algorithm for the generalized version of the problem, namely GTSS-TIME, with parameters k and τ^* when the input graph G belongs to a graph class \mathcal{C} of bounded local treewidth (not necessarily minor-closed). In order to do this, we first observe ([Lemma 12](#)) that, for any instance (G, τ, k) of GTSS-TIME, $t_\tau(G) \geq k$ if and only if there exists a target set activating G at time *exactly* k . We then show ([Lemma 13](#)) that GTSS-TIME on an n -vertex graph G can be reduced to solving n instances having as input the graph induced in G by the k -th neighborhood of each vertex of G . The crucial observation is that, when G belongs to a class of bounded local treewidth, these auxiliary graphs have treewidth bounded by a function of k . With this at hand, we show ([Lemma 14](#)) that GTSS-TIME can be expressed by a monadic second-order logic formula whose length depends only on k and τ , and applying Courcelle’s Theorem [[27](#)] on the linearly many bounded-treewidth auxiliary graphs yields the desired FPT algorithm. Note that, since we deal with the generalized version of the TSS-TIME problem, our FPT algorithm also applies to the 2-NEIGHBOR BOOTSTRAP PERCOLATION problem. As particular cases of graph classes with bounded local treewidth, the existence of an FPT algorithm for 2-NEIGHBOR BOOTSTRAP PERCOLATION with parameter k in graphs with bounded maximum degree was already known [[49](#)], but no FPT algorithm in planar graphs (or, more generally, graphs of bounded genus) existed prior to our work. Note that 2-NEIGHBOR BOOTSTRAP PERCOLATION has been proved to be NP-complete in planar graphs by Benevides et al. [[11](#)]. In this NP-completeness proof, the authors say that “our proof does not work when the time is fixed”; the FPT algorithm of [Theorem 15](#) provides a solid explanation for that.

As for the hardness part of our complexity dichotomy, we critically use a result of Eppstein [[36](#)] stating that, for minor-closed graph classes, having bounded local treewidth is equivalent to excluding some apex graph. Now, if \mathcal{C} is a minor-closed graph class of unbounded local treewidth, the previous result implies that \mathcal{C} contains all apex graphs, in particular those originated from our hardness result of [Theorem 9](#) for apex input graphs, and therefore the TSS-TIME problem is NP-complete in \mathcal{C} for any fixed $k \geq 4$ and $\tau^* = 2$. Again, the same argument applies to 2-NEIGHBOR BOOTSTRAP PERCOLATION-TIME ([Corollary 10](#)), hence the dichotomy in minor-closed graph classes holds for this problem as well.

Finally, we provide ([Theorem 19](#)) an $\mathcal{O}(n)$ -time algorithm for the maximization version of TSS-TIME in trees, that is, for finding the maximum activation time of a target selection model (T, τ) where T is a tree. Note that the FPT algorithm of [Theorem 15](#) implies that deciding whether $t_\tau(T) \geq k$ for a tree T (which has treewidth one) can be solved in time $f(k, \tau^*) \cdot n^{\mathcal{O}(1)}$ for some function f , but we provide a stronger result by showing that also the *maximum* activation time of a tree can be computed in polynomial (even linear) time. In order to achieve this, we prove ([Lemma 18](#) and [Theorem 19](#)) that every path such that any internal vertex v satisfies $\tau(v) < d(v)$ (we say that such a v is *non-saturated*) can be activated one vertex per time step by some target set. With this, we prove that the maximum activation time in a tree is equal to the size of a maximum path such that all internal vertices are non-saturated. One interesting point here is that the threshold values are not important, but only whether a vertex is saturated or not. We generalize this algorithm ([Theorem 22](#)) to the maximization version of GTSS-TIME, namely, we provide an $\mathcal{O}(n^2)$ -time algorithm for finding the maximum activation time of a tree T and a generalized threshold function τ in T . The main idea is that any target set must contain the set V_f of “forced” vertices containing any vertex v with $\tau(v) > d(v)$. With this, we start the activation process from V_f , obtaining

the set $H(V_f)$ containing the vertices that can be activated by V_f . We then look for certain paths representing an activation sequence, whose first vertices are activated by V_f and whose last vertices are non-saturated. In this case, the threshold values are important, since $H(V_f)$ depends on them.

Organization. In [Section 2](#) we provide basic preliminaries about graphs, convexity, parameterized complexity, graph minors, (bounded local) treewidth, and monadic second-order logic. In [Section 3](#) we present our NP-completeness results, and in [Section 4](#) we provide the FPT algorithms for graphs of bounded local treewidth. Altogether, the results in [Section 3](#) and [Section 4](#) yield the complexity dichotomy for graph classes of bounded local treewidth. [Section 5](#) is devoted to the polynomial-time algorithms for trees. We conclude the paper in [Section 6](#) with some directions for further research.

2 Preliminaries

Graphs. We refer the reader to [\[30\]](#) for basic background on graph theory, and recall here only some useful definitions. We consider only undirected graphs without loops nor multiple edges. We will use n and m for denoting the number of vertices and edges, respectively, of the input graph of the problem under consideration. We denote by uv an edge between vertices u and v . For a graph G and a vertex set $S \subseteq V(G)$, we use the shortcut $G \setminus S$ to denote $G[V(G) \setminus S]$. The *distance* between two vertices u and v in a graph G is the number of edges of a shortest path between u and v . The *diameter* of G is the maximum distance over all pairs of vertices of G . For a vertex v in G and a positive integer k , we denote by $N_k(v)$ the set of vertices of G within distance at most k from v , and we let $N_k[v] = N_k(v) \cup \{v\}$. We abbreviate $N_1(v)$ and $N_1[v]$ as $N(v)$ and $N[v]$, respectively, and we let $d(v) = |N(v)|$ be the *degree* of v in G . A *tree* is a connected acyclic graph, and a *leaf* in a tree is a vertex of degree one.

For two non-negative integers a and b , we denote by $[a, b]$ the set containing every integer c such that $a \leq c \leq b$ and we let $[a] = [1, a]$. If a set S is partitioned into pairwise disjoint sets S_1, \dots, S_k , we denote it by $S = S_1 \uplus \dots \uplus S_k$.

Convexity. Activation problems appear in the literature under a number of different names, such as r -neighbor bootstrap percolation [\[2–6, 18, 42, 51, 54\]](#), dynamic monopolies [\[15, 19, 46, 55, 58\]](#), irreversible conversion [\[17, 43, 47, 56\]](#), or graph convexities, and were studied by researchers of various fields. As mentioned in the introduction, in the particular case in which all thresholds are equal to 2, generalized TSS model is also called 2-neighbor bootstrap percolation or P_3 -convexity, which is studied in the field of graph convexities.

A finite *graph convexity* [\[57\]](#) is a pair (G, \mathcal{C}) consisting of a finite simple graph $G = (V, E)$ and a set \mathcal{C} of subsets of V (called *convex sets*) satisfying that $\emptyset, V \in \mathcal{C}$ and that if $C_1, C_2 \in \mathcal{C}$, then $C_1 \cap C_2 \in \mathcal{C}$. In words, \emptyset and V are convex sets and the intersection of convex sets is a convex set. The *convex hull* $H_{\mathcal{C}}(S)$ of a set S is the minimum convex set containing S , that is, $H_{\mathcal{C}}(S)$ is the intersection of all convex sets containing S . When $H_{\mathcal{C}}(S) = V$ then S is a *hull set* of G . Some well-studied graph convexities are the so-called *path convexities*, such as the P_3 -convexity [\[37\]](#), geodesic convexity [\[38\]](#), and monophonic convexity [\[33\]](#).

In the following, we show that instances of the generalized TSS model induce graph convexities in most cases. Let (G, τ) be an instance of the generalized TSS model, where $G = (V, E)$ is a graph and $\tau : V \rightarrow \mathbb{N}$ is a generalized threshold function. For every set $S \subseteq V$, let the *interval* $I_{\tau}(S) \supseteq S$ be the union of the set S with the set of all vertices v outside S which have $\tau(v)$ neighbors in S . From this, let \mathcal{C}_{τ} be the family of subsets S of V such that $I_{\tau}(S) = S$ (that is, no vertex v outside S has $\tau(v)$ neighbors in S).

► **Lemma 1.** *Given an instance (G, τ) of the generalized TSS model, where $G = (V, E)$ is a graph and $\tau : V \rightarrow \mathbb{N}$ is a generalized threshold function in G , the pair (G, \mathcal{C}_τ) is a graph convexity if and only if $V = \emptyset$ or all thresholds are strictly positive.*

Proof. We have to prove that $\emptyset, V \in \mathcal{C}_\tau$ and that if $C_1, C_2 \in \mathcal{C}_\tau$, then $C_1 \cap C_2 \in \mathcal{C}_\tau$. Clearly $V \in \mathcal{C}_\tau$ by vacuity, since there is no vertex outside V . Thus, if $V = \emptyset$, (G, \mathcal{C}_τ) is a graph convexity, since the only subset S of V is $S = \emptyset = V$. So assume that $V \neq \emptyset$.

First consider that there is a vertex v with threshold $\tau(v) = 0$. With this, we have that $S = \emptyset$ is not convex, since $v \notin S = \emptyset$ and v has $\tau(v) = 0$ neighbors in $S = \emptyset$. Then (G, \mathcal{C}_τ) is not a graph convexity.

Now assume that all thresholds are strictly positive. Therefore $S = \emptyset$ is convex, since any vertex v does not have $\tau(v)$ neighbors in $S = \emptyset$. Finally, consider two sets $S_1, S_2 \in \mathcal{C}_\tau$ and let $S = S_1 \cap S_2$. If $S_1 = V$ or $S_2 = V$, then $S = S_2$ or $S = S_1$, respectively, and hence $S \in \mathcal{C}_\tau$. So assume that $S_1 \neq V$ and $S_2 \neq V$, and let $v \in V \setminus S$. Then $v \notin S_1$ or $v \notin S_2$. Consider $v \notin S_1$. Since $S_1 \in \mathcal{C}_\tau$, v does not have $\tau(v)$ neighbors in S_1 and consequently does not have $\tau(v)$ neighbors in S . The case $v \notin S_2$ is analogous. Then $S = S_1 \cap S_2 \subseteq \mathcal{C}_\tau$. ◀

In this context, we can also define the *activation time* $t_\tau(S)$ of a vertex subset S (not necessarily a target set) as the minimum t such that $I_\tau^{t+1}(S) = I_\tau^t(S)$, where $I_\tau^k(S)$ is the k -th iterate of the interval function, defined recursively as $I_\tau^0(S) = S$ and $I_\tau^k(S) = I_\tau^{k-1}(I_\tau(S))$ for $k \geq 1$. We can also define $H_\tau(S)$ as $H_\tau(S) = I_\tau^{t_\tau(S)}(S)$. This definition of $H_\tau(S)$ is useful even when (G, \mathcal{C}_τ) is not a graph convexity (for example, when some thresholds are 0). Recall that a vertex subset S is a target set if $H_\tau(S) = V$. In this paper, we will use these notations $I_\tau(S)$ and $H_\tau(S)$. When τ is clear in the context, the subscript will be removed from the notations $I(S)$ and $H(S)$.

The study of complexity aspects related to the computation of graph convexity parameters have been the main goal of various recent papers [8, 12, 16, 26, 31, 49]. From Lemma 1, all known convexity parameters, such as the Carathéodory number, the Radon number, the Helly number and the convexity number [31] are meaningful in the TSS model and can be investigated in this context.

Parameterized complexity. We refer the reader to [28, 32] for basic background on parameterized complexity, and we recall here only the definitions used in this article. A *parameterized problem* is a language $L \subseteq \Sigma^* \times \mathbb{N}$. For an instance $I = (x, k) \in \Sigma^* \times \mathbb{N}$, k is called the *parameter*.

A parameterized problem L is *fixed-parameter tractable* (FPT) if there exists an algorithm \mathcal{A} , a computable function f , and a constant c such that given an instance $I = (x, k)$, \mathcal{A} (called an *FPT algorithm*) correctly decides whether $I \in L$ in time bounded by $f(k) \cdot |I|^c$.

Within parameterized problems, the class $W[1]$ may be seen as the parameterized equivalent to the class NP of classical decision problems. Without entering into details (see [28, 32] for the formal definitions), a parameterized problem being $W[1]$ -hard can be seen as a strong evidence that this problem is *not* FPT.

Minors, treewidth, and bounded local treewidth. A graph H is a *minor* of a graph G if H can be obtained from a subgraph of G by contracting edges. A graph class \mathcal{C} is *minor-closed* if whenever a graph G belongs to \mathcal{C} , all its minors belong to \mathcal{C} as well. A graph is *planar* if it can be drawn in the plane so that its edges may intersect only in the extremities. A graph G is an *apex graph* if it contains a vertex whose removal from G results in a planar graph.

Let $k \geq 0$ be an integer. A graph G is a *k-tree* if G can be obtained from a clique of size $k + 1$ by repeatedly adding vertices adjacent to a clique of size k of the current graph.

The *treewidth* of a graph G , denoted by $\text{tw}(G)$, is the smallest integer k such that G is a subgraph of a k -tree.

A graph class \mathcal{C} has *bounded local treewidth* if there exists a function $f : \mathbb{N} \rightarrow \mathbb{N}$ such that, for every graph $G \in \mathcal{C}$, every vertex $v \in V(G)$, and every positive integer k , $\text{tw}(G[N_k[v]]) \leq f(k)$. Examples of graph classes of bounded local treewidth are graphs of bounded treewidth, graphs of bounded degree, planar graphs, or graphs of bounded genus; see [39] for more on bounded local treewidth. The following theorem of Eppstein [36] states that, for minor-closed graph classes, having bounded local treewidth is equivalent to excluding some apex graph.

► **Theorem 2** (Eppstein [36]). *Let \mathcal{C} be a minor-closed graph class. Then \mathcal{C} has bounded local treewidth if and only if \mathcal{C} does not contain all apex graphs.*

Monadic second-order logic of graphs. The syntax of *monadic second-order logic* (MSO) of graphs includes the logical connectives \vee, \wedge, \neg , variables for vertices, edges, sets of vertices and sets of edges, the quantifiers \forall, \exists that can be applied to these variables, and the binary relations expressing whether a vertex or an edge belong to a set, whether an edge is incident to vertex, whether two vertices are adjacent, and whether two sets are equal. MSO_1 is the restriction of MSO where only quantification over sets of vertices (but not edges) is allowed. The following result of Courcelle [27] is one of the most widely used results in the area of parameterized complexity.

► **Theorem 3** (Courcelle [27]). *Checking whether an MSO formula ϕ holds on an n -vertex graph of treewidth at most tw can be done in time $g(\phi, \text{tw}) \cdot n$, for a computable function g .*

3 NP-completeness results for the TSS-time problem

In this section, we prove NP-completeness results for the TSS-TIME problem. Namely, we prove NP-completeness for general graphs in Theorem 8, for apex graphs in Theorem 9, and for bipartite graphs in Theorem 11. We begin by proving membership in NP.

Let $t_\tau(v, S_0)$ be the activation time of vertex v in the process initiated by S_0 (set $t(v, S_0) = \infty$ if S_0 cannot activate v). We first prove that, for every set S_0 , it is possible to compute $t_\tau(v, S_0)$ for every vertex v in time $\mathcal{O}(m + n)$. Also, let $t_\tau(S_0) = \max_{v \in V(G)} \{t_\tau(v, S_0)\}$. Thus, a vertex set S_0 is a target set if and only if $t_\tau(S_0) < \infty$.

► **Lemma 4.** *Let G be a graph and τ be a generalized threshold function in G . Given a set $S_0 \subseteq V(G)$, it is possible to compute $t_\tau(v, S_0)$ for all vertices v of G in time $\mathcal{O}(m + n)$.*

Proof. Consider the following algorithm. Let Q be an empty queue and t an array such that $t[v] = \infty$ for any $v \in V(G) \setminus S_0$. For each $v \in S_0$, set $t[v] = 0$ and enqueue v in Q . For each vertex $v \notin S_0$ with threshold 0, set $t[v] = 1$ and enqueue v in Q .

```

■ Algorithm ACTIVATION-TIMES (set  $S_0$ )
1  while  $Q \neq \emptyset$  do
2     $v \leftarrow \text{DEQUEUE}(Q)$ 
3    for each neighbor  $u$  of  $v$  with  $t[u] = \infty$  do
5       $\tau(u) \leftarrow \tau(u) - 1$ 
6      if  $\tau(u) = 0$  then
7         $t[u] \leftarrow t[v] + 1$ 
9        ENQUEUE( $Q, u$ )
10 return array  $t$ 

```

The above algorithm simulates the activation process. Since every edge is analyzed at most twice, $\text{ACTIVATION-TIMES}(S_0)$ runs in time $\mathcal{O}(m + n)$. ◀

With this, we have membership in NP for GTSS-TIME.

► **Corollary 5.** *The GTSS-TIME problem is in NP.*

Proof. Given an instance (G, τ, k) of GTSS-TIME, a certificate (or proof) for it is a vertex subset $S_0 \subseteq V(G)$. With the Algorithm ACTIVATION-TIMES , $t_\tau(v, S_0)$ can be computed for all $v \in V(G)$ in $\mathcal{O}(m + n)$ time. With this, $t_\tau(S_0)$ can be computed and compared with k . ◀

Before moving to the hardness results, consider first the GTSS-TIME problem with all thresholds being at most 1. Given a connected graph G , it is easy to see that one vertex is sufficient to activate all vertices. If there are vertices with threshold 0, then \emptyset is a target set and then $t_\tau(G) = t_\tau(\emptyset)$, which can be computed in linear time by the algorithm ACTIVATION-TIMES with $S_0 = \emptyset$. Otherwise, every single vertex is a target set and then $t_\tau(G)$ is the diameter of G , which can be computed in time $\mathcal{O}(m \cdot n)$. With this, we have the following:

► **Lemma 6.** *Let G be a graph and τ be a generalized threshold function in G satisfying $\tau^* \leq 1$. Then $t_\tau(G)$ can be computed in time $\mathcal{O}(m \cdot n)$. Thus, GTSS-TIME is $\mathcal{O}(m \cdot n)$ -time solvable if $\tau^* \leq 1$.*

Now let us consider the case where all thresholds are equal to 2. As mentioned in the introduction, the 2-neighbor bootstrap percolation model is equivalent to the generalized TSS model with all thresholds equal to 2. With this, let us list again shortly the existing hardness results for the 2-NEIGHBOR BOOTSTRAP PERCOLATION-TIME problem: NP-hardness in planar graphs [11], NP-hardness in general graphs for fixed $k = 4$ [11], NP-hardness in bipartite graphs for fixed $k = 5$ [48], NP-hardness in bounded degree graphs for $k = \Theta(\log n)$ [49], and W[1]-hardness when parameterized by treewidth [50]. All these hardness results also apply to GTSS-TIME with all thresholds equal to 2, but cannot be extended directly to TSS-TIME, since they use many vertices of degree 1, which have activation time 0 and are important to control the maximum activation time.

However, except in the case of bipartite graphs, it is possible to apply local changes to all these reductions by replacing every vertex p of degree 1 by two adjacent vertices p_1 and p_2 , forming a triangle with the original neighbor q of p (this is the reason why this replacement does not work in bipartite graphs). Consider any of the reductions mentioned above, and let (G, k) be the original constructed instance of 2-NEIGHBOR BOOTSTRAP PERCOLATION TIME, where G is the graph and k is the desired activation time. Let (G', k') be the instance where G' is the graph obtained from G with this modification and $k' = k + 1$. Since all thresholds are 2, we have that, for each vertex p of degree 1 in G , at least one of p_1 or p_2 (say p_1 w.l.g.) must be in any target set of G' and will play in G' the same role as p in G . Thus any target set S of G induces a target set S' of G' , which activates p_2 in one time step more than q . Now consider a target set S' of G' . One important point in all these reductions is that the neighbor q of any vertex p of degree 1 is always activated (with the help of p) by a forced set of vertices which must belong to any target set (hull set in their terminology) and this set remains forced when the above modification is applied in the construction. That is, for any vertex p of degree 1 in G , $S'' = (S' \cup \{p_1\}) \setminus \{p_2\}$ is also a target set of G' with activation time greater or equal to the activation time of S' . With this, we may assume that, for every vertex p of degree 1 in G , S' contains p_1 and does not contain p_2 , and consequently it induces a target set S in G (just replacing p_1 by p for any p

of degree 1 in G). Finally, in all these reductions, all vertices are activated at time at most $k - 1$ for any target set, except a special vertex z which can be activated at time k if the reduction is from a **yes**-instance. Moreover, z has exactly one neighbor p of degree 1 in G (in all these reductions) and consequently the corresponding neighbor p_2 of z in G' can be activated at time $k' = k + 1$. These modifications can be safely applied to the NP-hardness reductions for bounded degree graphs with $k = \Theta(\log n)$ [49] and planar graphs [11], and in the W[1]-hardness reduction when parameterized by treewidth [50], yielding the following corollary.

► **Corollary 7.** *The TSS-TIME problem is NP-hard in planar graphs, NP-hard in graphs with maximum degree Δ for any fixed $\Delta \geq 4$ and $k = \Theta(\log n)$, and W[1]-hard when parameterized by the treewidth of the input graph, even if all thresholds are equal to 2.*

In the case of the reduction for fixed $k = 4$ in general graphs [11], which is from the 3-SAT problem, this global argument does not work, since there is a unique vertex z whose activation time is 3 or 4, depending on whether the 3-SAT formula is satisfiable or not. However, by replacing every vertex p of degree 1 by p_1 and p_2 as before, the activation time of p_2 is one more than the time of q (the neighbor of p) and then the reduction fails for fixed $k = 4$ (but works for $k = 5$). With a small additional change, the reduction can be corrected for $k = 4$. In the following, we present this modified reduction, where we also have to show that no additional vertex (p_1 or p_2) can be activated at time 4. Moreover, although this reduction is similar to the one of [11], we present it in detail since we need to modify it in the proof of NP-hardness for apex graphs shown in [Theorem 9](#).

► **Theorem 8.** *The TSS-TIME problem is NP-complete even restricted to instances (G, τ, k) such that $\tau(v) = 2$ for every $v \in V(G)$, and $k \geq 4$ is fixed.*

Proof. We present a reduction from the 3-SAT problem. Let $\varphi = (\mathcal{X}, \mathcal{C})$ be an instance of 3-SAT, where $\mathcal{X} = \{x_1, \dots, x_n\}$ is the set of variables and $\mathcal{C} = \{C_1, \dots, C_m\}$ is the set of clauses. We may assume that each clause contains exactly 3 literals. For $i \in [n]$, we denote the three literals of clause C_i by $\ell_{i,1}$, $\ell_{i,2}$, and $\ell_{i,3}$. The constructed graph G is described below.

For every clause C_i , add the gadget depicted in [Figure 2](#). Let U , W , and B be the sets containing all vertices $u_{i,p}$, $w_{i,p}$, and $b_{i,p}$ for $p \in [3]$, respectively. Let $U_i = \{u_{i,1}, u_{i,2}, u_{i,3}\}$. For every pair of complementary literals $\ell_{i,p}, \ell_{j,q}$ for $i, j \in [n]$ and $p, q \in [3]$, add a vertex $y_{(i,p),(j,q)}$ adjacent to $w_{i,p}$ and $w_{j,q}$. Let Y be the set of all vertices $y_{(i,p),(j,q)}$. Finally, add six vertices $z, z_0, z_1, z_2, z_3, z_4$ and the edges $zz_0, z_0z_1, z_0z_2, z_0z_3, z_0z_4, z_1z_2$, and z_3z_4 . Also join z with an edge to every vertex of Y (see [Figure 3](#)). This completes the construction of the instance (G, τ, k) of TSS-TIME, where $k = 4$ and $\tau(v) = 2$ for every $v \in V(G)$. Notice that G does not contain vertices of degree 1, as required.

Firstly notice that, for $i \in [m]$ and $p \in [3]$, $a_{i,p}$ and $b_{i,p}$ cannot be activated only by $w_{i,p}$, since their degrees are equal to their thresholds (equal to two) and they are adjacent. That is, every target set must contain $a_{i,p}$ or $b_{i,p}$, say $a_{i,p}$ w.l.g.. The same argument applies to z_1 and z_2 (say z_1 w.l.g.) and to z_3 and z_4 (say z_3 w.l.g.). From this, we have that z_0 is activated at time 1 and z_2 and z_4 are activated at time 2. The important fact here is that z has a neighbor z_0 activated at time 1. Let L be the set containing vertices z_1, z_3 and all vertices $a_{i,p}$ for $i \in [m]$ and $p \in [3]$.

We show that φ is satisfiable if and only if G contains a target set with activation time at least 4. Suppose that φ has a truth assignment. For every clause C_i , let $k_i \in [3]$ be such that ℓ_{i,k_i} is set to true by the assignment. Let $S' = \{u_{i,k_i} : i \in [m]\}$ and $S = S' \cup L$. We

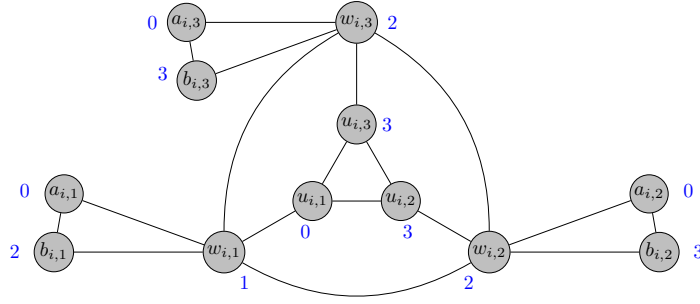

■ **Figure 2** Gadget for a clause C_i . All thresholds are 2. Notice that every target set must contain at least one of $u_{i,1}, u_{i,2}, u_{i,3}$ and at least one of $a_{i,p}, b_{i,p}$ for $p \in [3]$. The blue numbers near the vertices show the times of an example of activation process. Vertices with time 0 belong to the target set.

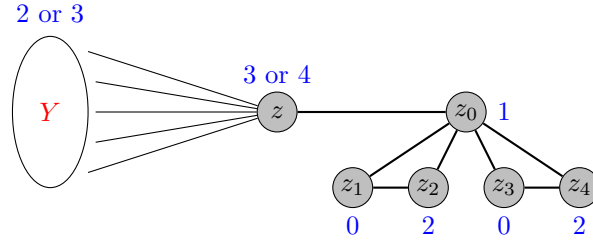

■ **Figure 3** Gadget of vertex z (the only which can have activation time 4). The blue numbers near the vertices show the times of an example of activation process. Vertices with time 0 belong to the target set.

show that S is a target set which activates z at time 4. At time 1, S activates z_0 and all vertices w_{i,k_i} for $i \in [m]$. At time 2, S activates z_2, z_4 , all vertices b_{i,k_i} for $i \in [m]$, and the remaining vertices of W . At time 3, S activates all the remaining vertices in U and B . All vertices in Y are activated by S at time exactly 3, since S was obtained from a truth assignment and then no vertex of Y has two neighbors activated at time 2. At time 4, S activates only vertex z . Thus, G has activation time at least 4.

Now, suppose that $t_\tau(G) \geq 4$ and let S be a target set S with activation time at least 4. As said before, we may assume that S contains L . Moreover, for every clause C_i , $U_i \cap S \neq \emptyset$ since $|N(u_{i,p}) \setminus U_i| \leq 1$, for any $i \in [m]$ and $p \in [3]$. With this, we have that S activates W at time at most 2, $B \cup U \cup Y$ at time at most 3, and vertex z at time 4. If S activates a vertex of Y at time 2, then z is activated at time 3 (with the help of z_0), a contradiction. Thus no vertex of Y is activated at time 2 or less, which implies that no pair $\{u_{i,p}, u_{j,q}\}$, where $\ell_{i,p}$ is the negation of $\ell_{j,q}$, is in S . This means that assigning true to each $\ell_{i,p}$ for which $u_{i,p} \in S$ yields an assignment that satisfies φ .

For time values $k > 4$, it suffices to add to G a new path P with $k - 5$ edges and $k - 4$ new vertices s_1, \dots, s_{k-4} , and the edge zs_1 . Moreover, for every vertex s_i of P , add five new vertices $s_{i,0}, s_{i,1}, s_{i,2}, s_{i,3}, s_{i,4}$ and seven edges $s_i s_{i,0}, s_{i,1} s_{i,2}, s_{i,3} s_{i,4}$, and $s_{i,0} s_{i,p}$ for $p \in [4]$. As before, the constructed graph G' has no vertex of degree 1. From this, it is easy to see that a target set S activates s_{k-4} at time k if and only if S activates z at time 4. ◀

The *variable-clause incidence graph* of a SAT formula $\varphi = (\mathcal{X}, \mathcal{C})$, where \mathcal{X} and \mathcal{C} are the variables and the clauses of φ , respectively, is the bipartite graph G_φ with vertex set $\mathcal{X} \cup \mathcal{C}$ such that, for $x \in \mathcal{X}$ and $c \in \mathcal{C}$, xc is an edge of G_φ if and only if clause c contains variable

x (either positively or negatively).

The RESTRICTED PLANAR 3-SAT problem is the variant of the SAT problem restricted to formulas φ such that

- each clause has two or three literals,
- each variable appears exactly twice positively and once negatively, and
- the variable-clause incidence graph of φ is planar.

Building on the proof of [Theorem 8](#) and exploiting the fact that RESTRICTED PLANAR 3-SAT is NP-complete [[29](#)], we get the following result.

► **Theorem 9.** *The TSS-TIME problem is NP-complete even restricted to instances (G, τ, k) such that G is an apex graph, $\tau(v) = 2$ for every $v \in V(G)$, and $k \geq 4$ is fixed.*

Proof. We present a polynomial reduction from the RESTRICTED PLANAR 3-SAT, which is NP-complete [[29](#)]. Given an instance $\varphi = (\mathcal{X}, \mathcal{C})$ of RESTRICTED PLANAR 3-SAT, let (G, τ, k) be the instance of TSS-TIME constructed in the proof of [Theorem 8](#) for the formula φ . If $C_i \in \mathcal{C}$ is a clause containing only two literals, we still use the same gadget depicted in [Figure 2](#), but removing the vertices $a_{i,3}, b_{i,3}, u_{i,3}$, and $w_{i,3}$. By the proof of [Theorem 8](#), it follows that $t_\tau(G) \geq k$ if and only if φ is satisfiable. It just remains to show that G is an apex graph. More precisely, we claim that the graph obtained from G by removing vertex z (see [Figure 3](#)) is planar. Clearly, it is enough to show that $G \setminus \{z, z_0, z_1, z_2, z_3, z_4\}$ is planar.

Let G_c be the graph obtained from $G \setminus \{z, z_0, z_1, z_2, z_3, z_4\}$ by doing the following operations. First, for every $i \in [m]$, contract all the vertices in the clause gadget of C_i to a single vertex. Then, for every $j \in [n]$, identify all vertices in Y corresponding to a pair of occurrences of x_j and \bar{x}_j . Since every variable appears positively and negatively in φ , it can be easily verified that G_c is isomorphic to the variable-clause incidence graph of φ . Therefore, G_c is a planar graph. Consider an arbitrary planar embedding of G_c , and we proceed to argue that it can be modified so to yield a planar embedding of $G \setminus \{z, z_0, z_1, z_2, z_3, z_4\}$. Note first that, for every $i \in [m]$, replacing the vertex in G_c corresponding to clause C_i by its clause gadget in G preserves planarity, since only the vertices $w_{i,1}, w_{i,2}, w_{i,3}$ have neighbors outside the gadget.

Now consider $j \in [n]$, and let $C_{j_1}, C_{j_2}, C_{j_3}$ be the three clauses of φ containing variable x_j . Equivalently, $C_{j_1}, C_{j_2}, C_{j_3}$ are the three neighbors of vertex x_j in the graph G_c . Since every variable appears twice positively and once negatively in φ , we may assume w.l.g. that C_{j_1} and C_{j_2} contain x_j positively, and that C_{j_3} contains x_j negatively. For $\ell \in [3]$, let w_{j_ℓ, p_ℓ} be the vertex in the clause gadget of C_{j_i} corresponding to x_j (see [Figure 2](#)). Note that, since every variable appears exactly once negatively in φ , there are exactly two vertices in $Y \subseteq V(G)$ associated with each variable x_j . We add back to the planar embedding constructed so far the two vertices in Y corresponding to x_j as shown in [Figure 4](#). Since no edge crossing is created by this construction, we have obtained a planar embedding of $G \setminus \{z, z_0, z_1, z_2, z_3, z_4\}$, and the theorem follows. ◀

The transformation described in the proof of [Theorem 9](#) can also be applied to the original NP-hardness proof of Benevides et al. [[11](#)] for the 2-NEIGHBOR BOOTSTRAP PERCOLATION-TIME problem, and therefore we get the following corollary.

► **Corollary 10.** *The 2-NEIGHBOR BOOTSTRAP PERCOLATION-TIME problem is NP-complete even restricted to instances (G, k) such that G is an apex graph and $k \geq 4$ is fixed.*

In [[48](#)], it was proved that the 2-NEIGHBOR BOOTSTRAP PERCOLATION-TIME problem is NP-complete in *bipartite* graphs for every fixed $k \geq 5$. As before, in the NP-hardness

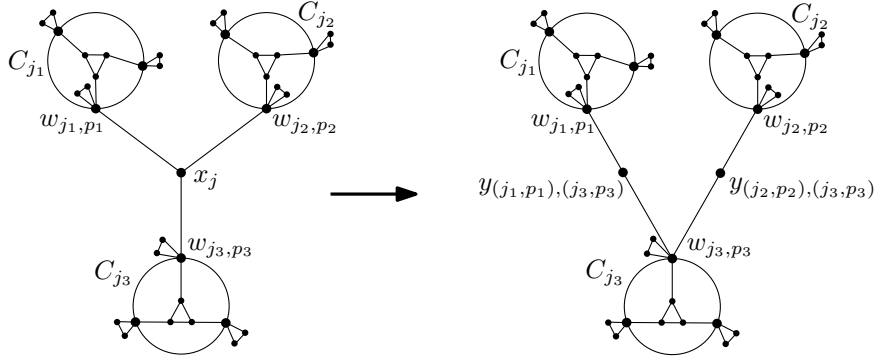

■ **Figure 4** Illustration of the local modification to the planar embedding of G_c so to add back the two vertices in $Y \subseteq V(G)$ associated with variable x_j , labeled $y_{(j_1,p_1),(j_3,p_3)}$ and $y_{(j_2,p_2),(j_3,p_3)}$ in the figure.

reduction of [48], the constructed graph has many vertices of degree 1, which are not allowed in the TSS model. In order to obtain a reduction to TSS-TIME with all thresholds equal to 2, we adapt appropriately the reduction of [48] in order to avoid vertices of degree 1. The solution to remove degree 1 vertices in the reduction of Theorem 8 involves many triangles of type $a_{i,j}, b_{i,j}, w_{i,j}$, which cannot be used here, since the graph must be bipartite. Therefore, we need to devise other gadgets.

► **Theorem 11.** *The TSS-TIME problem is NP-complete even restricted to instances (G, τ, k) such that G is a bipartite graph, $\tau(v) = 2$ for every $v \in V(G)$, and $k \geq 5$ is fixed.*

Proof. Let us prove that this restriction of the TSS-TIME problem is NP-complete by presenting, as in Theorem 8, a polynomial reduction from the 3-SAT problem (each clause contains exactly three literals).

In order to simplify the reduction, let us introduce some notation. A *squared vertex* h in the reduction represents the gadget of Figure 5 with auxiliary vertices $h_1, h_2, h_{11}, \dots, h_{26}$ all whose edges are represented in the figure. We assume that all thresholds are equal to 2. One important fact about squared vertices is that, for any target set, its activation time is always at most 2. This is because any target set must contain at least a vertex of each one of the following sets: $\{h_{11}, h_{14}\}$, $\{h_{12}, h_{15}\}$, $\{h_{13}, h_{16}\}$, $\{h_{21}, h_{24}\}$, $\{h_{22}, h_{25}\}$, and $\{h_{23}, h_{26}\}$ (otherwise the set is never activated). If h is not activated at time 0 or 1, then by the pigeonhole principle any target set contains at least two vertices in each one of $\{h_{14}, h_{15}, h_{16}\}$ and $\{h_{24}, h_{25}, h_{26}\}$. From this, h_1 and h_2 are activated at time 1 and consequently h is activated at time 2.

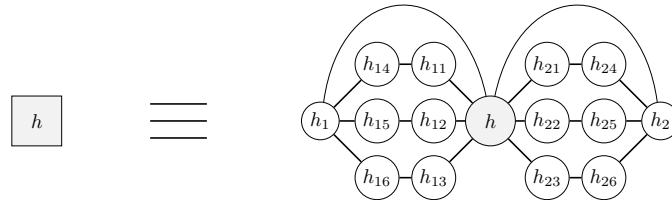

■ **Figure 5** Gadget of a squared vertex h , which is always activated at time at most 2.

A *double squared vertex* h in the reduction represents the gadget of Figure 6 with auxiliary

vertices $h', h_0, h_{01}, \dots, h_{06}$ all whose edges are represented in the figure (notice that h' is squared and also contains the edges in Figure 5).

One important fact about double squared vertices is that, for any target set, its activation time is always at most 3. This is because, with identical arguments as before, if h is not activated at time 0 and 1, h_0 is activated at time 1 and then h is activated at time at most 3, since h' is squared and is activated at time at most 2. Another important fact is that, if a neighbor of h outside the gadget of Figure 6 is activated at time 0 or 1, then h is activated at time at most 2 (since h_0 and this neighbor activate h).

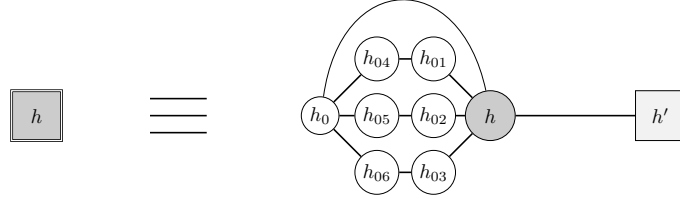

■ **Figure 6** Gadget of double squared vertex h , which is always activated at time at most 3. Moreover, if a neighbor of h outside this gadget is activated at time 0 or 1, h is activated at time at most 2.

Let $\varphi = (\mathcal{X}, \mathcal{C})$ be an instance of 3-SAT, where $\mathcal{X} = \{x_1, \dots, x_n\}$ is the set of variables and $\mathcal{C} = \{C_1, \dots, C_m\}$ is the set of clauses. Let us denote the three literals of C_i by $\ell_{i,1}$, $\ell_{i,2}$ and $\ell_{i,3}$. We proceed by constructing a graph G such that $t_\tau(G) \geq 5$ if and only if the 3-SAT instance is satisfiable.

For every clause C_i of \mathcal{C} , add to G the gadget of Figure 7. Let $W = \{w_{i,p} \mid i \in [m], p \in [3]\}$. For every pair of complement literals $\ell_{i,p}, \ell_{j,q}$, add a vertex $y_{(i,p),(j,q)}$ adjacent to $w_{i,p}$ and $w_{j,q}$. Let Y be the set of all vertices $y_{(i,p),(j,q)}$. Finally, add a vertex z adjacent to all vertices in Y and a squared vertex z' adjacent to z .

Notice that G has no vertex of degree 1, as required in the definition of threshold function. To prove that G is bipartite, consider the following partition (A, B) of the main vertices of G . A contains all vertices $u_{i,j}^A, a_{i,j}, h_{i,j}, y_{(i,p),(j,q)}$, and z' . B contains all vertices $u_{i,j}^B, w_{i,j}, b_{i,j}, c_{i,j}$, and z . Moreover, the gadgets of Figure 5 and Figure 6 are clearly bipartite.

Suppose that φ has a truth assignment. For every clause C_i , let $k_i \in [3]$ such that ℓ_{i,k_i} is true. We obtain a target set S of G as follows: S contains $u_{i,k_i}^A, b_{i,1}, b_{i,2}$, and $b_{i,3}$ for every clause C_i . Moreover, S contains the vertices $h_{j,4}, h_{j,5}$, and $h_{j,6}$ in Figure 5 and Figure 6 for every squared or double squared vertex. It is not difficult to see in Figure 7 that all vertices in the clause gadgets are activated by S at time at most 4. Also, for every clause C_i , we have that S activates w_{i,k_i} at time 2 and activates $w_{i,k'}$ at time 3 for $k' \in [3] \setminus \{k_i\}$. From the truth assignment, all vertices of Y are activated at time exactly 4, since every vertex $y \in Y$ is adjacent to exactly one vertex in W activated at time 2 and to another vertex in W activated at time 3. Thus, vertex z is activated at time 5 and consequently $t_\tau(G) \geq 5$.

Now, suppose that $t_\tau(G) \geq 5$ and let S be a target set with activation time at least 5. Then S has at least one vertex of every set U_i , since any vertex in U_i has only one neighbor outside U_i . Moreover, from the same argument, S contains $a_{i,p}$ or $b_{i,p}$ for every $p \in [3]$. It is not difficult to see in Figure 7 and Figure 8 that all vertices in the clause gadgets are activated by S at time at most 4 and all vertices of W are activated at time at most 3 (in the figures, S is represented by the vertices with activation time 0). We may assume w.l.g. that S contains $b_{i,p}$ instead of $a_{i,p}$, for $p \in [3]$, since $a_{i,p}$ activates $w_{i,p}$ at time at most 2. Also, all vertices of Y are activated at time at most 4. Also recall that z' is activated at time

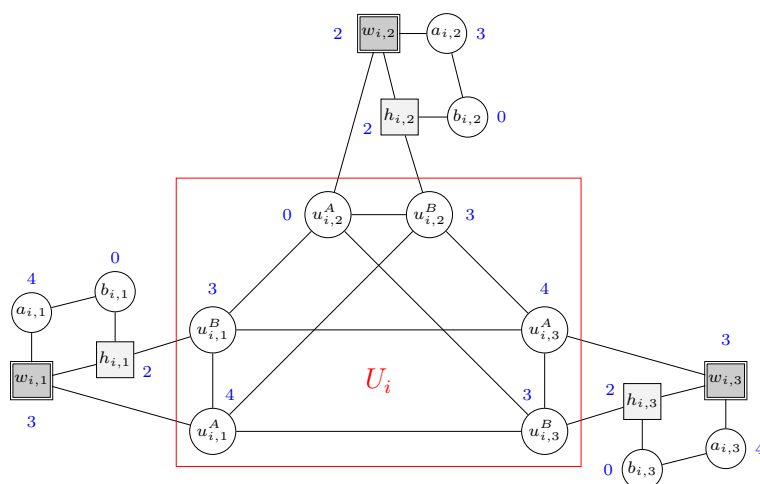

■ **Figure 7** Bipartite gadget of clause C_i . The blue numbers near the vertices are the activation times when $u_{i,2}^A$ is in the target set. The set U_i is inside the red square.

at most 2. Therefore, z is the unique vertex activated by S at time 5 and consequently all vertices of Y must be activated at time exactly 4.

With this, consider the following assignment. For every $u_{i,p}$ in S , for $p \in [3]$, assign true to the literal $\ell_{i,p}$. That is, if the literal $\ell_{i,p}$ is a positive literal, assign true to its variable; otherwise, assign false to its variable. This is a valid truth assignment, since all vertices of Y are activated at time 4 and consequently any two vertices of U representing complementary literals cannot be both in S . Moreover, this assignment satisfies all the clauses in \mathcal{C} , since S has at least one vertex in each set U_i and consequently the assignment satisfies at least one literal of every clause.

For time values $k > 5$, it suffices to include a new path P with $k - 6$ edges and $k - 5$ new vertices s_1, \dots, s_{k-5} and to add the edge zs_1 . Moreover create $k - 5$ new squared vertices s'_i and add the edge $s_i s'_i$ for $i \in [k - 5]$. As before, G has no vertex of degree 1. From this, it is easy to see that a target set S activates s_{k-5} at time at least k if and only if S activates z at time at least 5. ◀

4 TSS-time is FPT in graphs of bounded local treewidth

In this section we provide an FPT algorithm to solve the GTSS-TIME problem (so the TSS-TIME problem as well) in graphs of bounded local treewidth (Theorem 15). This result together the NP-completeness result of Theorem 9 will yield the complexity dichotomy proved in Theorem 16. We first need to introduce some notation and a slightly (more) generalized version of the GTSS-TIME problem.

Let G be a graph and τ be a generalized threshold function in G . Recall that $\tau^* = \max_{v \in V(G)} \tau(v)$. Given a subset $V_f \subseteq V(G)$ of *forced* vertices, we denote by $t_\tau(G, V_f)$ the maximum activation time $t_\tau(S_0)$ among all target sets S_0 of G such that $V_f \subseteq S_0$. Clearly, $t_\tau(G, \emptyset) = t_\tau(G)$, hence deciding whether $t_\tau(G, V_f) \geq k$, for a positive integer k , is equivalent to the GTSS-TIME problem if we consider the threshold of any vertex in V_f strictly greater than its degree, while the threshold of any other vertex is maintained. However, we still need this generalized version of the problem in this section, since we do not want the value of τ^* to increase when considering the auxiliary subproblems that we will define below.

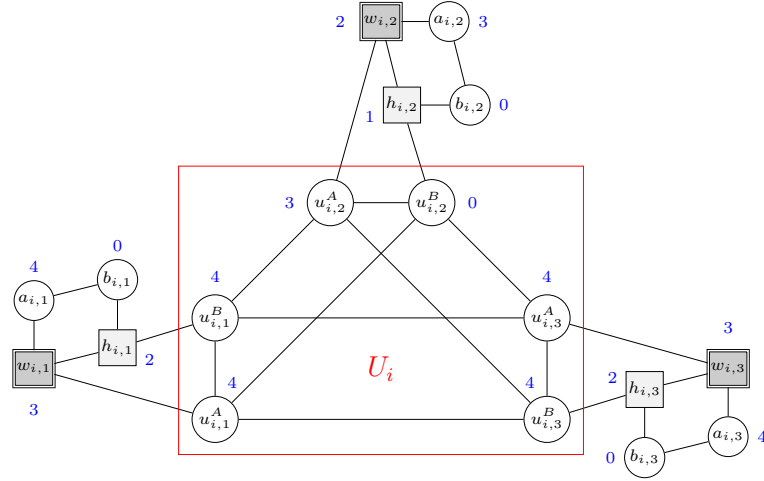

■ **Figure 8** Bipartite gadget of clause C_i . The blue numbers near the vertices are the activation times when $u_{i,2}^B$ is in the target set. The set U_i is inside the red square.

Before this, we show in the next lemma that deciding whether there exists a target set with activation time at least k is equivalent to the exact version.

► **Lemma 12.** *For every graph G , every generalized threshold function τ in G , every set $V_f \subseteq V(G)$, and every positive integer k , $t_\tau(G, V_f) \geq k$ if and only if there is target set $S_0 \subseteq V(G)$ with $V_f \subseteq S_0$ and such that $t_\tau(S_0) = k$. In particular, $t_\tau(G) \geq k$ if and only if there is target set $S_0 \subseteq V(G)$ such that $t_\tau(S_0) = k$.*

Proof. If there is target set $S_0 \subseteq V(G)$ with $V_f \subseteq S_0$ and such that $t_\tau(S_0) = k$, then by definition $t_\tau(G, V_f) \geq k$, so let us focus on the forward direction. Let S_0 be a target set of G with $V_f \subseteq S_0$ and such that $t_\tau(S_0) \geq k$, and let $S_0, S_1, S_2, \dots, S_t$ be the partition of $V(G)$ given by S_0 , where $t \geq k$. If $t = k$, then we are done. Otherwise, let $S'_0 = S_0 \cup S_1 \cup \dots \cup S_{t-k}$. It can be easily verified that S'_0 is a target set of G with $V_f \subseteq S'_0$ and such that $t_\tau(S'_0) = k$. ◀

We now define auxiliary graphs that will be used in the FPT algorithm of [Theorem 15](#). The crucial property of these auxiliary graphs is that they have diameter $\mathcal{O}(k)$, which will be exploited in order to bound their treewidth. Let G be a graph, let τ be a generalized threshold function in G , let $v \in V(G)$, and let k be a positive integer. We define the pair (G_k^v, τ_k^v) such that G_k^v is a graph and τ_k^v is a generalized threshold function in G_k^v , as follows. Let $G_k^v = G[N_k[v]]$, that is, the subgraph of G induced by the vertices at distance at most k from v in G (including v), and let τ_k^v be the restriction of τ to $N_k[v]$. Note that τ_k^v may not be a threshold function in G_k^v , even if τ is a threshold function in G , since the degree in G_k^v of the vertices at distance exactly k from v in G may have decreased, but τ_k^v is still a generalized threshold function in G_k^v such that $(\tau_k^v)^* \leq \tau^*$. In the next lemma we show that dealing with the auxiliary graphs G_k^v is enough in order to solve the GTSS-TIME problem.

► **Lemma 13.** *For every graph G , every generalized threshold function τ in G , and every positive integer k , $t_\tau(G) \geq k$ if and only if there exists a vertex $v \in V(G)$ such that $t_{\tau_k^v}(G_k^v, V_f) \geq k$, where V_f is the set of vertices at distance exactly k from v in G .*

Proof. Suppose first that $t_\tau(G) \geq k$. By [Lemma 12](#), there is target set $S_0 \subseteq V(G)$ such that $t_\tau(S_0) = k$. Let $V(G) = S_0 \uplus S_1 \uplus \dots \uplus S_k$ be the partition of $V(G)$ into k non-empty sets given by the activation process starting at S_0 , let v be any vertex in S_k , and let V_f be

the set of vertices at distance exactly k from v in G . We claim that $t_{\tau^v}(G_k^v, V_f) \geq k$. Let $S_0^v = (S_0 \cap N_{k-1}(v)) \cup V_f$. Since $V_f \subseteq S_0^v$, we just have to verify that S_0^v is a target set of G_k^v with $t_{\tau^v}(S_0^v) \geq k$. Since S_0 activates vertex v at time exactly k in G , $S_0 \cup \{u\}$ also activates vertex v at time exactly k for any vertex u at distance exactly k from v in G . Iterating this argument, it follows that $S_0 \cup V_f$ activates vertex v at time exactly k in G . Thus, S_0^v activates vertex v at time exactly k in G_k^v . As for the other vertices of G_k^v , since S_0 is a target set of G and $V_f \subseteq S_0^v$, it follows that S_0^v is indeed a target set of G_k^v containing V_f that activates v at time exactly k , and therefore $t_{\tau^v}(G_k^v, V_f) \geq k$.

Conversely, suppose that there exists $v \in V(G)$ such that $t_{\tau^v}(G_k^v, V_f) \geq k$, where V_f is the set of vertices at distance exactly k from v in G . Let S_0^v be a target set of G_k^v containing V_f such that $t_{\tau^v}(S_0^v) \geq k$. Let $S_0 = S_0^v \cup (V(G) \setminus N_k[v])$. That is, S_0 contains S_0^v and all vertices at distance at least $k+1$ from v in G . Since $V_f \subseteq S_0^v$, S_0 also contains all vertices at distance exactly k from v in G . We claim that S_0 is a target set of G with $t_\tau(S_0) \geq k$. The fact that S_0 is a target set of G follows from the hypothesis that S_0^v is a target set of G_k^v and the fact that S_0 contains all vertices at distance at least k from v in G . On the other hand, since $t_{\tau^v}(S_0^v) \geq k$, $V_f \subseteq S_0^v \subseteq S_0$, and no vertex in $V(G) \setminus N_k[v]$ has a neighbor in the set $N_{k-1}[v]$, it follows that $t_\tau(S_0) \geq k$, and therefore $t_\tau(G) \geq k$. \blacktriangleleft

The last ingredient that we need before proving [Theorem 15](#) is to show that deciding whether $t_\tau(G, V_f) \geq k$ can be expressed by an MSO_1 formula of appropriate length. Note that, in particular, this applies to deciding whether $t_\tau(G, \emptyset) = t_\tau(G) \geq k$, that is, to the GTSS-TIME problem.

► Lemma 14. *Given a graph G , a generalized threshold function τ in G , a subset $V_f \subseteq V(G)$, and a positive integer k , the problem of deciding whether $t_\tau(G, V_f) \geq k$ can be expressed by an MSO_1 formula ϕ whose length depends on k and τ^* .*

Proof. We may assume that G is given along with a partition of $V(G)$ according to V_f and the values of the generalized threshold function τ , namely $V(G) = V_f \uplus V_0 \uplus V_1 \uplus \dots \uplus V_{\tau^*}$, where $\tau^* = \max_{v \in V(G)} \tau(v)$ and, for $j \in [0, \tau^*]$, $V_j = \{v \in V(G) \setminus V_f \mid \tau(v) = j\}$. Note that V_f and the sets V_j may be empty. By [Lemma 12](#), (G, τ, k) is a yes-instance of GTSS-TIME if and only there exists a target set $S_0 \subseteq V(G)$ such that $t_\tau(G, \tau, S_0) = k$. The existence of such a set S_0 can be equivalently expressed as the existence of a partition $V(G) = S_0 \uplus S_1 \uplus \dots \uplus S_k$ into $k+1$ non-empty sets with $V_f \subseteq S_0$ and such that

- (i) for every $i \in [2, k]$ and every $j \in [0, \tau^*]$, every vertex in $S_i \cap V_j$ has strictly less than j neighbors in the set $\bigcup_{h=0}^{i-2} S_h$, and
- (ii) for every $i \in [1, k]$ and every $j \in [0, \tau^*]$, every vertex in $S_i \cap V_j$ has at least j neighbors in the set $\bigcup_{h=0}^{i-1} S_h$.

Let us argue that the above conditions can be indeed expressed by an MSO_1 formula ϕ whose length depends only on k and τ^* . First, note that the existence of $k+1$ pairwise disjoint vertex sets that form a partition of $V(G)$ with $V_f \subseteq S_0$ can be easily expressed in MSO_1 . On the other hand, in order to express condition (i) above, it suffices to quantify, for every $i \in [2, k]$, every $j \in [0, \tau^*]$, and every vertex $v \in S_i \cap V_j$, the non-existence of j neighbors of v in the set $\bigcup_{h=0}^{i-2} S_h$. Finally, as for condition (ii), it suffices to quantify, for every $i \in [1, k]$, every $j \in [0, \tau^*]$, and every vertex $v \in S_i \cap V_j$, the existence of j neighbors of v in the set $\bigcup_{h=0}^{i-1} S_h$. Clearly, the length of the obtained MSO_1 formula ϕ is bounded by a function of k and τ^* , and the lemma follows. \blacktriangleleft

We finally have all the ingredients to prove our FPT algorithm to solve the GTSS-TIME problem. For a graph class \mathcal{C} , we denote by $\text{GTSS-TIME}|_{\mathcal{C}}$ (resp. $\text{TSS-TIME}|_{\mathcal{C}}$) the restriction of the GTSS-TIME (resp. TSS-TIME) problem to input graphs G belonging to \mathcal{C} .

► **Theorem 15.** *If \mathcal{C} is a graph class of bounded local treewidth, then the $\text{GTSS-TIME}|_{\mathcal{C}}$ problem is FPT parameterized by k and τ^* .*

Proof. Let (G, τ, k) be an instance of GTSS-TIME where $G \in \mathcal{C}$, τ is a generalized threshold function in G , and k is a positive integer. Since \mathcal{C} has bounded local treewidth, there exists a function $f : \mathbb{N} \rightarrow \mathbb{N}$ such that, for every graph $G \in \mathcal{C}$, every vertex $v \in V(G)$ and every positive integer r , $\text{tw}(G[N_r[v]]) \leq f(r)$.

By Lemma 13, $t_{\tau}(G) \geq k$ if and only if there exists a vertex $v \in V(G)$ such that $t_{\tau^v}(G_k^v, V_f) \geq k$, where V_f is the set of vertices at distance exactly k from v in G . Based on this, for every vertex $v \in V(G)$, we generate in linear time the graph G_k^v , and it is enough to decide whether $t_{\tau^v}(G_k^v, V_f) \geq k$. Since $G_k^v = G[N_k[v]]$ and $G \in \mathcal{C}$, we have that $\text{tw}(G_k^v) \leq f(k)$. By Lemma 14, deciding whether $t_{\tau^v}(G_k^v, V_f) \geq k$ can be expressed by an MSO_1 (in particular, MSO) formula ϕ whose length depends only on k and $(\tau_k^v)^* \leq \tau^*$. Therefore, Theorem 3 implies that deciding whether $t_{\tau^v}(G_k^v, V_f) \geq k$ can be solved in time $g(k, \tau^*, \text{tw}(G_k^v)) \cdot n$ for some computable function g , where $n = |V(G)|$. Since $\text{tw}(G_k^v) \leq f(k)$, deciding whether $t_{\tau}(G) \geq k$ can be solved in time $h(k, \tau^*) \cdot n^2$ for some computable function $h : \mathbb{N}^2 \rightarrow \mathbb{N}$, and the theorem follows. ◀

As particular cases of Theorem 15, it follows that the $\text{GTSS-TIME}|_{\mathcal{C}}$ problem is FPT parameterized by k and τ^* when \mathcal{C} is the class of graphs of treewidth bounded by a constant, the class of graphs of maximum degree bounded by a constant, the class of planar graphs or, more generally, the class of graphs embeddable in a fixed surface (i.e., graphs of bounded genus).

With Theorem 9 and Theorem 15 at hand, the following theorem can be easily proved.

► **Theorem 16.** *Let \mathcal{C} be a minor-closed graph class. Then $\text{TSS-TIME}|_{\mathcal{C}}$ is*

- *FPT parameterized by k and τ^* , if \mathcal{C} has bounded local treewidth.*
- *NP-complete for every fixed $k \geq 4$ and $\tau^* = 2$, otherwise.*

Proof. Let \mathcal{C} be a minor-closed graph class. If \mathcal{C} has bounded local treewidth, the result follows from Theorem 15. Otherwise, Theorem 2 implies that \mathcal{C} contains all apex graphs, and by Theorem 9 the $\text{TSS-TIME}|_{\mathcal{C}}$ problem is NP-complete for every fixed $k \geq 4$ and $\tau^* = 2$. ◀

Note that, since both Theorem 9 and Theorem 15 apply to the GTSS-TIME problem, the same dichotomy above applies to the generalized version as well. Also, since $2\text{-NEIGHBOR BOOTSTRAP PERCOLATION-TIME}$ is a particular case of GTSS-TIME , Corollary 10 implies the same dichotomy for the former problem, with the constraint on τ^* being irrelevant.

5 Maximum TSS-time is linear-time solvable in trees

In this section, we obtain an $\mathcal{O}(n)$ -time algorithm and an $\mathcal{O}(n^2)$ -time algorithm for the maximization versions of TSS-TIME and GTSS-TIME in trees, respectively. That is, for the problems in which the objective is to compute the maximum activation time $t_{\tau}(T)$ of a given tree T and a (generalized) threshold function τ in T .

Let us begin with TSS-TIME . Given a tree T and a threshold function τ in T , we say that a vertex v is *saturated* if $\tau(v) = d(v)$; otherwise, it is *non-saturated*. Clearly, a saturated vertex v is activated if and only if it is in the target set or all its neighbors are activated. In other words, a saturated vertex outside the target set cannot help to activate other vertices.

Given a tree T and two adjacent vertices w and x , let $T(w, x)$ be the subtree containing x obtained from T by removing the edge wx . Also let $T[w, x]$ be the subtree obtained from $T(w, x)$ by adding vertex w and edge wx .

► **Lemma 17.** *Let $T = (V, E)$ be a tree with at least two vertices, τ be a threshold function in T , v be a leaf of T , and w be the only neighbor of v . There exists a proper subset $S \subsetneq V$ such that $v, w \notin S$ and $I(S) = S$, and $S \cup \{v\}$ is a target set (that is $H(S \cup \{v\}) = V$) which activates w at time 1.*

Proof. We prove the lemma by induction on the number n of vertices of T . If $n = 2$, T contains exactly the two vertices v and w and the edge vw . Moreover $\tau(v) = \tau(w) = 1$ (recall that $1 \leq \tau(x) \leq d(x)$ for every vertex x of T). Taking $S = \emptyset$, we are done, since $I(\emptyset) = \emptyset$ and $I(\{v\}) = \{v, w\} = V(T)$.

Now, fix $n > 2$, suppose that the lemma is true for every tree T with less than n vertices, and we will prove that the lemma is also true for trees on n vertices. Let v be any leaf of T and let w be the only neighbor of v . Since $n > 2$, $d(w) \geq 2$. Let $x_1, \dots, x_{d(w)-1}$ be the neighbors of w distinct from v . In the following, notice that the sets $[\tau(w) - 1]$ and $[\tau(w), d(w) - 1]$ may be empty.

We will construct a proper subset S of $V(T)$ satisfying the conditions of the lemma. Firstly let $S = \emptyset$. If $\tau(w) \geq 2$, add to S all the vertices in $T(w, x_i)$ for every $i \in [\tau(w) - 1]$. If $\tau(w) < d(w)$, fix $k \in [\tau(w), d(w) - 1]$. By the induction hypothesis, since the subtree $T[w, x_k]$ has less than n vertices and w is a leaf of $T[w, x_k]$, there exists a set S_k such that $w, x_k \notin S_k$, $I(S_k) = S_k$, and $H(S_k \cup \{w\}) \supseteq V(T[w, x_k])$. With this, add S_k to S for every $k \in [\tau(w), d(w) - 1]$.

By construction, we have that $v, w \notin S$. We first prove that $I(S) = S$ in T . Notice that the only neighbors of w in S are in $\{x_i \mid i \in [\tau(w) - 1]\}$, which cannot activate w , since its threshold is $\tau(w)$. Then, all the vertices in the subtrees $T(w, x_i)$ for all $i \in [\tau(w) - 1]$ together cannot activate w . Moreover, $\bigcup_{k=\tau(w)}^{d(w)-1} S_k$ (this set may be empty) cannot activate any vertex in $\{x_k \mid k \in [\tau(w), d(w) - 1]\}$, since $w, x_k \notin S_k$ and $I(S_k) = S_k$ for $k \in [\tau(w), d(w) - 1]$. Consequently, S cannot activate w and $I(S) = S$.

Now we prove that $H(S \cup \{v\}) = V(T)$, that is, that $S \cup \{v\}$ is a target set of T . Firstly notice that v together with all x_i 's with $i \in [\tau(w) - 1]$ activate w at time 1, since its threshold is $\tau(w)$. Moreover, recall that $H(S_k \cup \{w\}) = V(T[w, x_k])$. Therefore, all vertices in the subtrees $T[w, x_k]$ for $k \in [\tau(w), d(w) - 1]$ are activated in the process and consequently $H(S \cup \{v\}) = V(T)$. ◀

Figure 9 shows an example of the configuration considered in Lemma 17: a set S such that $S \cup \{v\}$ is a target set, but $I(S) = S$.

From Lemma 17, we obtain the following lemma for threshold functions in trees.

► **Lemma 18.** *Let $T = (V, E)$ be a tree with at least two vertices and τ be a threshold function in T . For any path $P = (v_0, v_1, \dots, v_p)$ with $p \geq 1$ in T with v_0 being a leaf and all internal vertices being non-saturated, there exists a target set S_P of T which contains v_0 and activates v_i at time i , for every $i \in [p]$.*

Proof. We prove the lemma by induction on the number p of edges in P . If $p = 1$, P has only two vertices v_0 and v_1 , where v_0 is a leaf and v_1 is the only neighbor of v_0 , and we are done by Lemma 17.

Now fix $p \geq 2$ and suppose that the lemma is true for every path with less than p edges. Let $P = (v_0, v_1, \dots, v_p)$ be a path with p edges such that v_0 is a leaf and all internal vertices are non-saturated. Let us prove that the lemma is true for P . Let T' be the subtree containing v_0 obtained from T by removing the edge $v_{p-1}v_p$. Since v_{p-1} is non-saturated, $\tau(v_{p-1})$ is strictly smaller than the degree of v_{p-1} in T , and consequently it is smaller than or equal to the degree of v_{p-1} in T' . With this, let τ' be the threshold function in T' such that $\tau'(u) = \tau(u)$ for every vertex of T' .

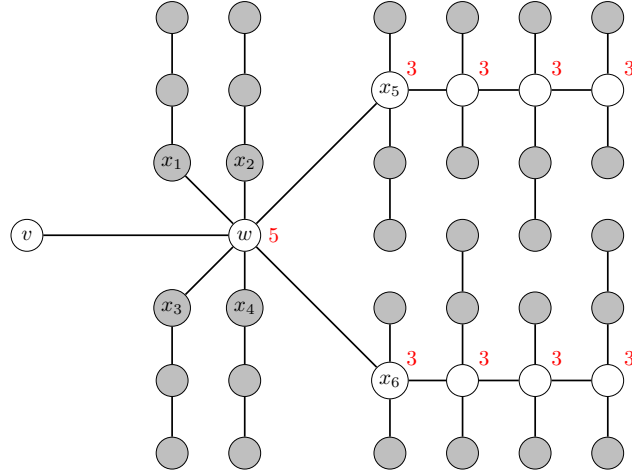

■ **Figure 9** An example of a tree T and vertices v and w as in the statement of Lemma 17. The vertices of S are shown in gray. The relevant thresholds are in red. Notice that $I(S) = S$ (i.e., S does not activate any vertex), but $S \cup \{v\}$ is a target set (i.e., $H(S \cup \{v\}) = V(T)$).

Since the path $P' = (v_0, v_1, \dots, v_{p-1})$ in T' (with threshold function τ') has less than p edges, we have by induction that there exists a target set S' of T' which contains v_0 and activates v_i at time i , for every $i \in [p-1]$.

Now let $T'' = T[v_{p-1}, v_p]$ and let τ'' be the threshold function in T'' such that $\tau''(v_{p-1}) = 1$ and $\tau''(u) = \tau(u)$ for every vertex $u \in V(T'') \setminus \{v_{p-1}\}$. Since v_{p-1} is a leaf of T'' and v_p is the only neighbor of v_{p-1} in T'' , we can apply Lemma 17 and obtain a vertex subset S'' in T'' such that $v_{p-1}, v_p \notin S''$ and S'' does not activate vertices in T'' , and such that $S'' \cup \{v_{p-1}\}$ is a target set of T'' which activates v_p at time 1.

With this, let $S_P = S' \cup S''$. By construction, we have that S_P contains v_0 and activates all vertices in T' , since it contains S' , activating v_i at time i for every $i \in [p-1]$. Finally, since S_P contains S'' and activates v_{p-1} at time $p-1$, we have that S_P also activates all vertices in T'' (and consequently S_P is a target set of T) and activates v_p at time p . ◀

Given a tree T and a threshold function τ in T , let $F_{T,\tau}$ be the forest obtained from T in the following way: first remove all saturated vertices, and then, for every saturated vertex v in T and every non-saturated neighbor w of v in T , create a new vertex v_w and add the edge $v_w w$ to $F_{T,\tau}$.

► **Theorem 19.** *For any tree T and threshold function τ in T , the maximum activation time $t_\tau(T)$ is the maximum diameter among the trees in the forest $F_{T,\tau}$. Consequently, TSS-TIME is linear-time solvable in trees.*

Proof. Consider a target set S of a tree T which activates a vertex v at time t . Then there exists a path $P = (v_0, v_1, \dots, v_{t-1}, v_t = v)$ in T of vertices activated by S at times $0, 1, \dots, t-1, t$, respectively. Since a saturated vertex is activated if it is in the target set or if all its neighbors are activated, all internal vertices in the path P are non-saturated.

Now consider a path $P = (v_0, v_1, \dots, v_t)$ such that all its internal vertices are non-saturated. Let $T' = T[v_0, v_1]$. Since v_0 is a leaf of T' , by Lemma 18 there exists a target set S' of T' which contains v_0 and activates v_i at time i for every $i \in [t]$. Let S be the set obtained from S' by adding all vertices in $V(T) \setminus V(T')$. Therefore, S is a target set of T which contains v_0 and activates v_i at time i for every $i \in [t]$.

Thus, T has maximum activation time at least t if and only if there exists a path P with t edges in T such that all its internal vertices are non-saturated. Then, by construction of $F_{T,\tau}$, the maximum activation time $t_\tau(T)$ is equal to the maximum diameter among the trees in the forest $F_{T,\tau}$. Since the diameter of a tree can be computed in linear time, and the forest $F_{T,\tau}$ can be clearly constructed in linear time, we have that TSS-TIME is linear-time solvable in trees. \blacktriangleleft

Let us now focus on the GTSS-TIME problem. Given a graph G , a generalized threshold function τ in G , a vertex subset $S_0 \subseteq V(G)$, and a vertex v of G , recall that $t_\tau(v, S_0)$ is the minimum integer k such that $v \in I^k(S_0)$, or $t_\tau(v, S_0) = \infty$ if $v \notin H(S_0)$. By applying the algorithm ACTIVATION-TIMES with input set S_0 , we have that $H(S_0)$ and $t_\tau(v, S_0)$ for every vertex v can be computed in time $\mathcal{O}(m+n)$.

We first prove the auxiliary lemma below. Let in this section V_f be the set of *forced* vertices by the threshold function, that is, the set of vertices u of T with $\tau(u) > d(u)$.

► **Lemma 20.** *Let T be a tree and τ be a generalized threshold function in T . Let $S_0 \supseteq V_f$. For every vertex $v \in H(S_0)$, there exists a target set $S_v \supseteq S_0$ such that $t_\tau(v, S_v) = t_\tau(v, S_0)$.*

Proof. Initially let $S_v = S_0$. If S_v is a target set, we are done. Otherwise, we iteratively apply the following procedure:

(✕) Let T_v be the maximal subtree of T containing v and all vertices in $H(S_v)$. Let u be any vertex of T_v with a neighbor w outside T_v . Let T_w be the maximal subtree of $T[u, w]$ containing u and w with no vertex in $H(S_v)$ other than u . Also let τ_w be such that $\tau_w(u) = 1$, $\tau_w(w) = \tau(w) - |N(w) \cap H(S_v)| + 1$, and $\tau_w(x) = \tau(x) - |N(x) \cap H(S_v)|$ for every vertex x of T_w , except u and w . Notice that τ_w is a threshold function of T_w and u is a leaf of T_w . Then, applying Lemma 17, we have that there exists a set S_w in T_w that activates no vertex in T and such that $S_w \cup \{u\}$ is a target set of T_w . Add S_w to S_v . Notice that $t_\tau(v, S_v) = t_\tau(v, S_0)$.

Repeating (✕) until $H(S_v) = V(T)$, we obtain a target set S_v such that $t_\tau(v, S_v) = t_\tau(v, S_0)$, and the lemma follows. \blacktriangleleft

We now explain how to compute $t_\tau(T)$ in time $\mathcal{O}(n^2)$ for a given pair (T, τ) . For this, we define, for every vertex v of T , $t_\tau(v)$ as the maximum $t_\tau(v, S_0)$ among all target sets S_0 of T . Start by computing $H(V_f)$ and compute the time $t_\tau(v) = t_\tau(v, V_f)$ for every $v \in H(V_f)$. We define the *beginning time* $b(v)$ of every vertex $v \in V(T) \setminus V_f$ as the maximum $t_\tau(w)$ among all neighbors w of v in $H(V_f)$, if there is one. Otherwise, let $b(v) = 0$.

As before, we say that a vertex v is *saturated* if $\tau(v) = d(v)$; otherwise it is *non-saturated*. As before, a saturated vertex is activated if and only if it is in the target set or if all its neighbors are activated. In other words, a saturated vertex outside the target set cannot help to activate other vertices.

A *non-saturated path* in the tree T is a path such that all its vertices are non-saturated (including the endpoints) and are outside $H(V_f)$. Here we allow paths with only one vertex (and no edge) from a vertex v to itself.

► **Lemma 21.** *Let T be a tree, τ be a generalized threshold function in T , and $v \in V(T)$. Let V_f be the set of vertices u of T with $\tau(u) > d(u)$. If $v \in H(V_f)$, then $t_\tau(v) = t_\tau(v, V_f)$. If v is non-saturated outside $H(V_f)$, then $t_\tau(v) = \max\{|P| + b(u) : P \text{ is a non-saturated path with an endpoint in } v, \text{ where } u \text{ is the other endpoint}\}$. If v is saturated outside $H(V_f)$, then $t_\tau(v) = 1 + \max\{t_\tau(u)\}$ among all non-saturated neighbors u of v , if there is one; otherwise $t_\tau(v) = 1$.*

Proof. Let v be a vertex of T . Suppose first that $v \in H(V_f)$. From Lemma 20, there exists a target set S_v such that $t_\tau(v, S_v) = t_\tau(v, V_f)$. Therefore, $t_\tau(v) \geq t_\tau(v, V_f)$. Moreover, since the vertices of V_f must be in the target set S'_v with $t_\tau(v, S'_v) = t_\tau(v)$, then $t_\tau(v) = t_\tau(v, S'_v) \leq t_\tau(v, V_f)$, and we are done.

Now suppose that $v \notin H(V_f)$ and v is saturated. If all neighbors of v are saturated, then $t_\tau(v) = 1$, since all its neighbors must be in the target set (otherwise v must be in the target set) and $V(T) \setminus \{v\}$ is a target set activating v at time 1. Moreover, if v is saturated and has at least one non-saturated neighbor, then $t_\tau(v) = 1 + \max\{t_\tau(u) : u \text{ is a non-saturated neighbor of } v\}$, since v cannot be activated before its neighbors (unless it is in the target set).

Finally, consider a non-saturated vertex v . Consider a target set S_0 which activates v at time t . We want to show that there exists a path P of non-saturated vertices such that $t = b(u) + |P|$, where u and v are the endpoints of P . First notice that there exists a path $P' = (u_0, u_1, u_2, \dots, u_{t-1}, v)$ in the tree T whose vertices are activated by S_0 at times $0, 1, 2, \dots, t-1, t$, respectively. Since vertices with $\tau(v) \geq d(v)$ cannot help to activate other vertices at time greater than 1, all vertices in the path P' , except u_0 , are non-saturated. We may assume that there exists $0 \leq k < t$ such that $u_1, \dots, u_k \in H(V_f)$ and $u_{k+1}, \dots, u_{t-1} \notin H(V_f)$. This is because every vertex of $H(V_f)$ with activation time $k+1$ was activated by a vertex of $H(V_f)$ with activation time k . Therefore $b(u_{k+1}) \geq t_\tau(u_k) = k$. The subpath $P = (u_{k+1}, \dots, u_{t-1}, v)$ of P' is a non-saturated path and has size $|P| = t - k$. Then the activation time of v in the process of the target set S_0 is equal to $t = k + (t - k) = b(u) + |P|$, where $u = u_{k+1}$ is the endpoint of P distinct from v .

Now consider a non-saturated path $P = (u_1, \dots, u_{\ell-1}, v)$ with size $|P| = \ell$. Recall that, by definition, P has no vertex in $H(V_f)$. We want to show that there exists a target set S_0 which activates v at time $b(u_1) + \ell$. Initially let $S_0 = V_f$. Since u_1 is non-saturated, we can add to S_0 $\tau(u_1) - |N(u_1) \cap H(S_0)|$ neighbors of u_1 outside $H(S_0)$ distinct from u_2 . With this, S_0 activates u_1 at time $b(u_1) + 1$. Again, since u_2 is non-saturated, we can add to S_0 $\tau(u_2) - |N(u_2) \cap H(S_0)|$ neighbors of u_2 outside $H(S_0)$ distinct from u_3 . With this, S_0 activates u_2 at time $b(u_1) + 2$. Following these arguments, we obtain a set S_0 which activates v at time $b(u_1) + \ell$. From Lemma 20, there exists a target set $S_v \supset S_0$ which activates u_ℓ at time $b(u_1) + \ell$, and we are done. \blacktriangleleft

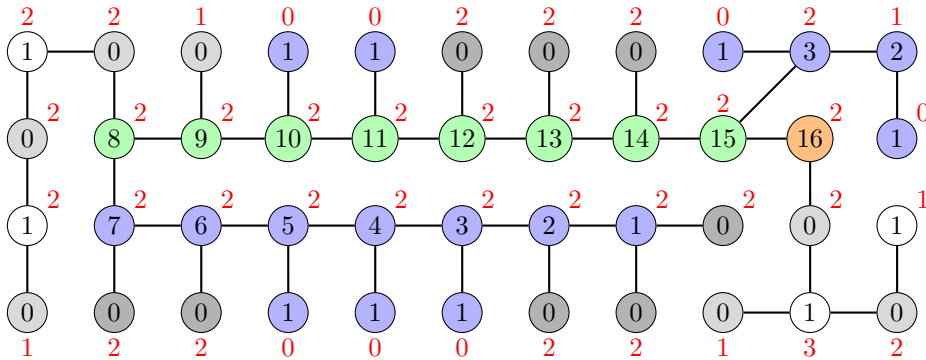

■ **Figure 10** A tree G with maximum activation time 16. The thresholds are in red, V_f is in dark gray, and $H(V_f) \setminus S_0$ is in blue. A maximum path of non-saturated vertices is in green. The vertex with maximum activation time 16 is in orange (notice that it is saturated). The numbers inside the vertices are their activation times. The target set S_0 with maximum activation time is in dark gray and light gray (vertices with activation time 0).

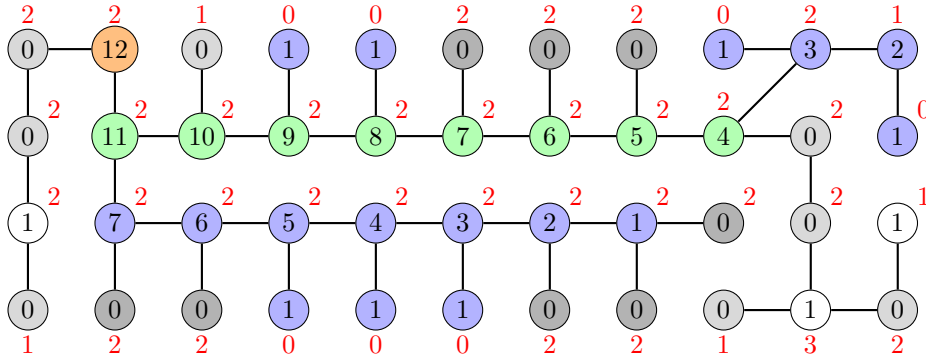

■ **Figure 11** Another target set of the same tree of Figure 10 (with time 12). The thresholds are in red, V_f is in dark gray, and $H(V_f) \setminus S_0$ is in blue. A maximum path of non-saturated vertices is in green. The vertex with time 12 is in orange (notice that it is saturated). The numbers inside the vertices are their activation times. The target set S_0 is in dark gray and light gray (vertices with time 0).

Figure 10 and Figure 11 show an example for the same tree T . In both figures, the dark gray vertices are the vertices of V_f (that is, vertices v with $\tau(v) > d(v)$) and the blue vertices are the vertices in $H(V_f) \setminus V_f$. Let u and v be the vertices with labels 8 and 15 in Figure 10, respectively. Notice that all 8 vertices in the path between u and v (green in both figures) are non-saturated. In both figures, The numbers inside the dark gray or blue vertices are the values of $t_\tau(w)$ of the vertices in $H(V_f)$. In this example, we have that $b(u) = 7$ and $b(v) = 3$. Moreover, $t_\tau(u) = 3 + 8 = 11$ and $t_\tau(v) = 7 + 8 = 15$. The maximum times 16 and 12 in Figure 10 and Figure 11, respectively, are achieved at saturated vertices. The maximum time $t_\tau(T)$ is 16, obtained by the target set of Figure 10. Figure 12 shows an example where the maximum time is achieved at a vertex of $H(V_f)$.

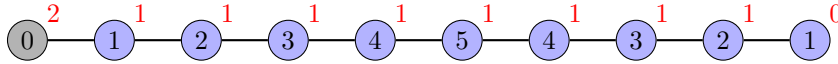

■ **Figure 12** Example with maximum activation time $t(G) = 5$. All vertices belong to $H(B_0)$. The target set is B_0 (only the vertex in dark gray). The thresholds are in red. The numbers inside the vertices are their activation times.

► **Theorem 22.** *Let T be a tree and τ be a generalized threshold function in T . Then, $t_\tau(T) = \max\{t_\tau(v) \mid v \in V(T)\}$. Consequently, GTSS-TIME is $\mathcal{O}(n^2)$ -time solvable in trees.*

Proof. Clearly $t_\tau(T) = \max\{t_\tau(v) \mid v \in V(T)\}$, since the maximum activation time must be achieved at some vertex. In order to compute $t_\tau(T)$, we have to compute $H(V_f)$ and $b(v)$ for every vertex v of T , which can be done in $\mathcal{O}(n)$ -time by the algorithm ACTIVATION-TIMES. With this, we have computed $t_\tau(v)$ for every vertex $v \in H(V_f)$. Let v be a non-saturated vertex outside $H(V_f)$. We can now compute a maximum non-saturated path P with an endpoint in v in $\mathcal{O}(n)$ -time, by a breadth-first search over non-saturated vertices outside $H(V_f)$. Thus, we can compute $t_\tau(v)$ for every non-saturated vertex outside $H(V_f)$ in time $\mathcal{O}(n^2)$. For saturated vertices v , we can compute $t_\tau(v)$ by searching locally within its neighborhood. ◀

One interesting observation is that, in Theorem 19, the threshold values are not important, but only whether a vertex is saturated or not. However, in Theorem 22, the threshold values are important, since the beginning set $H(V_f)$ depends on these values.

6 Further research

We introduced the TARGET SET SELECTION-TIME (TSS-TIME) problem and studied its computational complexity, as well as for its generalized version (GTSS-TIME), obtaining both positive and negative results. A number of interesting questions remain open. In particular, is the value of k in our NP-hardness results tight? Namely, $k = 4$ in [Theorem 8](#) and [Theorem 9](#), and $k = 5$ in [Theorem 11](#). For the 2-NEIGHBOR BOOTSTRAP PERCOLATION-TIME problem, non-trivial arguments were needed in order to establish such dichotomies [[48](#)], which do not seem to be easily generalizable to our problem.

Our main result ([Theorem 16](#)) is a complexity dichotomy for the TSS-TIME problem in minor-closed graph classes, as well as for its generalized version. Within minor-closed graph classes of bounded local treewidth (for which we know that the TSS-TIME problem is FPT with parameters k and τ^*), it would be very interesting to obtain an additional dichotomy distinguishing between the polynomial-time solvable cases (such as trees, cf. [Theorem 19](#)) and the NP-complete ones (such as planar graphs, cf. [Corollary 7](#)). Another natural research direction is to obtain a complexity dichotomy including also graph classes that are not minor-closed. In the proof of our dichotomy ([Theorem 16](#)), we crucially use [Theorem 2](#), which only applies to minor-closed graph classes.

As an ingredient in our complexity dichotomy, we proved in [Theorem 15](#) that, if \mathcal{C} is a graph class of bounded local treewidth, then the GTSS-TIME problem restricted to input graphs in \mathcal{C} is FPT parameterized by k and τ^* . Our algorithm uses Courcelle’s Theorem [[27](#)] as a black box, and therefore we did not focus on optimizing the dependence on k and τ^* of our algorithm. Note that, by [Corollary 7](#), the TSS-TIME problem is NP-hard in graphs with maximum degree Δ for any fixed $\Delta \geq 4$ and $k = \Theta(\log n)$, even if all thresholds are equal to 2. Since graphs of bounded maximum degree have bounded local treewidth, this implies that, even if τ^* is bounded by a constant, the dependence on k of an FPT algorithm cannot be of the form $2^{\mathcal{O}(k)}$ unless $P = NP$. Also, what about the hardness of the TSS-TIME problem in graphs of bounded local treewidth if k is a constant, and τ^* may depend on n ? This would be the “dual” scenario of the one discussed above for planar graphs and graphs of bounded maximum degree, that is, τ^* constant and k depending on n .

We presented algorithms in time $\mathcal{O}(n)$ and $\mathcal{O}(n^2)$ to find a target set with maximum activation time in a tree for threshold functions and generalized threshold functions, respectively. Obtaining a linear-time algorithm for the latter problem in trees remain open. Finally, can we obtain polynomial-time algorithms in graph classes other than trees? In particular, what about cactus graphs or cographs? Even cliques do not seem to be completely trivial.

References

- 1 Eyal Ackerman, Oren Ben-Zwi, and Guy Wolfowitz. Combinatorial model and bounds for target set selection. *Theoretical Computer Science*, 411:4017–4022, 2010. doi:10.1016/j.tcs.2010.08.021.
- 2 Hamed Amini. Bootstrap percolation in living neural networks. *Journal of Statistical Physics*, 141(3):459–475, 2010. doi:10.1007/s10955-010-0056-z.
- 3 József Balogh and Béla Bollobás. Bootstrap percolation on the hypercube. *Probability Theory and Related Fields*, 134(4):624–648, 2006. doi:10.1007/s00440-005-0451-6.
- 4 József Balogh, Béla Bollobás, Hugo Duminil-Copin, and Robert Morris. The sharp threshold for bootstrap percolation in all dimensions. *Transactions of the American Mathematical Society*, 364(5):2667–2701, 2012. URL: www.jstor.org/stable/41524940.
- 5 József Balogh, Béla Bollobás, and Robert Morris. Bootstrap percolation in three dimensions. *The Annals of Probability*, 37(4):1329–1380, 2009. doi:10.1214/08-AOP433.

- 6 József Balogh, Béla Bollobás, and Robert Morris. Bootstrap Percolation in High Dimensions. *Combinatorics, Probability and Computing*, 19(5-6):643–692, 2010. doi:10.1017/S0963548310000271.
- 7 Suman Banerjee, Rogers Mathew, and Fahad Panolan. Target set selection on graphs of bounded vertex cover number. *CoRR*, abs/1812.01482, 2018. URL: <http://arxiv.org/abs/1812.01482>.
- 8 Rommel M. Barbosa, Erika M. M. Coelho, Mitre C. Dourado, Dieter Rautenbach, and Jayme L. Szwarcfiter. On the Carathéodory Number for the Convexity of Paths of Order Three. *SIAM Journal on Discrete Mathematics*, 26(3):929–939, 2012. doi:10.1137/110828678.
- 9 Cristina Bazgan, Morgan Chopin, André Nichterlein, and Florian Sikora. Parameterized inapproximability of target set selection and generalizations. *Computability*, 3:135–145, 2014. doi:10.3233/COM-140030.
- 10 Oren Ben-Zwi, Danny Hermelin, Daniel Lokshtanov, and Ilan Newman. Treewidth governs the complexity of target set selection. *Discrete Optimization*, 8:87–96, 2011. doi:10.1016/j.disopt.2010.09.007.
- 11 Fabrício Benevides, Victor Campos, Mitre C. Dourado, Rudini Sampaio, and Ana Silva. The maximum time of 2-neighbour bootstrap percolation: algorithmic aspects. *European Journal of Combinatorics*, 48:88–99, 2015. doi:10.1016/j.ejc.2015.02.012.
- 12 Fabrício Benevides, Victor Campos, Mitre C. Dourado, Rudini M. Sampaio, and Ana Silva. The maximum infection time in the geodesic and monophonic convexities. *Theoretical Computer Science*, 609:287–295, 2016. doi:10.1016/j.tcs.2015.10.009.
- 13 Fabrício Benevides and Michał Przykucki. On slowly percolating sets of minimal size in bootstrap percolation. *The Electronic Journal of Combinatorics*, 20(2):1–20, 2013. doi:10.37236/2542.
- 14 Fabrício Benevides and Michał Przykucki. Maximum Percolation Time in Two-Dimensional Bootstrap Percolation. *SIAM Journal on Discrete Mathematics*, 29(1):224–251, 2015. doi:10.1137/130941584.
- 15 Stéphane Bessy, Stefan Ehard, Lucia D. Penso, and Dieter Rautenbach. Dynamic monopolies for interval graphs with bounded thresholds. *Discrete Applied Mathematics*, 260:256–261, 2019. doi:10.1016/j.dam.2019.01.022.
- 16 Letícia R. Bueno, Lucia D. Penso, Fábio Protti, Victor R. Ramos, Dieter Rautenbach, and Uéverton S. Souza. On the hardness of finding the geodetic number of a subcubic graph. *Information Processing Letters*, 135:22–27, 2018. doi:10.1016/j.ipl.2018.02.012.
- 17 Carmen C. Centeno, Mitre C. Dourado, Lucia D. Penso, Dieter Rautenbach, and Jayme L. Szwarcfiter. Irreversible conversion of graphs. *Theoretical Computer Science*, 412(29):3693–3700, 2011. doi:10.1016/j.tcs.2011.03.029.
- 18 John Chalupa, Paul Larry Leath, and Gary Robert Reich. Bootstrap percolation on a Bethe lattice. *Journal of Physics C: Solid State Physics*, 12(1):31–35, 1979. doi:10.1088/0022-3719/12/1/008.
- 19 Ching-Lueh Chang and Yuh-Dauh Lyuu. Bounding the sizes of dynamic monopolies and convergent sets for threshold-based cascades. *Theoretical Computer Science*, 468:37–49, 2013. doi:10.1016/j.tcs.2012.11.016.
- 20 Ning Chen. On the Approximability of Influence in Social Networks. *SIAM Journal on Discrete Mathematics*, 23(3):1400–1415, 2009. doi:10.1137/08073617X.
- 21 Chun-Ying Chiang, Liang-Hao Huang, Bo-Jr Li, Jiaojiao Wu, and Hong-Gwa Yeh. Some results on the target set selection problem. *Journal of Combinatorial Optimization*, 25(4):702–715, 2013. doi:10.1007/s10878-012-9518-3.
- 22 Morgan Chopin, André Nichterlein, Rolf Niedermeier, and Mathias Weller. Constant thresholds can make target set selection tractable. *Theory of Computing Systems*, 55(1):61–83, 2014. doi:10.1007/s00224-013-9499-3.
- 23 Ferdinando Cicalese, Gennaro Cordasco, Luisa Gargano, Martin Milanič, Joseph Peters, and Ugo Vaccaro. Spread of influence in weighted networks under time and budget constraints.

- Theoretical Computer Science*, 586:40–58, 2015. Fun with Algorithms. doi:10.1016/j.tcs.2015.02.032.
- 24 Ferdinando Cicalese, Gennaro Cordasco, Luisa Gargano, Martin Milanič, and Ugo Vaccaro. Latency-bounded target set selection in social networks. *Theoretical Computer Science*, 535:1–15, 2014. doi:10.1016/j.tcs.2014.02.027.
 - 25 Gennaro Cordasco, Luisa Gargano, Marco Mecchia, Adele A. Rescigno, and Ugo Vaccaro. Discovering small target sets in social networks: a fast and effective algorithm. *Algorithmica*, 80(6):1804–1833, 2018. doi:10.1007/s00453-017-0390-5.
 - 26 Eurinaldo R. Costa, Mitre C. Dourado, and Rudini M. Sampaio. Inapproximability results related to monophonic convexity. *Discrete Applied Mathematics*, 197:70–74, 2015. doi:10.1016/j.dam.2014.09.012.
 - 27 Bruno Courcelle. The monadic second-order logic of graphs. I. Recognizable sets of finite graphs. *Information and Computation*, 85(1):12–75, 1990.
 - 28 Marek Cygan, Fedor V. Fomin, Lukasz Kowalik, Daniel Lokshtanov, Dániel Marx, Marcin Pilipczuk, Michal Pilipczuk, and Saket Saurabh. *Parameterized Algorithms*. Springer, 2015. doi:10.1007/978-3-319-21275-3.
 - 29 Elias Dahlhaus, David S. Johnson, Christos H. Papadimitriou, Paul D. Seymour, and Mihalis Yannakakis. The Complexity of Multiterminal Cuts. *SIAM Journal on Computing*, 23(4):864–894, 1994. doi:10.1137/S0097539792225297.
 - 30 Reinhard Diestel. *Graph Theory, 4th Edition*, volume 173 of *Graduate texts in mathematics*. Springer, 2012. URL: <https://dblp.org/rec/books/daglib/0030488.bib>.
 - 31 Mitre C. Dourado, Lucia D. Penso, and Dieter Rautenbach. Geodetic convexity parameters for $(q, q - 4)$ -graphs. *Discrete Applied Mathematics*, 223:64–71, 2017. doi:10.1016/j.dam.2017.01.023.
 - 32 Rodney G. Downey and Michael R. Fellows. *Fundamentals of Parameterized Complexity*. Texts in Computer Science. Springer, 2013. doi:10.1007/978-1-4471-5559-1.
 - 33 Pierre Duchet. Convex sets in graphs, II. Minimal path convexity. *Journal of Combinatorial Theory, Series B*, 44(3):307–316, 1988. doi:10.1016/0095-8956(88)90039-1.
 - 34 Pavel Dvořák, Dusan Knop, and Tomáš Toufar. Target Set Selection in Dense Graph Classes. In Wen-Lian Hsu, Der-Tsai Lee, and Chung-Shou Liao, editors, *29th International Symposium on Algorithms and Computation (ISAAC 2018)*, volume 123 of *Leibniz International Proceedings in Informatics (LIPIcs)*, pages 18:1–18:13, Dagstuhl, Germany, 2018. Schloss Dagstuhl–Leibniz-Zentrum fuer Informatik. doi:10.4230/LIPIcs.ISAAC.2018.18.
 - 35 Stefan Ehard and Dieter Rautenbach. On some tractable and hard instances for partial incentives and target set selection. *Discrete Optimization*, 34:100547, 2019. doi:10.1016/j.disopt.2019.05.004.
 - 36 David Eppstein. Diameter and treewidth in minor-closed graph families. *Algorithmica*, 27(3):275–291, 2000. doi:10.1007/s004530010020.
 - 37 Paul Erdős, Edrita Fried, András Hajnal, and Eric C. Milner. Some remarks on simple tournaments. *Algebra Universalis*, 2:238–245, 1972. doi:10.1007/BF02945032.
 - 38 Martin Farber and Robert E. Jamison. Convexity in graphs and hypergraphs. *SIAM Journal on Algebraic Discrete Methods*, 7(3):433–444, 1986. doi:10.1137/0607049.
 - 39 Martin Grohe. Local Tree-Width, Excluded Minors, and Approximation Algorithms. *Combinatorica*, 23(4):613–632, 2003. doi:10.1007/s00493-003-0037-9.
 - 40 Frank Harary and Juhani Nieminen. Convexity in graphs. *Journal of Differential Geometry*, 16(2):185–190, 1981.
 - 41 Tim A. Hartmann. Target Set Selection Parameterized by Clique-Width and Maximum Threshold. In *Proc. of the 44th International Conference on Current Trends in Theory and Practice of Computer Science (SOFSEM)*, volume 10706 of *LNCS*, pages 137–149, 2018. doi:10.1007/978-3-319-73117-9_10.

- 42 Alexander E. Holroyd. Sharp metastability threshold for two-dimensional bootstrap percolation. *Probability Theory and Related Fields*, 125(2):195–224, 2003. doi:10.1007/s00440-002-0239-x.
- 43 Paul A. Dreyer Jr. and Fred S. Roberts. Irreversible k -threshold processes: Graph-theoretical threshold models of the spread of disease and of opinion. *Discrete Applied Mathematics*, 157(7):1615–1627, 2009. doi:10.1016/j.dam.2008.09.012.
- 44 David Kempe, Jon M. Kleinberg, and Éva Tardos. Maximizing the Spread of Influence through a Social Network. In *Proc. of the 9th ACM SIGKDD International Conference on Knowledge Discovery and Data Mining*, pages 137–146, 2003. doi:10.1145/956750.956769.
- 45 David Kempe, Jon M. Kleinberg, and Éva Tardos. Maximizing the Spread of Influence through a Social Network. *Theory of Computing*, 11:105–147, 2015. doi:10.4086/toc.2015.v011a004.
- 46 Kaveh Khoshkhan, Hossein Soltani, and Manouchehr Zaker. Dynamic monopolies in directed graphs: The spread of unilateral influence in social networks. *Discrete Applied Mathematics*, 171:81–89, 1986. doi:10.1016/j.dam.2014.02.006.
- 47 Jan Kynčl, Bernard Lidický, and Tomáš Vyskočil. Irreversible 2-conversion set in graphs of bounded degree. *Discrete Mathematics & Theoretical Computer Science*, 19(3):81–89, 2017. doi:10.23638/DMTCS-19-3-5.
- 48 Thiago Braga Marcilon and Rudini Sampaio. The maximum time of 2-Neighbor Bootstrap Percolation: Complexity results. *Theoretical Computer Science*, 708:1–17, 2018. doi:10.1016/j.tcs.2017.10.014.
- 49 Thiago Braga Marcilon and Rudini M. Sampaio. The maximum infection time of the P_3 convexity in graphs with bounded maximum degree. *Discrete Applied Mathematics*, 251:245–257, 2018. doi:10.1016/j.dam.2018.05.053.
- 50 Thiago Braga Marcilon and Rudini Menezes Sampaio. The P_3 infection time is $W[1]$ -hard parameterized by the treewidth. *Information Processing Letters*, 132:55–61, 2018. doi:10.1016/j.ipl.2017.12.006.
- 51 Robert Morris. Minimal percolating sets in bootstrap percolation. *The Electronic Journal of Combinatorics*, 16(R2):1–20, 2003.
- 52 André Nichterlein, Rolf Niedermeier, Johannes Uhlmann, and Mathias Weller. On tractable cases of target set selection. *Social Network Analysis and Mining*, 3(2):233–256, 2013. doi:10.1007/s13278-012-0067-7.
- 53 Michał Przykucki. Maximal Percolation Time in Hypercubes Under 2-Bootstrap Percolation. *The Electronic Journal of Combinatorics*, 19(2):1–13, 2012. doi:10.37236/2412.
- 54 Eric Riedl. Largest Minimal Percolating Sets in Hypercubes under 2-Bootstrap Percolation. *The Electronic Journal of Combinatorics*, 17(R80):1–13, 2010. doi:10.37236/352.
- 55 Hossein Soltani and Babak Moazzez. A polyhedral study of dynamic monopolies. *Annals of Operations Research*, 279(1-2):71–87, 2019. doi:10.1007/s10479-018-3107-5.
- 56 Asahi Takaoka and Shuichi Ueno. A Note on Irreversible 2-Conversion Sets in Subcubic Graphs. *IEICE Transactions on Information and Systems*, E98.D(8):1589–1591, 2015. doi:10.1587/transinf.2015EDL8021.
- 57 Marcel L. J. van de Vel. *Theory of convex structures*, volume 50. Elsevier, 1993.
- 58 Manouchehr Zaker. On dynamic monopolies of graphs with general thresholds. *Discrete Mathematics*, 312(6):1136–1143, 2012. doi:10.1016/j.disc.2011.11.038.