



**HAL**  
open science

## **A Cable Driven Parallel Robot with a Modular End Effector for the Installation of Curtain Wall Modules**

Kepa Iturralde, Malte Feucht, Rongbo Hu, Wen Pan, Marcel Schlandt, Thomas Linner, Thomas Bock, Jean-Baptiste Izard, Ibon Eskudero, Mariola Rodriguez, et al.

► **To cite this version:**

Kepa Iturralde, Malte Feucht, Rongbo Hu, Wen Pan, Marcel Schlandt, et al.. A Cable Driven Parallel Robot with a Modular End Effector for the Installation of Curtain Wall Modules. ISARC 2020 - 37th International Symposium on Automation and Robotics in Construction, Oct 2020, Kitakyushu, Japan. pp.1472-1479, 10.22260/ISARC2020/0204 . lirmm-04041835

**HAL Id: lirmm-04041835**

**<https://hal-lirmm.ccsd.cnrs.fr/lirmm-04041835>**

Submitted on 22 Mar 2023

**HAL** is a multi-disciplinary open access archive for the deposit and dissemination of scientific research documents, whether they are published or not. The documents may come from teaching and research institutions in France or abroad, or from public or private research centers.

L'archive ouverte pluridisciplinaire **HAL**, est destinée au dépôt et à la diffusion de documents scientifiques de niveau recherche, publiés ou non, émanant des établissements d'enseignement et de recherche français ou étrangers, des laboratoires publics ou privés.

# A Cable Driven Parallel Robot with a Modular End Effector for the installation of Curtain Wall Modules

K. Iturralde<sup>1a</sup>, M. Feucht<sup>a</sup>, R. Hu<sup>a</sup>, W. Pan<sup>a</sup>, M. Schlandt<sup>a</sup>, T. Linner<sup>a</sup>, T. Bock<sup>a</sup>,  
J.-B. Izard<sup>b</sup>, I. Eskudero<sup>b</sup>, M. Rodriguez<sup>b</sup>, J. Gorrotxategi<sup>b</sup>, J. Astudillo<sup>c</sup>, J. Cavalcanti<sup>c</sup>,  
M. Gouttefarde<sup>c</sup>, M. Fabritius<sup>d</sup>, C. Martin<sup>d</sup>, T. Henninge<sup>e</sup>, S. M. Normes<sup>e</sup>, Y. Jacobsen<sup>e</sup>,  
A. Pracucci<sup>f</sup>, J. Cañada<sup>f</sup>, J.D. Jimenez-Vicaria<sup>h</sup>, C. Paulotto<sup>h</sup>, R. Alonso<sup>i</sup>, L. Elia<sup>i</sup>

<sup>a</sup> Chair of Building Realization and Robotics, Technical University of Munich, Germany

<sup>b</sup>TECNALIA, Basque Research and Technology Alliance (BRTA), Spain

<sup>c</sup>LIRMM, CNRS, France

<sup>d</sup>IPA, Fraunhofer, Germany

<sup>e</sup>nLink, Norway

<sup>f</sup>Focchi Spa, Italy

<sup>g</sup>Vicinay-Cemvisa, Spain,

<sup>h</sup>Acciona, Spain,

<sup>i</sup>R2M Solution, United Kingdom

E-mail: [kepa.iturralde@br2.ar.tum.de](mailto:kepa.iturralde@br2.ar.tum.de)

## Abstract –

The installation of curtain wall modules (CWM) is a risky activity carried out in heights and often under unfavorable weather conditions. CWM are heavy prefabricated walls that are lifted normally with cinches and cranes. High stability is needed while positioning in order not to damage the fragile CWM. Moreover, this activity requires high precision while positioning brackets and the modules, and for that reason, intensive survey and marking is necessary. In order to avoid such inconveniences, there have been experiences for the installation of façade modules in an automatic mode by using robotic devices. Within the HEPHAESTUS research project, a novel system has been developed in order to install CWMs automatically. The system consists of two sub-systems: a cable driven robot (CDPR) and a set of robotic tools named as Modular End Effector (MEE). The platform of the CDPR hosts the MEE. This MEE performs the necessary tasks for installing the curtain wall modules. There are two main tasks that the CDPR and the MEE need to achieve. First the fixation of the brackets onto the concrete slab. Second, the picking and placing of the CWMs onto the brackets. The first integration of the aforementioned system was carried out in a controlled environment that resembled a building structure. The results of this first test show that there are minor deviations while positioning the CDPR platform. In future steps, this deviations will be compensated by the tools of the MEE and the installation of the CWM will be carried out with the required accuracy and automatically.

**Keywords** –automation, on-site, robotics, facade

## 1 Introduction

The European construction sector constitutes an immense market. It is one of the main industrial employers in the European Union, contributing around 9% of its GDP, having an annual turnover of more than €1.500.000 million and a direct workforce of 18 million people [1]. Despite the fact that the construction sector is a fairly traditional sector, trends such as Smart Construction, involving advanced materials, innovative processes and concepts and green approaches, are becoming more noticeable.

The CWM is the building envelope technological system which represents the boundary condition between indoor and outdoor environment with the goal to guarantee and preserve the designed building performances. At this aim, the as-built façade needs to guarantee the correct installation of the CWMs to achieve the performances assessed by project specs, detailed in the design phase, and validated with tests conducted under EN 13830. This critical, but fundamental moment of installation phase requests a full accomplishment of operative instructions to guarantee the performances achievement with a strict accuracy of its components installation. Indeed, the CWM setting out is a millimetric activity due to the absolute position of façade so that the installation process and regulation guarantee that the as-built façade corresponds to the design. At this purpose, even if some mechanical regulations are possible through specific façade's components (bolts, screws, anchors), installers have today a central role. Additional to the installation operations to guarantee the correct setting out of the CWM in line with project specs, other relevant issues are related to site activities needed to manage risks and direct to preserve the safety of personnel involved

and of the correct maintenance of the equipment used. The safety of personnel involved in all site activities (not only the one responsible for façade) is the most relevant aspect. The safety procedures are independent of specific building components, but referred to general principles to be pursued for each activity during site operations dependent on national and local norms. In this frame, façade and its risk (e.g. lifting materials, equipment placement, exclusion zones, falling restraint for personnel and material, weather condition during lifting operations) are some of the risks to be considered during CWM installation to preserve the safety operation of the site activities. Within the scenario, to pursue the quality of installation while reduce its risk to preserve the site personnel safety, the automation through robot is an opportunity to be deeply investigated.

In order to cope with these issues, different robots for installing, painting, cleaning, delaminating, maintaining and inspecting any kind of facades were developed in the past. More specifically, several robotic devices have been classified for façade module installation [2]. Besides these single task robots, the so called on-site factories like ABCS [3] and SMART [4, 5] developed techniques for installing fully prefabricated façade modules on the erection of new buildings. Apart from façade modules, there have been experiences in on-site assembly of walls like in the Rocco project, in this case, for assembling building blocks [6]. Lee et al [7] developed a robot on top of a platform that helps the human operator to handle a curtain wall module. The most recent experiences of an installation of a façade module with a robot dates to a manually operated robotic crane [8]. Test results show that the worst case achieved repeatability of handler end-effector positioning is 7.0 mm. This result might not be sufficient for the installation of CWM. Regarding the cable robots for installing façade elements, a tendon suspended platform robot was envisioned [9], but the definition degree of that solution didn't show further detail, especially regarding the necessary cranes to support the loads and the forces of the cables. Moreover, that solution didn't show any type of on-board tools.

The principle of cable-driven parallel robots (CDPR) is to drive a mobile element in up to 6 degrees of freedom (DOF) by attaching cables to the mobile element and by synchronously controlling their length from a base frame. At least 6 cables are required for controlling all 6 DOFs of the load, while often more than 8 cables are used for better performance. The most well-known example of such robots are aerial cameras for stadiums [10] working with 3 DOF and 4 cables, and the first concept for manipulating all DOFs of a load dates back from the 1990s [11]. Cable-driven parallel robots are a subclass of parallel robots [12]. Instead of rigid links, they use cables to manipulate a mobile platform. The cables are actuated by winches. Today, they have already proven their

interest, in particular for large scale industrial applications [13, 14, 15]; indeed, the principle of a CDPR can be adapted to move heavy payloads over large dimensions. For these same reasons, CDPRs have being theorized in the past for several construction applications, from manipulation of elements to contour crafting and building inspection [9, 16].

For the HEPHAESTUS machine a redundantly constrained cable robot has been built. The redundancy of using eight cables to control the six degrees of freedom of the platform increases the available workspace volume. Only few related works involving cable robots in the field of construction can be found. In [17], a concept for a cable robot for large-scale assembly of solar power plants is introduced. In [18], a cable robot concept for a contour crafting system is described. In [19, 20], cable-robots for automated brick laying can be found.

The work performed in the frame of the HEPHAESTUS project [21] features the first time a CDPR is designed, built and deployed specifically for the construction sector, with the principal purpose of installing CWM, which encompasses two main tasks: bracket installation and module installation. The advantages of cable robots regarding the HEPHAESTUS machine are their large workspace, high payloads, re-configurability and modular components, which make it easily transportable.

## 2 Concept description

The aforementioned tasks (bracket installation and module placement) require high relative and absolute accuracy. For accomplishing such accuracy, it is necessary to foresee the precision of the CDPR, which it was estimated to have a tolerance of 40 mm [22] in previous phases. Therefore, in previous stages of the project, it was foreseen that there would be two means for installing the CWM: the CDPR for the rough positioning and the Modular End Effector (MEE) and its tools for the fine positioning.

### 2.1 CDPR

From a geometrical point of view, a CDPR is an association of cables of variable lengths linking a *drawing point*, attached to base frame, and a *fixing point*, attached to the mobile element or platform. How these drawing and fixing points are positioned in space, respectively in the general frame and the mobile platform frame, and how they are connected together build a *configuration*.

#### 2.1.1 CDPR calculation

The geometrical design of the CDPR presented in Figure 1 may be summarized as the definition of the following parameters: (i) number of cables, (ii) geometry of the structure, (iii) geometry of the platform and (iv)

cable configuration. Based on previous studies indicating that CDPRs driven by eight cables have appropriate performances [23] this number of cables was chosen. The parameters (ii) and (iii) are defined by the positions of the drawing points and attachment points, respectively (see Figure 1). The cable configuration (iv) defines the pairs of drawing and attachment points that are connected by cables. Therefore, significant efforts in the design of this CDPR were dedicated to the definition of an appropriate set of parameters (ii), (iii) and (iv).



Figure 1: Hephaestus CDPR prototype.

The abstract goal of finding an *appropriate* set of parameters has been formulated as an optimization problem. The cost function of the proposed optimization problem is the maximal cable tension, directly linked to the Safe Working Load (SWL), obtained during operation across the building facade. The choice of this cost function is motivated by direct relationship between the SWL and the cost of the machine. Minimizing the SWL leads to minimize the maximal loads that are applied on the mechanical parts of the CDPR and, therefore, minimize the cost. In addition, the constraints of the optimization problem includes the positioning accuracy which should meet the precision necessary to the installation of the curtain wall modules. Further details on the geometrical optimization of the Hephaestus CDPR prototype can be found in [24].

### 2.1.2 CDPR hardware

The Hephaestus CDPR is composed of 7 subassemblies. The first set of subassemblies provides the means of controlling the lengths of the cables. These subassemblies are fixed to the building, that works as the

base frame for the robot. They are called drawing point assemblies (DPA) and come in two types. The first type is fixed at ground level, materializing the lower drawing points of the proposed configuration (one per assembly). The second type is attached to the building top slab; each top DPA materialize two among the top drawing points. There are therefore 2 top DPAs and 4 bottom DPAs (Figure 2).



Figure 2: Left: top DPA. Right: bottom DPA.

Each drawing point need a winch, a swivel pulley at the location of the drawing point and a force sensor for monitoring cable tension. The components are the same for all drawing points. The travelling sheave winches (The VICINAY winches WB21.L30S.1, of SWL 15.7 kN, drum torque 2128 Nm, velocity 30 m/min, cable travel 16m, see Figure 3) are powered by a servomotor, with brake and absolute multi-turn encoder integrated with a gearbox and wire rope spooling synchronized with the grooved drum..

The swivel pulley installed at the theoretical location of the drawing point rotates about a vertical axis; it guides the cable towards the matching fixing point. The force sensor is embedded in the shaft of the sheave directing the cable from the winch to the swivel pulley. The steel wire rope is a  $\varnothing 11$  mm non rotating cable with a minimum breaking load of 115.5 kN.

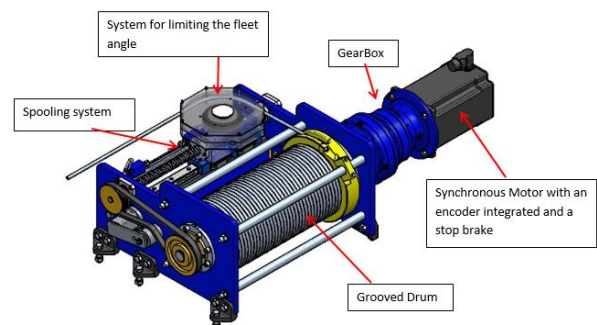

Figure 3: CAD view of the VICINAY Winch WB21.L.30S.1

The mechanical structure of the DPAs has been designed in order to transfer the load from the swivel



pulleys and the winches to the anchoring elements. They have been designed to show a displacement of less than 50 mm at the drawing point location under the safe working load.

Another CDPR subassembly is the mobile platform (Figure 1 and Figure 6). It features the 8 fixing points placed accordingly to the dimensions set in the configuration, as well as the various tools and power systems for the MEE. The total weight of the fully loaded platform reaches 1460 kg; 350 kg accounts for the carried CWM.

The norms applied during the design are ISO 4301, ISO 16625 and FEM 1.001. The as-built safe working load of the CDPR winches and components has been determined at 15.7 kN: all elements have been designed with a safety factor of at least 5.6 in order to match the M5 mechanism group requirements.

The final CDPR subassembly is a weatherproof electrical cabinet housing the central control unit. It features the servomotor drives, the associated power units, the central PLC, where the central control is implemented, and the associated inputs and outputs acquisition system. The cables towards the platform (data and power) are directed to it by the means of a cable chain mechanism fixed to a beam installed between the two top DPAs.

## 2.2 MEE and its components

The MEE is the set of tools that performs each of the activities that are necessary for installing the CWM onto the structure of the building. The MEE is fixed to the CDPR platform (see Figure 6). In the case of the HEPHAESTUS project two main activities need to be performed. First, there is the fixation of the bracket onto the concrete slab. This task is achieved by a robotic arm. Second, there is the placement of the CWM modules onto the brackets. This task is achieved by a vacuum system attached to the CDPR platform that picks CWM from an inclined magazine and releases the CWM when it is placed onto the brackets.

### 2.2.1 Robotic arm and its tools

A selection of tools need to be manipulated by the robot in order to mount brackets to hold the CWM to the building. The most versatile method is in-situ mounting and this was the chosen approach in this project. The list of actions needed to be handled by the robot is concluded: Drilling of holes for anchor bolts, picking and placement of bracket over holes, picking and placement of anchor bolts in holes, setting of bolts into holes, tightening of nuts of anchor bolts to set torque. A Universal Robots UR10e was selected as the tool manipulator. This was done based on previous experience with this robot and its possibilities and limitations, specifically regarding drilling in concrete. The robot arm also allows for excellent adaptability to changes based on underway

project learnings. The arm was mounted on a structure made for the occasion of profiled aluminum bars. A tool-changer system was integrated to give the robot arm the possibility to manipulate a variety of tools.

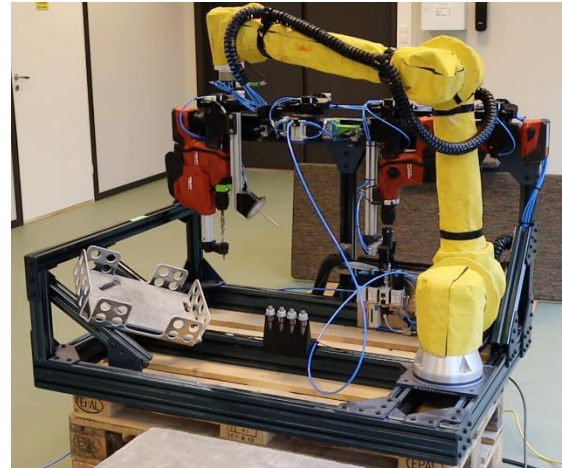

Figure 4: Robotic arm and its tools before mounting on the CDPR platform.

Four tools were put together to achieve the customized functionality needed: 1) the drilling tool, 2) the bracket picker and holder, 3) the setting tool with a hammer function and 4) a tool to torque the nut of the anchor.

The cycle is completed by the robot arm returning to the bracket holder and releasing the vacuum and magnets from the slab and bracket correspondingly before also the bracket holder is returned to the tool dock.

### 2.2.2 Stabilizer of the robot's frame

One of the issues regarding the accuracy of the robotic arm relied on the stability of the frame that hosts the robotic arm and its tools while performing tasks.

For achieving such needs, a linear system that included vacuum cups was defined, tested and prototyped. This linear system was conceived for hosting forces of up to 1500 N.

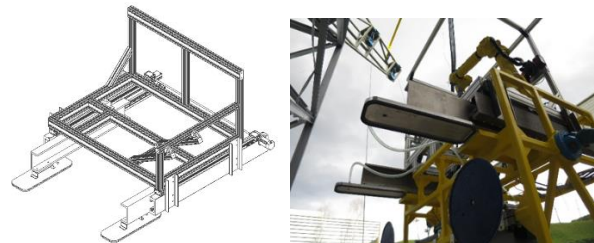

Figure 5: Stabilizer of the robot's frame. Left: CAD. Right: real prototype during the opening of the stabilizers.

The linear system consisted on two subsystems: the linear actuators and the machined steel profiles (see Figure 5) that run along rails with the help of carriers.

### 2.2.3 Vacuum Lifting System for picking and placing the CWM

The Vacuum Lifting System (VLS) is capable for picking and placing the CWM of 380 kg during operations that require inclined plans.

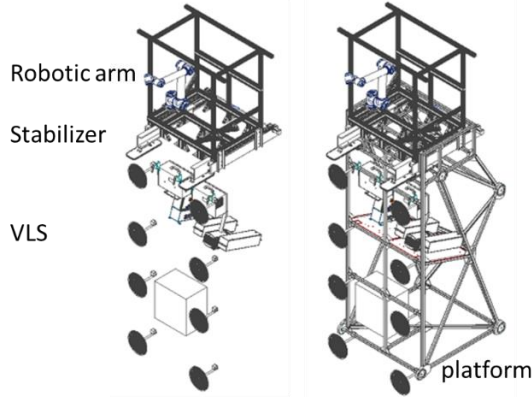

Figure 6: CAD showing the location of the MEE on the platform.

The VLS is designed to grip, in vertical position, a CWM with a smooth glass surface, the aforementioned mass, with a surface of 5.1 m<sup>2</sup>. It would be possible to work in both dry and wet states, but no ice, being friction coefficient 0.5 and 0.2 respectively. There are some site conditions that should be fulfilled: the altitude should be 900m from sea level up, the temperature between -5 to 40 °C, and the wind pressure during service  $q_v=125\text{N/m}^2$ .

The VLS is dimensioned to lift a load greater than or equal to twice  $[\gamma_f]$  its SWL with the minimum relative vacuum pressure  $q_r$ . The system makes a grip force ( $F_g$ ) between the surfaces of the CWM and those of the eight suction cups, which have a diameter  $\varnothing$  360mm each.

The total load solicitation vector ( $S$ ) is the sum of: the CWM masses ( $m_L$ ) multiply by gravity ( $g$ ), the inertial forces due to the movement plus those due to the action of the wind ( $F_w$ ), factorized each one with the applicable partial safety coefficients  $[\gamma_p]$ , are expressed as follows:

$$F_g = n \frac{\pi \cdot d^2 \cdot q_r}{4} \quad (1)$$

$$F_w = c_a \cdot q_v A \quad (2)$$

$$S = \left( \frac{m(g + j)}{\mu \cdot (1 \ 1 \ 1)^T} + \frac{\gamma_p \cdot F_w}{(\mu \ 1 \ \mu)T} \right) \quad (3)$$

The VLS, its warnings, and safety measures are connected to the Beckhoff control and therefore it can be activated automatically as explained in the next chapter

## 2.3 Control system

In Figure 7, the scheme of the hardware and wiring of the HEPHAESTUS machine is shown. The system consists of 4 PCs in total. Starting from the left side in the scheme, a standard PC is used to execute a software tool to automate the façade panel installation. This tool commands the steps in the correct order to mount the façade modules. Furthermore, it provides a GUI for the operator to control the whole HEPHAESTUS machine. It is connected to a total station via TCP/IP, which can measure the absolute pose of the cable robot platform and to the IPC on which the cable robot controller is running. The cable robot controller is based on the TwinCAT 3 software from BECKHOFF [25]. It consists of a soft-PLC and a motion controller. The latter can either be a Beckhoff CNC, or an advanced motion controller. The IPC is connected via WLAN (CANopen) to the Radio Control, via Ethernet (EtherCAT) to the safety sensors, I/Os, force sensors and drives. The IPC is connected via WLAN (CANopen) to the Radio Control, via Ethernet (EtherCAT) to the safety sensors, I/Os, force sensors and drives.

Furthermore, the IPC has an Ethernet (EtherCAT) interface to the IPC of the MEE, which is integrated within the EtherCAT network as an EtherCAT slave. On the MEE IPC a PLC is implemented to control the MEE system consisting of the ROS-PC to control the UR-Robot, the stabilizer, and the vacuum system.

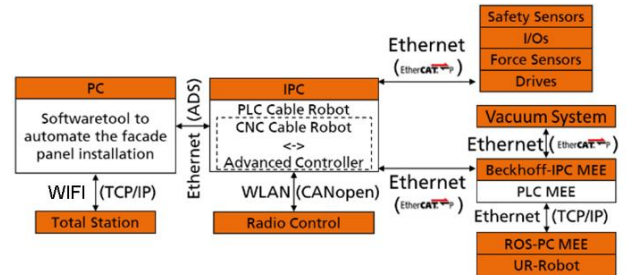

Figure 7: Scheme of the hardware and wiring of the HEPHAESTUS cable robot.

The main application controls the interactions between the user and the main controller. The application UI shows cable robot data, such as cable tensions, and each state the robot is performing in real time. It also allows the user to intercept in each state, pausing the operation, or to stop the task. It is connected to the cable robot controller, allowing the user to move the cable robot and see the state the cable robot and the MEE are in at any moment, allowing the user to operate and control it, and the total station controller, allowing to get position and rotation measures at will.

## 2.4 State Machine

The main controller is designed to operate as a state machine that controls all the individual controllers.

Likewise, it is designed to work separately from the UI, merging the real time environment with the UI thread, and it controls all the error controllers to broadcast individual error signals. There are two main operations that the robot must do in order to complete the curtain wall module installation successfully: First drill and set the brackets in the correct positions, and the set the curtain wall modules in the corresponding brackets. To do both of them there are several states that the controller must follow, each one of them linked to a specific controller (cable robot control, MEE control or total station control). Each state, as shown in the simplified state machine diagram of the picture, has an optional breakpoint where the user can stop the operation if a malfunction is detected. Besides these two main operations, the state machine contains also the semi-automatic initialization states of the total station.

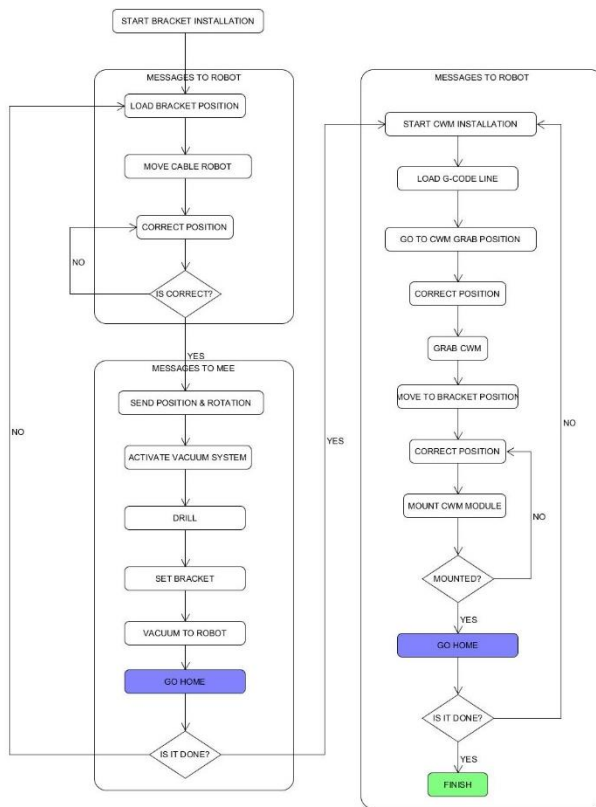

Figure 8: State machine simplified diagram

### 3 Prototyping and tests

The first demonstration tests were performed in TECNALIA facilities in Derio, Basque Country (Spain). Once all the components of the demonstrator were installed, the operation of all the components (engines, movement of the robot, positioning in relation with the steel structure, sensor, etc.) was verified. This was the

first time the different elements of the robot (winches with cable pulling on the platform/base) and the higher-level control of the robots that make the coordination of the winches were put together.

#### 3.1 Building structure used for the demonstration

For this purpose, a steel structure has been erected matching the foreseen dimensions of the demonstration building: 10.2m high by 8.80m wide and 2.7m deep. Two concrete slabs have been installed at the first and second floor to perform all tests required for installing one CWM. The steel structure has features to accommodate the top DPAs on the top floor; the bottom DPAs will be directly anchored to the ground (Figure 1)

The higher platform empty weight more than expected and the lower SWL than originally planned (respectively 1110 kg instead of 910 and 15.7 kN instead of 20) led to the nominal transit positions of the top row of panels not being accessible. The transit distance for top floor panels therefore needed to be reduced from 600 to 450 mm.

#### 3.2 Installation of the CDPR

After erection of the building, the DPAs, mobile platform and control cabinet are brought to the building site. The top DPAs (2500 kg each) have been installed on the building top floor by the means of a mobile crane. The bottom DPAs (1100kg each) can be moved around using a forklift. Once the DPAs have been installed, calibration must be carried out.

Calibration of the drawing point positions is performed thanks to the integration of total station targets onto the swivel pulley assemblies. Each swivel pulley assembly features 4 targets; their positions are used to build a local frame to reconstruct the current position of the associated drawing point. In order to calibrate the full system, apart from the A and B points, there are 3 Leica 360° [26] attached to the cable robot in order to track it on the move, 3 Leica 20x20 mm reflectors attached to the cable robot in order to calibrate the origin point of the MEE with respect to the cable robot and at least 3 Leica 20x20 mm reflectors to triangulate the building from the total station. It is highly advisable to calibrate all the prism and reflectors at once to get the maximum possible accuracy.

The calibration procedure has been performed at the same time as the installation of the DPAs, with the drawing point positions being monitored continuously by a surveyor with a total station. The objective was to have the DPAs installed as close as possible to their theoretical positions: the distance to the theoretical positions has been measured at maximum 19 mm.



### 3.3 Results

The first results of the demonstration shows a better performance than expected in previous phases of the research project. The maximum position error is around 2 cm and the max orientation error in around 0.8°. Moreover, the CDPR achieved high repeatability capabilities while moving the platform within the workspace. The deviations in respect to the desired position were supposed to be adjusted by the MEE while fixing the brackets. However, due to time constrains during the installation of the CDPR and the MEE, some calibration issues appeared and the transformed of the MEE in regards with the 0,0,0 point of the building was not achieved properly. For that reason, some deviations occurred during the placement of the bracket. This is a topic that will be improved on the next phase.



Figure 9: the MEE and the CDPR operating as shown in [21].

## 4 Conclusions and future work

The first test of a CDPR for installing CWM modules was achieved with better results than expected. However, there are still some points that need to be improved:

- Improve the calibration of the MEE in regards with the building in order to achieve a better accuracy.
- The recognition of the CMW while it stands on the magazine and know the location of it in order to adjust deviations.
- Recognition of the brackets that are already fixed on the building slab in order to adjust, if necessary, the CDPR path while placing the CWM.

In order to seek for future commercialization, a market research was carried out which found a growing awareness from building owners and residents about comfort and health, political and economic drivers (e.g: nZEB and other EU directives, incentive schemes and favorable tax regimes, especially for green construction). Technological innovations will complete these drives, making investors, policymakers and professionals (i.e. architects, designers as well as façade manufacturers) to accelerate adoption of construction robots. Therefore, the goal is that in the coming years the innovations mentioned in this paper will reach the market as exploitable results for the: i) CDPR for vertical works:

suitable for handling, moving and placing curtain wall modules: ii) MEE: including several tools to automate the insertion of a connector onto the building's structure; iii) Curtain wall adapted to robotic installation: for fixing elements of the curtain wall module (CWM) to slab; CWM to bracket; and connection between CWMs; and Hephaestus Cable Robot entire system: as an integrated solution for handling and installing curtain wall modules. To facilitate commercialization of new device categories, standards can do the following:

1. Standardize the components and interfaces from which it is made up in order to allow for faster development and efficient supply chains ("interoperability")
2. Standardize the processes and infrastructures which surround the new technology or product/service
3. Ensure quality and efficiency of the technology and/or its development processes in order to minimize the risk for the involved stakeholders

During a final demonstration stage of the project, the robot will be required to complete the installation of a set of curtain wall modules covering part of the façade of a DEMO building specifically built and enabled for these activities. This DEMO building has been erected in the machinery park owned by ACCIONA and located in Noblejas, Toledo (Spain), so the performance of the cable robot could be demonstrated in a real construction environment. The DEMO building has been erected with three floors and a total height of 10.20 meters, and the façade is 8.5m wide. To access the various floors of the DEMO building during demonstration activities, a staircase has been installed on the back side of the building where no facade panels will be installed. The cable robot will be validated, among other performance indicators, in terms of time required to complete the operations for the curtain wall module placing, the accuracy, the efficiency and the usability for workers of the construction sector. Also, special care will be taken in order to fulfil the safety requirements and recommendations for these robotic operations.

## Acknowledgements



*This project has received funding from the European Union's Horizon 2020 research and innovation programme under grant agreement No 732513.*

## References

- [1] E. Commission, "Construction. Internal Market, Industry, Entrepreneurship and SMEs," [Online]. Available: [https://ec.europa.eu/growth/sectors/construction\\_en](https://ec.europa.eu/growth/sectors/construction_en). [Accessed 10 June 2020].



- [2] T. Bock and K. Iturralde, "Automated and Robotic Process Lifecycle of Prefabricated Facades," in *Neue Entwicklungen im Betonbau*, Beuth Verlag GmnH, 2019, pp. 117-129.
- [3] Obayashi-Corporation, Director, *ABCS Riverside Sumida Bachelor Dormitory Documentary Video*. [Film]. 1993.
- [4] H. Miyakawa, J. Ochiai, K. Oohata and T. Shiokawa, "Application of automated building construction system for high rise office building," in *Proceedings of 17th International Symposium on Automation and Robotics in Construction*, Taipei, Taiwan, 2000.
- [5] J. Maeda, "Development and Application of the SMART System," in *Automation and Robotics in Construction*, Elsevier Science B.V., 1994, pp. 457-464.
- [6] E. Gambao, C. Balaguer, A. Barrientos, R. Saltaren and E. Puente, "Robot assembly system for the construction process automation," in *Proceedings of International Conference on Robotics and Automation*, Albuquerque, USA, 1997.
- [7] S. Y. Lee, M. Gil, K. Lee, S. Lee and C. Han, "Design of a ceiling glass installation robot," in *Proceedings of 24th International Symposium on Automation and Robotics in Construction*, Madras, 2007.
- [8] J. Činkelj, R. Kamnik, P. Čepon, M. Mihelj and M. Munih, "Closed-loop control of hydraulic telescopic handler.," *Automation in Construction*, 19(7), pp. 954-963., 2010.
- [9] C. Thompson and P. J. Campbell, "Tendon suspended platform robot". U.S. Patent Patent 5,585,707, 17 December 1996.
- [10] L. Cone, "Skycam - an aerial robotic camera system.," *Byte*, vol. 10, no. 10, pp. 122-132, 1985.
- [11] J. Albus, R. Bostelman and N. Dagalakakis, "The NIST Robocrane," *Journal of Robotic Systems*, vol. 10, no. 5, pp. 702-724, 1993.
- [12] A. Pott, *Cable-driven parallel robots: theory and application*, Springer, 2018.
- [13] M. Gouttefarde, J.-F. Collard, N. Riehl and C. Baradat, "Geometry selection of a redundantly actuated cable-suspended parallel robot," *IEEE Transactions on Robotics*, vol. 31, no. 2, pp. 501-510, 2015.
- [14] A. Pott, H. Mütterich, W. Kraus, V. Schmidt, P. Miermeister and A. Verl, "IPAnema: A family of Cable-Driven Parallel Robots for Industrial Applications," *Cable-Driven Parallel Robots*, 2013.
- [15] D. Culla, J. Gorrotxategi, M. Rodríguez, J.-B. Izard and P.-E. Hervé, "Full Production Plant Automation in Industry Using Cable Robotics with High Load Capacities and Position Accuracy," *Iberian Robotics conference*, pp. 3-14, 2017.
- [16] J.-B. Izard, M. Gouttefarde, C. Baradat, D. Culla and D. Sallé, "Integration of a parallel cable-driven robot on an existing building façade," *Cable-Driven Parallel Robots*, pp. 149-164, 2013.
- [17] A. Pott, C. Meyer and V. A., "Large-scale assembly of solar power plants with parallel cable robots," in *(41st International Symposium on Robotics) and ROBOTIK 2010 (6th German Conference on Robotics) VDE*, 2010.
- [18] P. Bosscher, R. L. Williams II, L. S. Bryson and D. Castro-Lacouture, "Cable-suspended robotic contour crafting system," *Automation in Construction*, pp. 45-55, 2007.
- [19] I. Vukorep, "Autonomous big-scale additive manufacturing using cable-driven robots," in *Proceedings of the International Symposium on Automation and Robotics in Construction*, Taiwan, 2017.
- [20] T. Bruckmann, C. Reichert, M. Meik, P. Lemmen, A. Spengler, H. Mattern and M. König, "Concept Studies of Automated Construction Using Cable-Driven Parallel Robots," *Cable-Driven Parallel Robots. Springer, Cham*, pp. 364-375, 2018.
- [21] R2M Solutions, "Hephaestus - EU H2020 Project," 2017. [Online]. Available: <http://www.hephaestus-project.eu/>.
- [22] M. Taghavi, K. Iturralde and T. Bock, "Cable-driven parallel robot for curtain wall modules automatic installation," in *35th International Symposium on Automation and Robotics in Construction*, Berlin, 2018.
- [23] M. Gouttefarde, J. Lamaury, C. Reichert and T. Bruckmann, "A Versatile Tension Distribution Algorithm for n-DOF Parallel Robots Driven by n + 2 Cables," *IEEE Trans. Robot.*, vol. 31, no. 6, p. 1444-1457, 2015.
- [24] H. Hussein, J. C. Santos and M. Gouttefarde, "Geometric Optimization of a Large Scale CDPR Operating on a Building Facade," in *IEEE International Conference on Intelligent Robots and Systems*, 2018.
- [25] Beckhoff. [Online]. Available: <https://www.beckhoff.de/default.asp?twincat/twincat-3.htm>. [Accessed 09 June 2020].
- [26] Leica. [Online]. Available: (<http://www.surveyequipment.com/PDFs/leica-white-paper-surveying-prisms.pdf>) . [Accessed 09 June 2020].